

# THE RADIO EXPERIMENTER'S MAGAZINE

HUGO GERNSBACK  
Editor

# SHORT WAVE CRAFT

August

WORLD'S  
LARGEST  
SHORT WAVE  
CIRCULATION

Combined  
With

OFFICIAL  
**Short Wave  
Listener**  
MAGAZINE

Short Wave  
**RADIO BOMB**  
Locates Mineral Deposits  
See Page 200



25¢

The Whole Family Will Thrill to the Glorious Reception of this **NEW 1937 AIR-TESTED MIDWEST**

Only **MIDWEST** gives you **16 TUBES...5 WAVE BANDS...**  
**9 to 2200 METERS...ELECTRIK SAVER...PUSH BUTTON TUNING...**  
**AUTOMATIC AERIAL ADAPTION...DUAL AUDIO PROGRAM EXPANDER**

and Scores of Other Features for only

**\$49.95** COMPLETE WITH GIANT THEATRE-SONIC SPEAKER  
 (LESS TUBES)



**30 DAYS Free TRIAL!**

**TERMS AS LOW AS 10¢ PER DAY**

**SAVE UP TO 50% BY BUYING DIRECT FROM MIDWEST FACTORY**

ONCE again, Midwest demonstrates its leadership by offering the world's most powerful ALL-WAVE 16-Tube, 5-Band Radio. A startling achievement, it makes the whole world your playground. Powerful Triple-Twin tubes (two tubes in one!) give 18-tube results! It is a master achievement, a highly perfected, precisely built, radio-musical instrument that will thrill you with its marvelous super performance . . . glorious crystal-clear "concert" realism . . . and magnificent foreign reception. Before you buy, write for the FREE 40-page 1937 catalog. Never before so much radio for so little money. Why pay more?

No middlemen's profits to pay! Buying direct from the Midwest factory makes your radio dollar go twice as far. See for yourself that Midwest offers you greater radio value—enables you to buy the more economical factory-to-you way that thousands of radio purchasers have preferred since 1920.

You can order your Midwest 1937 radio from the new 40-page catalog with as much certainty of satisfaction as if you were to come yourself, to our great factory. (It pictures the beautiful 1937 Radios . . . in their actual colors!) You save 30% to 50%—you get 30 days free trial—and you pay as little as 10c a day. Satisfaction guaranteed or money back. Write today for FREE catalog.

**85 ADVANCED 1937 FEATURES**

This Super DeLuxe Midwest is so powerful, so amazingly selective, so delicately sensitive that it brings in distant foreign stations with full loud speaker volume on channels adjacent to powerful locals. Scores of marvelous Midwest features, many of them exclusive, make it easy to parade the nations of the world before you. You can switch instantly from American programs . . . to Canadian, police, amateur, commercial, airplane and ship broadcasts . . . to the finest and most fascinating foreign programs.

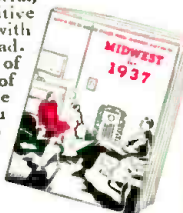

I AM TREMENDOUSLY IMPRESSED WITH THE REMARKABLE PERFORMANCE OF MY MIDWEST . . . .  
*Robert Montgomery*



MUSICIANS EVERYWHERE COMMENT ON THIS . . . . REMARKABLE INSTRUMENT  
*Johnny Green*

**Electrik-Saver Reduces Wattage Consumption 50%**  
 The magical exclusive Electrik-Saver enables Midwest radios to operate on low line voltage—as low as 80 volts! . . . and explains why they consume no more current than ordinary 7-tube sets. It is a real inser begrudging every penny's worth of current that flows through the meter.



**MIDWEST RADIO CORP.**

DEPT. B-14, CINCINNATI, OHIO, U.S.A.  
 Established 1920 Cable Address MIRACO...All Codes

**MAIL COUPON TODAY for Free 30-DAY TRIAL OFFER and 40-PAGE FOUR-COLOR Free CATALOG**

MIDWEST RADIO CORPORATION  
 Dept. B-14, Cincinnati, Ohio

Without obligation on my part, send me your new FREE catalog and complete details of your liberal 30-day FREE trial offer. This is NOT an order.

Special offer and prices prevail only when dealing direct with factory by mail.

Name \_\_\_\_\_  
 Address \_\_\_\_\_  
 Town \_\_\_\_\_ State \_\_\_\_\_

# OPPORTUNITIES *are many* for the Radio Trained Man

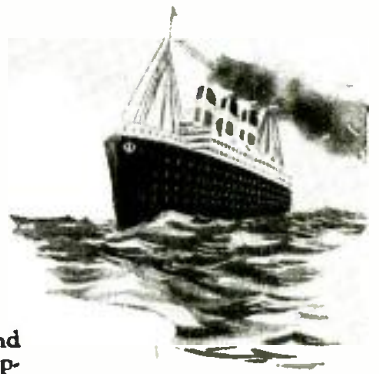
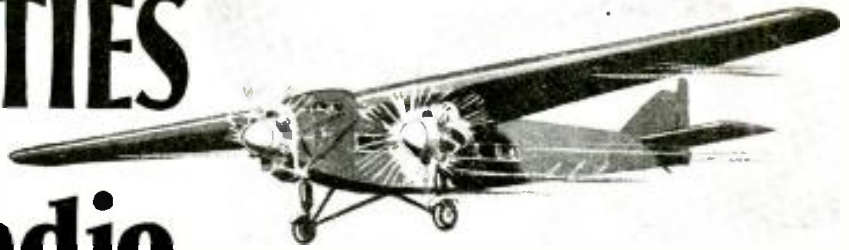

Don't be an untrained man. Let me show you how to get your start in Radio—the fastest growing, livest money-making game on earth.

## Jobs Leading to Salaries of \$35 a Week and Up

Prepare for jobs as Designer, Inspector and Tester—as Radio Salesman and in Service and Installation Work—or for work in a Broadcasting Station—as Wireless Operator on a Ship or Airplane, or in Talking Picture or Sound Work—HUNDREDS OF OPPORTUNITIES for a real future in Radio!

## Ten Weeks of Shop Training Pay Your Tuition After Graduation

We don't teach by book study. We train you on a great outlay of Radio, Television and Sound equipment—on scores of modern Radio Receivers, huge Broadcasting equipment, Television apparatus, Talking Picture and Sound Reproduction equipment, Code Practice equipment, etc. You don't need advanced education or previous experience. We give you—RIGHT HERE IN THE COYNE SHOPS—the actual practice and experience you'll need for your start in this great field. And because we cut out all useless theory and only give that which is necessary you get a practical training in 10 weeks.

# TELEVISION *and* TALKING PICTURES

And Television is already here! Soon there'll be a demand for THOUSANDS of TELEVISION EXPERTS! The man who learns Television now can have a great future in this great new field. Get in on the ground-floor of this amazing new Radio development! Come to COYNE and learn Television as it should be learned on Television equipment. Talking Picture and Public Address Systems offer opportunities to the Trained Radio Man. Here is a great new Radio field just beginning to grow! Prepare NOW for these wonderful opportunities! Learn Radio Sound Work at COYNE on actual Talking Picture and Sound Reproduction equipment.

## PAY FOR YOUR TRAINING After You Graduate

I am making an offer that no other school has dared to do. I mean exactly what I say. You can get a complete training by the world's oldest and largest Practical Radio School and I'll finance your Tuition. You won't have to start paying me back in small, monthly payments until 2 months after your required training period is over. I consider the fellow who is ambitious enough to want to get ahead by taking my Training, worthy of my help. MAIL THE COUPON BELOW, and you can prove to me that you are willing to spend just TEN WEEKS in the Coyne Training Shops Learning RADIO. Then, I'll tell you how I finance your Tuition—give you your complete Training and let you pay me back later.

I've got enough confidence in ambitious fellows and in my methods to give them the training they need and let them pay me back after they have completed their training.

### ELECTRIC REFRIGERATION AIR CONDITIONING

To assure your thorough preparation for a prosperous future, I include—at no extra cost—a course in Electric Refrigeration and Air Conditioning, taught you by personal instruction and actual work on latest-type equipment.

### ALL PRACTICAL WORK At COYNE in Chicago

ALL ACTUAL, PRACTICAL WORK. You build radio sets, install and service them. You actually operate great Broadcasting equipment. You construct Television Receiving Sets and actually transmit your own Television programs over our Television equip-

ment. You work on real Talking Picture machines and Sound equipment. You learn Wireless Operating on Actual Code Practice apparatus. We don't waste time on useless theory. We give you the practical training you'll need—in 10 short, pleasant weeks.

### MANY EARN WHILE LEARNING

You get Free Employment Service for Life. And don't let lack of money stop you—my plan makes it possible to get Coyne training with very little money. Many of our students make all or a good part of their living expenses while going to school and if you should need this help just write to me. Coyne is 36 years old. Coyne Training is tested—proved beyond all doubt. You can find out everything absolutely free. Just mail coupon for my big free book!

H. C. Lewis, Pres. RADIO DIVISION Founded 1899

## Coyne Electrical School

500 S. Paulina St., Dept. C6-2K, Chicago, Ill.

Mail Coupon Today for All the Facts

H. C. LEWIS, President

### Radio Division, Coyne Electrical School

500 S. Paulina St., Dept. C6-2K, Chicago, Ill.

Dear Mr. Lewis:—Send me your Big Free Radio Book, and all details of your Special Offer, including Electric Refrigeration, Air Conditioning courses and your "Pay After Graduation" offer.

Name \_\_\_\_\_

Address \_\_\_\_\_

City \_\_\_\_\_ State \_\_\_\_\_

**IN THIS ISSUE: PROMINENT SHORT-WAVE AUTHORS**

**Southworth • Schrage • Secor • Hooton • Cisin • Miles • Shuart • Palmer**



**HUGO GERNSBACK**  
Editor

**H. WINFIELD SECOR**  
Managing Editor

**GEORGE W. SHUART,**  
**W2AMN**  
Associate Editor

*Combined With*  
**Official SHORT WAVE LISTENER**

**Contents for August, 1936**

Editorial—"Television on Short Waves," by Hugo Gernsback .....	195
Short Waves in the Camera's Eye.....	196
Short Waves Directed HINDENBURG To America, by W. E. Schrage.....	197
Electric Wave Guides, by G. C. Southworth, Bell Telephone Laboratories .....	198
Short Waves and Long Raves—Our Readers Forum....	199
Short-Wave "Radio Bomb" Locates Mineral Deposits (Cover Feature), by W. E. Slope.....	200
Radio 100 Years Old!, by H. W. Secor.....	201
"Queen Mary" Uses 32 Different Wave-Lengths.....	202
Where S-W Stations Come In On YOUR Dial.....	202
High-Gain "Metal-2" Receiver for "Fan" or "Ham," by Harry D. Hooton, W8KPX.....	203
Midget "Metal-Tube" All-Wave 4, by H. G. Cisin, M.E.	204
How To Experiment With New Circuits, by Willard L. Miles .....	205
A "Sure-Fire" 5-Meter Super-Regenerator, by George W. Shuart, W2AMN.....	206
Ultra Short-Wave Super-Het—with Pre-Selection Stage, by C. W. Palmer.....	207
The "Beam Tube-3" an Astonishing Transmitter, by George W. Shuart, W2AMN.....	208
Improving the 2-Volt Superhet Receiver, by H. D. Hooton, W8KPX .....	210
All-Band Transmitting Doublet.....	211
A Strong, Easily-Made Hole-Cutter, by Henry Laraby	211
\$5.00 Prize for Best "Kink".....	212
World Short-Wave and Time-Zone Map.....	213
What's New In Short-Wave Apparatus—The Hammarlund "Super-Pro" Receiver.....	214
New Apparatus for the "Ham".....	217
Radio Amateur Course, Conducted by Geo. W. Shuart, W2AMN .....	218
A. F. Amplifier for 1 Million Cycles!.....	219
Short Wave League and Scout News.....	220
World S-W Station List, by M. Harvey Gernsback.....	221
Alphabetical List of S-W Stations.....	225
Short Wave Question Box.....	226
Short Wave Scouts—Twenty-Ninth Silver Trophy Award .....	228
When to Listen In.....	241



**Certified Circuits**

● **SHORT WAVE CRAFT** goes to a large expense in verifying new circuits. When you see this seal it is your guarantee that such sets have been tested in our laboratories, as well as privately, in different parts of the country. Only "Constructional-Experimental" circuits are certified by us.

When you see our certified seal on any set described, you need not hesitate to spend money for parts, because you are assured in advance that the set and circuit are bona fide and that this magazine stands behind them.

**SHORT WAVE CRAFT** is the only magazine that certifies circuits and sets.

**OUR COVER**

● The illustration on the cover this month shows the newest short-wave invention—the "Radio Bomb," which enables prospectors to determine what kind of mineral deposits are imbedded in the soil being surveyed. The instrument is illustrated and described on Page 200.

COPYRIGHT, 1936, BY H. GERNSBACK

**Published by POPULAR BOOK CORPORATION**

HUGO GERNSBACK, President - - - - H. W. SECOR, Vice-President  
EMIL GROSSMAN - - - - - Director of Advertising  
Chicago Adv. Office - - - - - L. F. McCLURE, 919 No. Michigan Ave.  
Publication Office - - - - - 404 N. Wesley Avenue, Mount Morris, Ill.  
Editorial and General Offices - - - - - 99-101 Hudson St., New York, N. Y.  
European Agent: Gorrings's American News Agency, 9A Green St., Leicester Square, London W. C. 2  
Australian Agents: MCGILL'S AGENCY, 179 Elizabeth St., Melbourne

**Features in the Sept. "Ham" Issue**

- A 5-Meter MOPA Transmitter, using two of the new 6L6 Beam tubes, by G. W. Shuart, W2AMN.
- A Compact 5-Meter Transmitter-Receiver using Metal tubes, by Henry B. Plant, W6DKZ.
- A new "Double" I. F. Superhet, by M. Harvey Gernsback. Something Really New!
- How to Make a "Bug" Key.
- 5-Meter Receiver of the Very Latest Type, by W2AMN.
- And plenty of "features" for the S.-W "Fan."

**SHORT WAVE CRAFT**—Monthly. Entered as second class matter May 7, 1930, at the post office at Mount Morris, Illinois, under the act of March 3, 1879. Trademarks and copyrights by permission of H. Gernsback, 99-101 Hudson St., N. Y. C. Text and illustrations of this magazine are copyrighted and must not be reproduced without permission. **SHORT WAVE CRAFT** is published on the 1st of every month. Twelve numbers per year. Subscription price is \$2.50 a year in the United States and possessions and Canada. Foreign countries, \$3.00 a year. Single copies 25c. Address all contributions for publication to Editor, **SHORT WAVE CRAFT**, 99-101 Hudson St., New York, N. Y. Publishers are not responsible for lost manuscripts. Contributions cannot be returned unless authors remit full postage. **SHORT WAVE CRAFT** is for sale at all principal newsstands in the United States and Canada. European agents: Brentano's, London and Paris. Printed in U. S. A. Make all subscription checks payable to Popular Book Corporation.



## Television On Short Waves

An Editorial by Hugo Gernsback

● WHILE television is still in the experimental stage and while it will be quite a while before it becomes actually available to the public at large, the indications are today that when we finally do have television, *short waves* will be used as a transmitting medium. At least, present indications point that way, for a number of technical reasons, and unless a totally unprecedented invention is made in the meanwhile, we are reasonably sure that television transmission will take place on wave lengths between five and ten meters.

The question is frequently asked by our readers just how the television impulses as well as the sound impulses will be transmitted. There is little doubt today that we will have to do with a simultaneous transmission, where sight and sound are both transmitted on the identical wave at the same instant. The original experiments, taking place some years ago, were all made on dual waves; that is, the television impulses were broadcast on one wave length, sound on another wave length. This meant that two channels had to be used, which not only made for cumbersome technical arrangement, but entirely too much space was taken up in the wave band, which alone tended to make television impractical. The use of a single frequency, where—by double modulation—sound as well as sight can be broadcast, offers no serious technical difficulties today. As a matter of fact, the pioneer work was done years ago by the Columbia Broadcasting System from their New York studios, and simultaneous broadcasting of sight and sound was even then an accomplished fact.

The transmission problem of television itself today may be said to be fairly well solved. It is, however, in the *receiving end* where the difficulty lies today. So far nothing worth while has been produced in television receivers that would make television immediately attractive to the public.

We still have to overcome many difficulties, chiefly among which are that the final word in television has not been spoken. We still have to contend with cumbersome, mechanical scanners, or cathode ray scanning apparatus. Both of these may be said to be impractical from the public standpoint, due to their exceedingly high cost. As long as television receivers sell anywhere from two hundred dollars upwards, *television has not arrived*, as far as the public is concerned! Nor are broadcasters likely to spend fortunes in erecting huge television broadcast stations and transmit enormously expensive television programs, if there are only a few scattered television receivers in the country.

Radio broadcasting is what it is today, simply because there are over *twenty million radio receivers in the country today*, not to speak of *several million car radios!* This huge number of radio sets in the homes of the public was made possible only due to a popular-priced receiver. It may be said, therefore, that if television receivers can be made and sold for about *twenty-five dollars* or thereabouts, then tele-

vision will have arrived, granting that other problems which have not as yet been solved, have been overcome.

I believe that the short-wave experimenter is in a particularly fortunate position, as far as television is concerned, because short waves as already mentioned are the instrumentality through which television finally will be broadcast. The short-wave experimenter and amateur, has the necessary technical knowledge of short waves; he knows its requirements; he knows its vagaries, and he is, as a rule, well versed in all short-wave intricacies. The short-wave experimenter and amateur, therefore, will be the logical man to help perfect television.

Years ago, before the broadcast radio boom, the radio experimenters and amateurs were in a like position. Most of the serious-minded boys of that day now hold various important positions in the radio industry. This was a logical evolution, and I am certain that history will repeat itself when television finally "breaks."

Of course, the great handicap at the present time is that there is not much to experiment with today. Cathode ray tubes are expensive, and mechanical scanners are not very popular. It therefore resolves itself down to the point where the serious and studious experimenter will have to be completely "on his own"; and perhaps this is just as well, because only in this manner will television finally be solved. If a thousand, bright short-wave experimenters and amateurs were to say to themselves that for one year they would become "television minded," and spend most of their time in experimenting *along new paths*, leaving the beaten track, I am sure that at the end of one year remarkable results would be achieved. After all, someone has to do the job, and it is not impossible that the solution will be made by some experimenter—perhaps you who are reading this.

Remember, all the great radio minds of the world were experimenters at one time. Marconi, De Forest, Fessenden, and a host of others started just as you have started, namely, by experimenting and by trying to overcome obstacles that others could not overcome. It should never be forgotten that the short-wave experimenter has the education, the knowledge, and the experience to pioneer in television.

And it is not always the exclusive and well-equipped laboratory that produces the best results. Take, for instance, the noted television researcher, Baird of London. Single-handed and without a high-priced laboratory to fall back upon, he tackled the problem in the face of fearful odds, and in spite of these, he obtained results and achieved a remarkable success in the early days of television, without having to spend fortunes. He merely believed in himself, and he was a good experimenter to boot!

Television offers tremendous opportunities simply because it is new and because, as yet, it has not been really exploited. And it is usually those that start in at the ground floor who reap the results.

---

**SHORT WAVE CRAFT IS PUBLISHED ON THE 1st OF EVERY MONTH**

This is the August, 1936 Issue—Vol. VII, No. 4. The Next Issue Comes Out August 1

---

Editorial and Advertising Offices, 99-101 Hudson Street, New York City

# Short Waves In The Camera's Eye

Left—New ultra short-wave machine for treating arthritis and rheumatism; shown in use at the Philadelphia County Medical Society's Post-Graduate Institute. The apparatus is being demonstrated for treatment of the knee.

Below—An exciting "Ham" radio incident from the fine motion picture—"The Country Doctor." "Ham" radio comes to the rescue of the Country Doctor when he is badly in need of serum, and thanks to the "Ham," the serum is sent by airplane just in the nick of time.



Above—New British Army radio equipment car known as the "Baby Car-Radio Station." A number of these short-wave mobile stations have been added to the British Army recently; they have quickly collapsible antenna masts.

Above—at right—two of Hollywood's charming young stars, Jean Chadburn and Eleanor Steward, who are demonstrating the latest idea for fishermen—a "combination radio-set and fishing outfit," which straps on the back in a light leather case. There are compartments for the fish-hooks and other fishing paraphernalia.

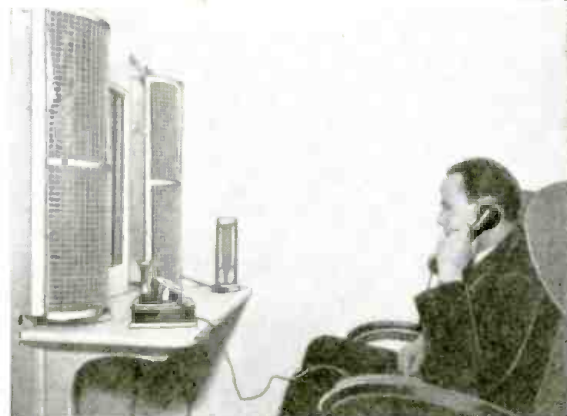

The latest television phone line recently opened between Berlin and Leipzig, Germany, a distance of about 125 miles. The photos directly above show the excellent television reproduction obtained over this 125 mile circuit. The telephone subscriber sits in front of a special image pick-up equipment. (Berlin booth at left), the subject being illuminated by invisible infra-red rays. The photo-electric cell used to pick up the reflected rays is sensitive to these infra red rays. The fluctuating currents corresponding to the variations in the rays reflected onto the photo-cell, are caused to actuate a cathode-ray tube at the receiver.



Fig. 2. This illustration shows the location of the two loop aerials just ahead of the control gondola and also the auxiliary antennas for the "direction finder" and the "blind landing" receivers.

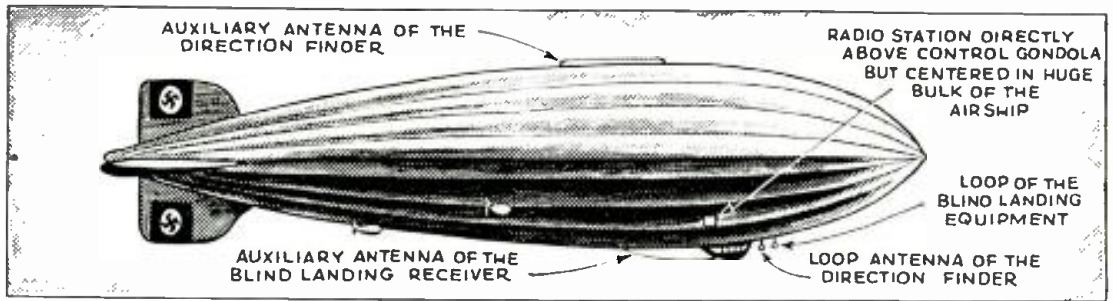

# Short Waves Directed To HINDENBURG America

An exclusive interview with the radio operators of the "HINDENBURG" for Short Wave Craft  
By W. E. Schrage

Short waves played a very important part in guiding the huge airship "Hindenburg" across the Atlantic. The airship was in constant touch with land as well as ship stations. A specially devised short-wave "blind landing" indicator was installed, as explained in detail in the accompanying article.

the importance of short-wave communication links in airship traffic, let's go back a little in airship history (as far as the application of radio equipment is concerned). Since the first Zeppelin (L.Z. 1) started on an experimental flight, July 2nd,

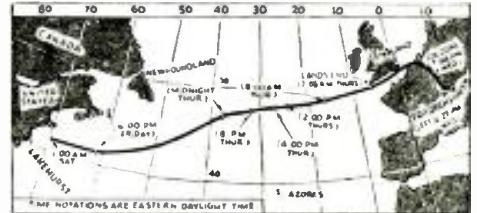

Fig. 1. Short-wave Weather and Position reports, together with the radio "direction finder" hearings, helped to guide the airship, "Hindenburg" to the United States.

1900, Germany has built 129 Zeppelins, and approximately 120 of them have been equipped with radio stations!

### First Zeppelin Transmitter

The first Zepp-radio-station had only a small 50 watt transmitter which was installed into a box about 4 x 4 x 5 feet in size. Everything except the antenna reeling device was enclosed in air-tight containers, because of the danger of explosion presented by the spark-gap generator of the transmitter. This transmitter operated on a wavelength of about 6,000 meters, which was considered at that time as the best wavelength for airships.

The experience with this antique Zepp-radio equipment led to the design of tube type transmitters, which operated on a "shorter" wavelength of about 3,000 meters. Following the trend of radio development, the wavelength became shorter and shorter, and the longwave transmitter of 200 watts output in the Hindenburg's radio equipment goes down in its wave range from 2,700 to 575 meters.

The growing importance of short waves for air-ship communication was learned when the author (through the courtesy of the (Continued on page 232)

● WHEN in the early part of May the new German airship *Hindenburg* (the L.Z. 129) crossed the Atlantic, mil-

equipment is concerned). Since the first Zeppelin (L.Z. 1) started on an experimental flight, July 2nd,

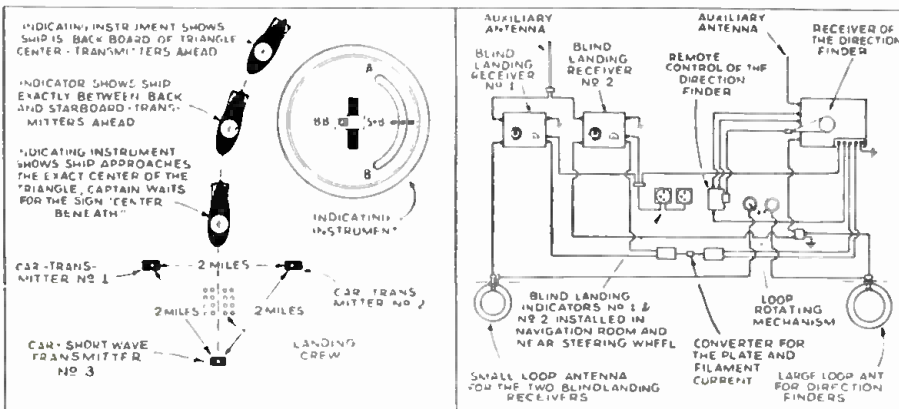
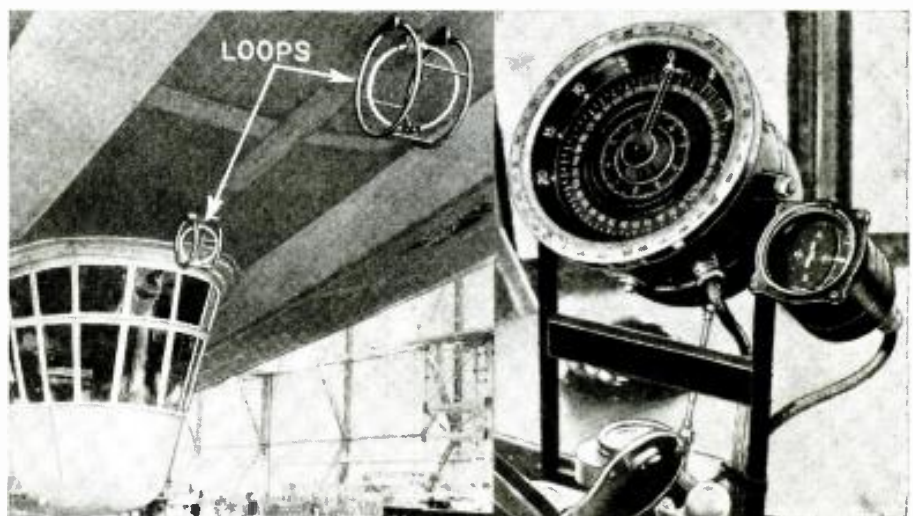

Fig. 1. How the "blind-landing" receivers and the "direction finder" receiver are operated in a bridge-type circuit, so that the "balanced" outputs of the 3 receivers enable the radio operator to obtain his exact location even in a fog. Fig. 3. Shows successive positions of the airship when it is brought into a landing with the aid of 3 ground transmitters; special instrument tells the pilot when the ship is directly over the triangle formed by the three ground units.

lions of American radio listeners witnessed via radio waves the majestic flight of this new giant of the air. However, only a few of them knew about the important role short waves played in this unique example of modern broadcast entertainment; and but few people possibly were aware of the fact that the splendid execution of this initial flight—which meant the beginning of a regular passenger and airmail service between America and Europe, was due in a great measure to the short-wave links applied during this historical flight.

There are few examples in modern radio development which demonstrate the importance of short-wave links in such a striking manner as the first flight of the L.Z. 129 to America; and it is not exaggeration to state that without the application of the short-wave-channels provided this flight would probably not have been as successful as it was.

To promote a better understanding of



Steering wheel of the Zeppelin with "blind landing" indicator, which helps to land the airship in case the airport is covered by fog. Loop antenna in front belongs to "blind landing" indicator; one near gondola is for "direction finder."

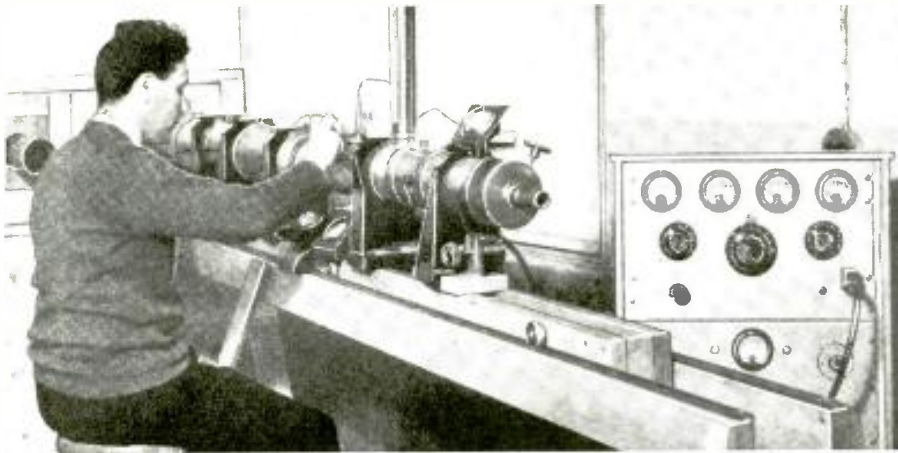

A. P. King at the sending end of the experimental wave-guide at Holmdel, N. J.

Strange things begin to happen in radio transmission lines, when we start experimenting with frequencies as high as 2,000 megacycles, as Mr. Southworth points out. Experiments disclosed the startling fact that when a concentric conductor was used with these ultra-high frequencies, not only the inner but the outer metal tube could be removed and transmission carried on along a rod of *insulating* material! The open end of a wave-guide may even be made to radiate power, similar to sound waves issuing from a pipe, by expanding the end of the guide into a cone shape, thus producing an "electrical horn!"

# Electric Wave Guides

• IN the early days of electrical communication, it seemed axiomatic that there must be a completed circuit to permit the flow of electric current or power. A return path, either in the form of another wire or the earth, was apparently essential. With the advent of radio this seemingly fundamental law was broken, because for radio transmission no return path in any ordinary sense is required. Radio, however, was very evidently a distinctly different type of transmission. The radio waves simply traveled in all directions through space as does light or radiant heat.

Researches in Bell Telephone Laboratories have disclosed a new form of transmission for high frequencies. It is unlike radio because the waves are not broadcast through space, but follow a physical guide comparable to a wire. No return path, however, is required of the kind that is commonly assumed in the usual case of transmission. With an ordinary concentric

**By G. C. Southworth,**  
Radio Research Dept., Bell Telephone Laboratories

conductor, such as is used for feeding a radio antenna, the outer tube forms one side of the circuit and the central

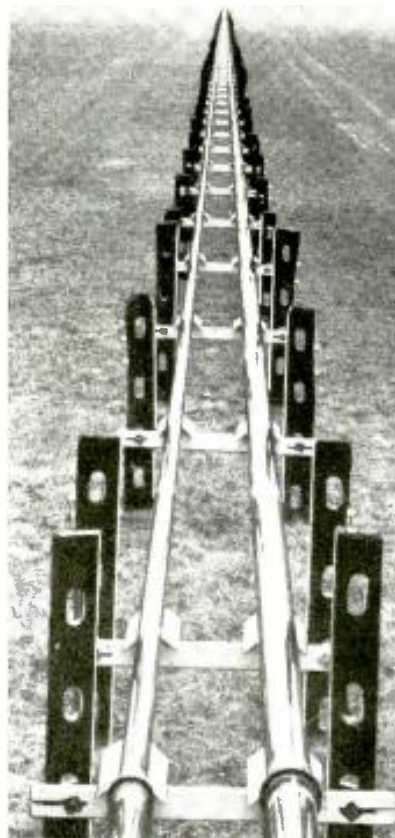

A striking view of the experimental wave-guides at the Holmdel Laboratory.



Photos courtesy Bell Telephone Labs.

A. E. Bowen at the receiving end of the transmission line.

ductor could then be completely withdrawn and still the structures would be able to transmit power. It would be necessary, of course, to provide a suitable means for launching the waves, and the form of transmission would be radically different.

In this example the pipe would have had to be at least  $4\frac{1}{2}$  inches in diameter, but if the pipe had been filled with an insulating material having a dielectric constant of 4, a  $2\frac{3}{4}$ -inch pipe could have been used, while if the dielectric constant had been 9, a 1 $\frac{1}{2}$ -inch pipe could have been used. As a matter of fact, the outer pipe itself may also be done away with, and the transmission will take place along a wire or rod of insulating material, and the attenuation will be least when the resistivity of the insulator, acting as a guide, is the greatest.

Incredible as these phenomena may seem at first sight, they are readily explicable on mathematical principles that have been known for many years.

As early as 1897 Lord Rayleigh obtained solutions for certain differential equations occurring in electrical theory that indicated that wave power could be propagated through either hollow metal pipes or through dielectric rods.

(Continued on page 233)



G. C. Southworth holding one of the resonant chambers used for tests of wave-guide transmission. Behind him are the two transmission lines.

conductor the other. If, however, instead of operating such a structure at a frequency of about a million cycles, approximately the average frequency for broadcasting, a frequency of two-thousand million cycles were employed, it would be found that the central con-



# SHORT WAVES and Our Readers Forum LONG WAVES



## FRESNO, CALIF.. LISTENING POST

*Editor, Short Wave Craft:*  
Herewith a photo of myself and "listening post." My antenna is 105 feet long, L. type, pointing northwest, and constructed of No. 12 copper wire. My ground is composed of two pipes, 6 ft. long and 3 ft. apart, coupled together.  
With the aid of the wave-trap I am able to tune my antenna to any desired (Continued on page 241)



## A VOICE FROM KIRKLIN, IND.

*Editor, Short Wave Craft:*  
Photo shows my modest "Listening Post" in action. (Fig. 2.) This picture was taken with the aid of a photo-flood bulb and a "self-timer" at the moment I heard the call of station YDA, Bandoeng, Java, for the first time!

The receiver was originally the "Doerle Signal Gripper," using the 230 type tubes. The panel and chassis are of aluminum. The outfit is semi-shielded and fits into the wooden box, which opens at the top to facilitate the changing of coils. The panel is held in grooves cut in the sides of the box, thus making it possible to lift the entire contents from the box. This makes rapid changes in wiring, etc., possible.

The original hookup has gone through a process of evolution, so that it now comprises a stage of tuned radio frequency using a 234 tube; a 230 regenerative detector stage; and (Continued on page 241)

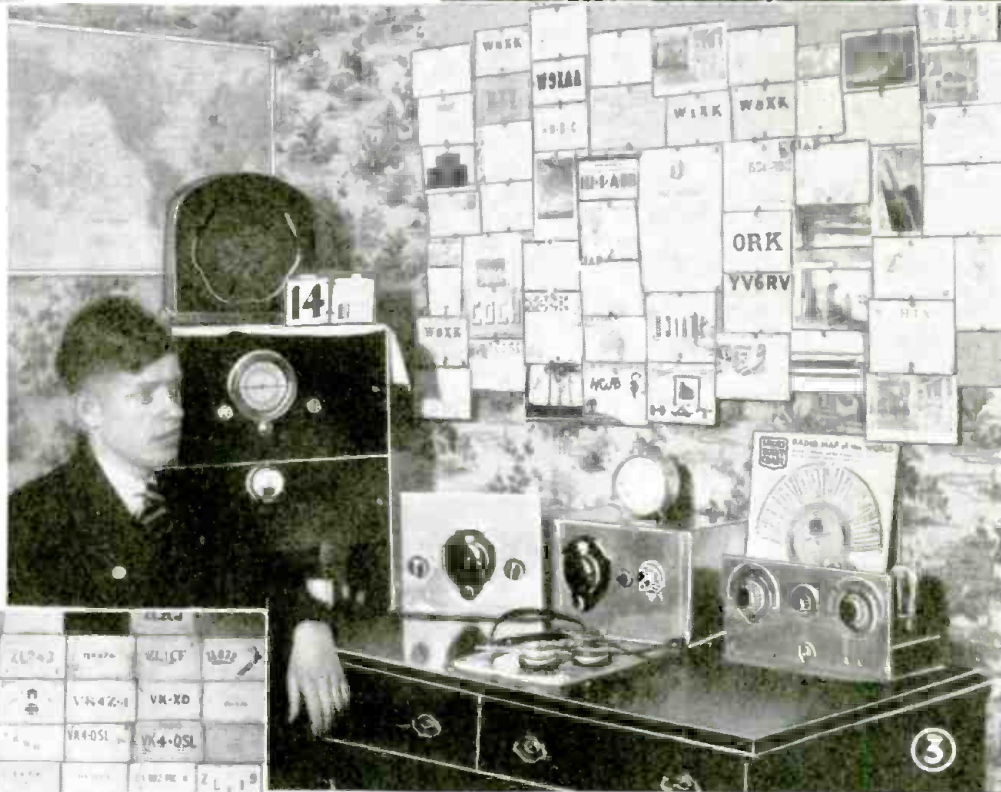

## THIS MONTH'S PRIZE WINNER

*Editor, Short Wave Craft:*  
I am sending you a photo of my "Listening Post." My receivers are home-made, and therefore not of an elaborate nature. I have four receivers, a power-supply, and an amplifier. The receivers can be connected to the power-supply and amplifier at will, by means of plugs. At the left of the photo, is the rack in which the amplifier and power-supply is housed. This consists of an 80, 56, and a 47. On the top shelf is the broadcast receiver using two 58's and one 57. The rack also holds a phonograph and switches which control extra speakers down-stairs. The type speaker (Continued on page 241)

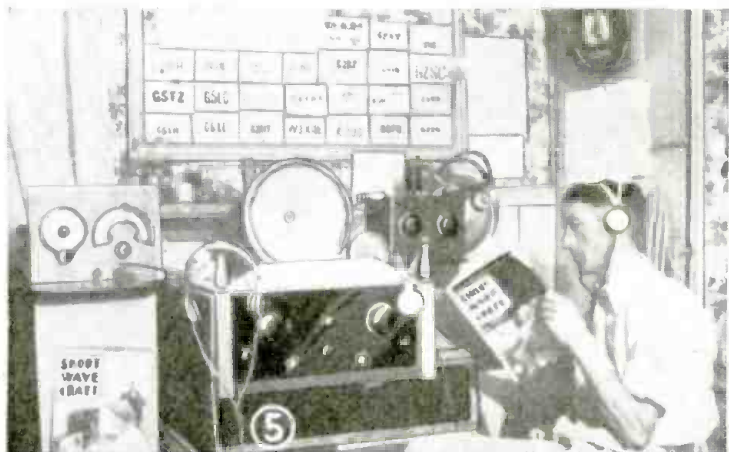

## HE HAILS FROM AUSTRALIA!

*Editor, Short Wave Craft:*  
I am very much interested in S.-W. work, and I thoroughly enjoy each month's *Short Wave Craft*.  
The receiver I am using is a 5-tube commercial set. I also own a 2-tube electron-coupled receiver, using 6C6's and a 41.  
I would like to exchange my Q. S. L. card with any S. W. L. in the U. S. A.

B. HEWERDINE,  
Electra St., Bunaberg, Queensland, Australia.

## "WE'RE THE BERRIES." HE SAYS

*Editor, Short Wave Craft:*  
I enclose herewith photo of my (Continued on page 241)

# Short-Wave RADIO BOMB Locates Mineral Deposits

By W. E. Slope

By means of this new English ultra-short wave invention, the location and diagnosis of various mineral deposits or strata in the earth may be greatly simplified and expedited. The device operates on the principle that various materials such as stone, sand, coal, oil, etc., each have a different dielectric factor and manifest a characteristic reaction on a short-wave oscillator lowered into bores made in the ground. The results are read directly on a meter.

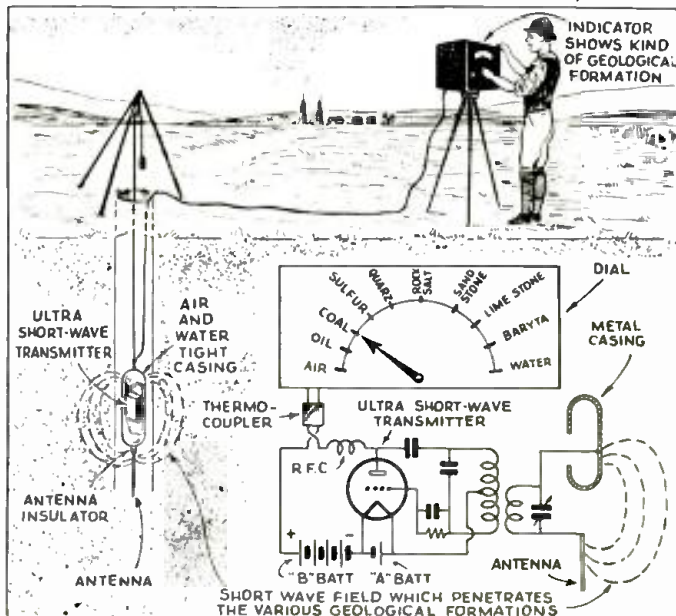

The illustration above shows how the ultra-short wave transmitter or "radio bomb" is lowered down into a bore or hole in the ground, for the purpose of diagnosing the various strata. The wiring diagram shows the general arrangement of the transmitter or oscillator intended for this purpose. The indicating meter may be calibrated so that the various materials can be read off directly for a certain location.

● A SENSATIONAL invention which may give dexterious radio amateurs a chance to make a fortune comparable with the one of early settlers, who often found valuable deposits directly at the earth surface, has recently been made in England. Those early times of settler's fortune have of course passed long ago—since there are but a few spots left where the surface has not

accompanying illustration. There are furthermore many abandoned bores in our country, in which the owners will gladly permit the trial of the new English ultra short-wave invention if a share is promised them. And finally the greatest chance for smart radio amateurs, there are started daily in all parts of the country new bores with the aim of prospecting, and clever radio enthusiasts may be able to earn many dollars if they have the ability to utilize the qualities of the new invention, or to improve its design.

value of the casing-antenna condenser changes, similar large or small changes in the tuning of the output circuit are affected, and subsequently similar changes of plate current occur in the transmitter tube.

The scale of the indicator instrument as shown in the illustration (consisting of mineral indications) is of course omitted in practice. It is actually necessary, before the radio survey is started, to make a new calibration in each case by means of mineral-soil mix-

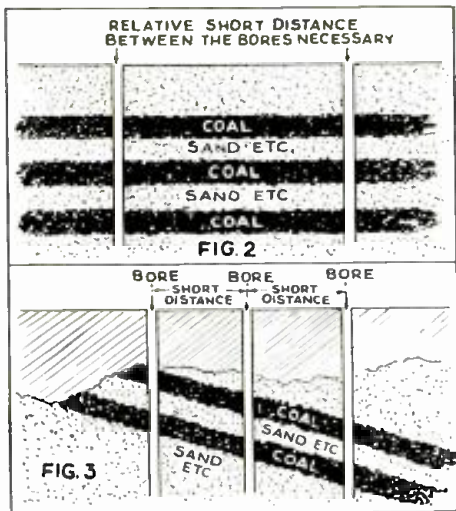

Fig. 2. Diagram above shows a typical cross-section of a section of ground containing deposits of coal, in which the veins run in a nearly horizontal direction. In this case, only a few test bores would have to be made for a comprehensive survey with the "radio bomb." Fig. 3. Here is a different cross-section of ground containing irregular and steeply inclined deposits of coal. Instead of having to drill a great many test bores as required in the older method, it is plain that the new "radio bomb" method of diagnosis of underground deposits will greatly simplify the whole survey, and only a small number of bores will be necessitated.

been searched carefully. However, beneath the surface valuable deposits are still waiting to be found.

There are for example many spots in our mountains—full of clefts—which may offer the opportunity to discover valuable deposits, simply by sending down the radio bomb as shown in the

### How "Radio Bomb" Works

The accompanying illustration Fig. 1, shows how the new apparatus, which discovers deposits, looks, and how it operates. An air and water-tight casing containing a small ultra short-wave transmitter is sent into the bore. Between the metal casing and the attached small antenna, beneath the casing, a powerful short wave field is created. This short wave field which is shown in the illustration in form of dashed lines penetrates the adjacent formation. An indicator instrument connected by cable with the transmitter shows what kind of material surrounds the bore.

Experienced radio amateurs who study the diagram here reproduced have of course long ago discovered that the new apparatus operates through variations of the capacity-value between antenna and metal casing. This is actually the main trick of this interesting geological survey device. The metal casing and the small antenna operate as the two plates of a condenser which are connected, as the diagram indicates, parallel to the tuning condenser of the output circuit. As long as the "radio-bomb" is on the surface, air, which acts in this case as the dielectric material, fills the space between the two "condenser-plates." When the radio-bomb is sent into the bore, instead of air, the various coal, rock-salt or oil-sand formations surrounding the bore operate as dielectric material. Since, according to a physical law, well-known to all radio amateurs, the capacity value of a condenser changes when its dielectric changes, everything else is easy to understand. When the capacity

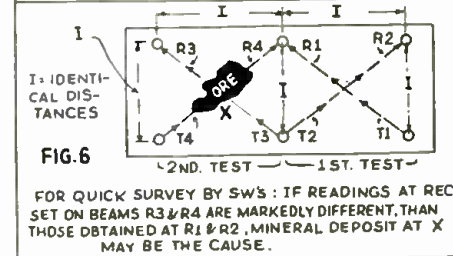
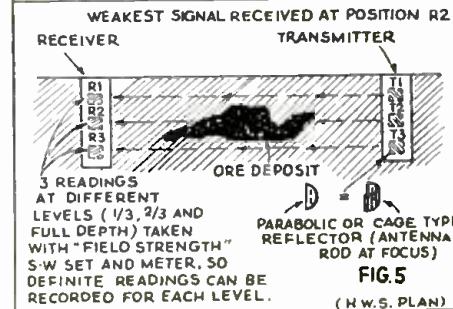
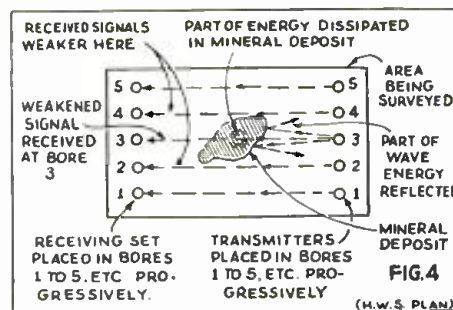
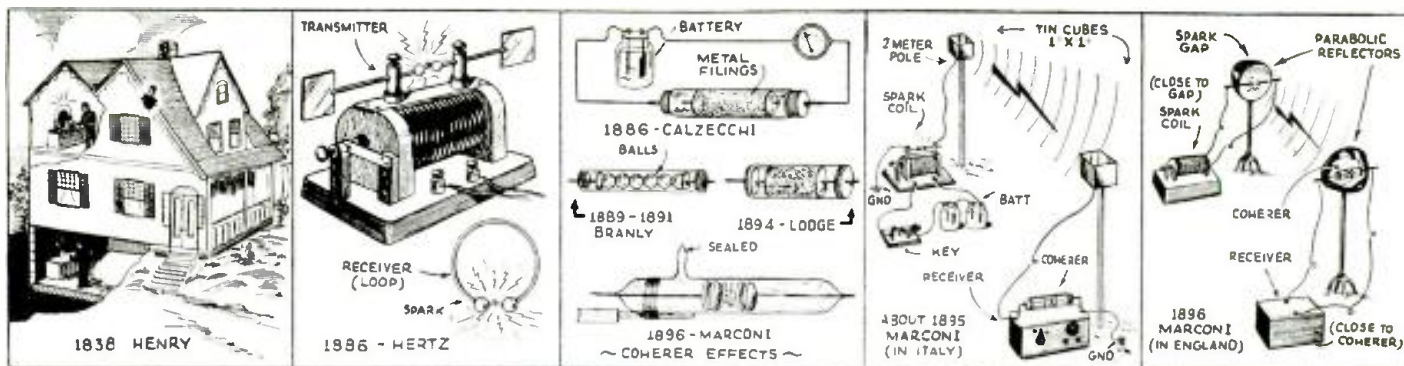

Diagram above show plan for using variation of short-wave method of detecting mineral deposits.



Some interesting phases of early radio history are illustrated above and "Short Waves" were very prominent in the early days of radio.

# Radio 100 Years Old!

## • SHORT WAVES

are *not* new! A strong statement, perhaps, for the present generation of short-wave experimenters to conjure with, but reasonably correct as a study of early radio history shows. Today, one of the most ultra modern developments in ultra short waves comprises a system in which the transmitter and receiver are placed in the focus of a parabolic reflector, the reflectors being pointed toward each other. This system has recently been used for communicating between islands in the Pacific Ocean, as described a few months ago in this magazine, and in the current number there is a similar article describing 9 centimeter waves involving a similar set-up. Let's lift the "curtain of time" and look back on the stage of radio science as it existed forty years ago!

Marconi was using the parabolic reflector system at that time (1896), among many other systems he devised. Of course he had no vacuum tubes, but he placed the *transmitting* and *receiving* apparatus in the focus of parabolic reflectors—and the waves transmitted were *short-waves*! Not as short probably as those of 9 centimeters, but mighty short ones nevertheless, all things considered.

Let's go a little further back into short-wave radio history; we find that nearly one hundred years ago (1838, to be exact), Professor Joseph Henry

By H. W. Secor

In the mad rush of radio improvements—new tubes and new circuits galore—which we face today, it is interesting to stop for a moment and lift the "curtain of time" on some of the early historical events in radio. Was Hertz the first to demonstrate short-wave radio transmission? What did Marconi invent to make radio practical? What of Lodge, Popoff, and many others?

at Princeton experimented with short waves (*Short waves* did not mean anything until quite recently, when that particular part of the radio frequency spectrum happened to become more sharply focussed in the public eye). Professor Henry found that when an electro-static machine was operated and sparks produced, in the top room of his residence, *that currents were set up or induced in an apparatus located in the cellar!* The waves were possibly 1½ to 2 meters in length. Even long before this, however, Huyghens, a Dutch philosopher, who died in 1693, originated the *undulatory theory*, which assumes that light is propagated by the vibrations of an imponderable medium, such as the so-called *ether*.

### The Work of Helmholtz

Helmholtz, born in Potsdam, Prussia, in 1821, as well as Faraday, made many interesting deductions on the possibility of transmitting electrical impulses by vibration. Sewall—in his valuable work "*Wireless Telegraphy—Its Origin, Development, and Inventions*," states that the discoveries and deductions made by Hel-

ward the formation of later wave theories.

James Clerk Maxwell is given credit by most radio historians for formulating the basic theory of electro-magnetic wave propagation. His theory was developed during the period from 1863 to 1873 and his profound mathematical analysis tended to prove that the propagating medium of electro-magnetic waves was *identical with that of light*, but it remained for the great German scientific genius, Heinrich Hertz, in 1886, to demonstrate the correctness of Maxwell's transcending theory.

### Hertz's First Epochal Demonstration

Hertz was a pupil of Helmholtz and from 1883 to 1885 he occupied at Kiel, Germany, the chair of theoretical physics and finally was appointed Professor of Physics at the Technical High School in Karlsruhe. While giving a lecture at that institution and experimenting with a Leyden jar and two flat coils of wire, Professor Hertz noticed that the discharge of the jar through one of the coils, would cause a current to be induced in the other coil, *when there was a small spark* (Continued on page 237)

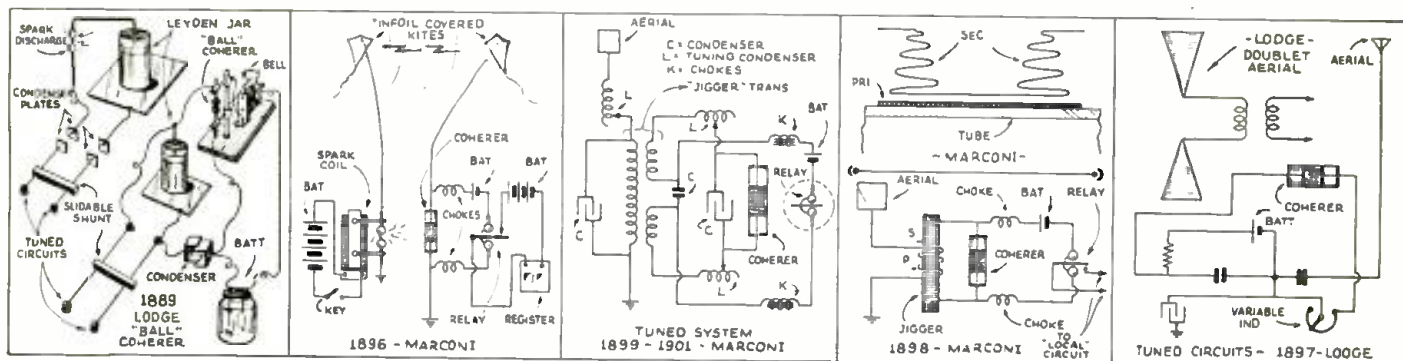

Tuned "short-wave" circuits were devised by Lodge and demonstrated as early as 1890. Marconi demonstrated "tuned" transmitter and receiver circuits about 1899.



Above—A view of the Radio Transmitter Room of the "Queen Mary." The short-wave transmitters in the foreground, as well as the long-wave transmitters, are operated from a Control Room 400 feet distant.

Photo at right, shows a corner of the Radio Control Room on the Queen Mary; receivers at right of photo.

● THE "Queen Mary," new Cunard White Star superliner, makes use of a total of 32 different radio "bands" or wavelengths, made necessary by the extraordinary scope and power of the ship's radio equipment which will link the ship at sea with all the world. The

## "Queen Mary" Uses 32 Different Wave-lengths

wavelengths used will be divided up as follows: 11 for short wave, 9 for radiotelephony (also short wave), 7 for long wave and 5 for medium wave.

For the operation of these wavelengths there will be at least 9 separate aerial systems, comprising one main aerial having a length of 600 feet, 1 auxiliary aerial with a 150 ft. span, 3 short-wave aerials, 3 receiving aerials and 1 emergency aerial. Special arrangements have been made to maintain the permanent watch on the 600 meter wave required by the British Board of Trade under the International Convention for the Safety of Life at Sea.

The elaborate radio installation of the "Queen Mary" is necessitated by the variety of operations aboard the ship involving radio. Every modern device for facilitating the reception of wireless or radiotelephonic communication has been installed so that the "Queen (Continued on page 235)

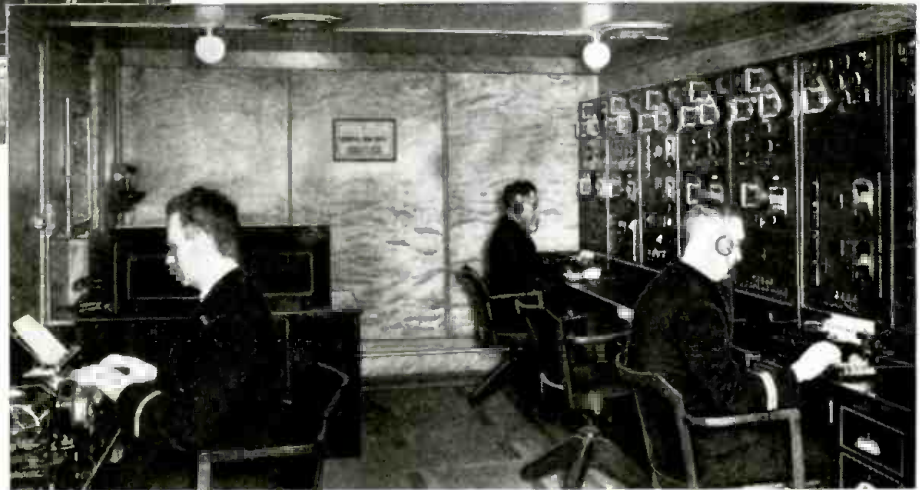

## Where S-W Stations Come In On Your Dial

<p><b>GOOD DAYTIME AND EVENING</b></p>	<p>HVJ - VATICAN (15.12)                  GSF - ENGLAND (15.14)                  W8XK - PITTSBURG, PA. (15.21) "KOKA"                  G50 - ENGLAND (15.18)                  PCJ - HOLLAND (15.22)                  TPA2 - FRANCE (15.24)                  W1XAL - BOSTON, MASS. (15.25) "WEEI"                  W2XE - WAYNE, N. J. (15.27) "WABC"                  GSP - ENGLAND (15.31)                  W2XAD - SCHENECTADY, N. Y. (15.33) "WGY"</p>	
<p><b>GOOD LATE AFTERNOON AND AT NIGHT</b></p>	<p>TPA4 - FRANCE (11.71)                  CJRX - WINNIPEG, MANITOBA. (11.72) "CJRC"                  G5D - ENGLAND (11.75)                  OJD - GERMANY (11.77)                  W1XAL - BOSTON, MASS. (11.79) "WEEI"                  TPA3 - FRANCE (11.88)                  2RD - ITALY (11.81)                  W2XE - WAYNE, N. J. (11.83) "WABC"                  GSN - ENGLAND (11.82)                  W8XK - PITTSBURG, PA. (11.87) "KOKA"                  RNE - RUSSIA (12.00)</p>	
<p><b>GOOD AT NIGHT</b></p>	<p>G5B - ENGLAND (9.51)                  W2XAF - SCHENECTADY, N. Y. (9.53) "WGY"                  DJA - GERMANY (9.56)                  W1XK - SPRINGFIELD, MASS. (9.57) "WBZ"                  G5C - ENGLAND (9.58)                  W3XAU - PHILADELPHIA, PA. (9.59) "WCAU"                  2RO - ITALY (9.63)                  EAQ - SPAIN (9.87)</p>	
<p><b>GOOD AT NIGHT</b></p>	<p>VE9DR - MONTREAL, QUE. (6.00) "CFCF"                  W8XAL - CINCINNATI, OHIO. (6.06) "WLW"                  W3XAU - PHILADELPHIA, PA. (6.06) "WCAU"                  VE9CS - VANCOUVER, B. C. (6.07) "CFCF"                  W9XAA - CHICAGO, ILL. (6.08) "WCFL"                  VE9BJ - ST. JOHN, N. B. (6.09) "CFBO"                  CRCX - TORONTO, CANADA (6.09) "CRCT"                  W9XF - CHICAGO, ILL. (6.10) "WENR"                  W3XAL - BOUND BROOK, N. J. (6.10) "WJZ"                  CHNX - HALIFAX, N. S. (6.11) "CHNS"                  W2XE - WAYNE, N. J. (6.12) "WABC"                  W8XK - PITTSBURG, PA. (6.14) "10"                  CJRO - WINNIPEG, MANITOBA. (6.15) "CJRO"                  W3XL - BOUND BROOK, N. J. (6.42) "WJZ"</p>	

RECEPTION CONDITIONS DESIGNATED ARE BASED ON LOCATION OF LISTENER IN E.S.T. ZONE. MAKE ALLOWANCE FOR OTHER TIME ZONES.

# High-Gain "METAL-2" Receiver

For the S-W "FAN" or "HAM"

By Harry D. Hooton, W8KPX



Front view of the 2 metal tube receiver.

The new high-gain metal tube features Continuous "band-spread" . . . 10 to 200 meter coverage . . . Small size . . . Uses two metal tubes. Low Cost . . . Demonstrated "foreign" reception . . . Works on A.C. or D.C. from batteries.



### Uses 2 Metal Tubes; Has Continuous Band-spread Feature

● AN extremely small radio receiver always attracts attention, especially when the midget set gives gigantic results. The little short-wave receiver illustrated and described in this article is part of the equipment included in the author's portable amateur station. Although it was designed primarily for communication work on the 20 and 40 meter amateur bands, it is also a good set for general short-wave use since continuous band-spread over the entire tuning range from 10 to 200 meters can be obtained with standard size plug-in coils. Two metal tubes are used for maximum sensitivity and stability and also because they can stand much more rough treatment than their glass counterparts.

### Regenerative Detector and One Audio Stage

As shown in Fig. 1, the circuit is conventional in every



Another view of the "high-gain" metal tube receiver.

detail—a 6J7 pentode as an electron-coupled regenerative detector and a 6C5 triode as a resistance-capacity coupled audio frequency amplifier. The coils used in this receiver are of the tapped type, although regular two-winding plug-in coils can be used by connecting the tickler in the cathode circuit, as shown in Fig. 1. C1 is the band-setting condenser and is of 100 mmf. (.0001 mf.) maximum capacity; C2 is the 35 mmf. (.000035 mf.) "band-spread" condenser. The antenna is coupled to the grid of the 6J7 through the usual trimmer condenser and the regeneration is controlled by varying the detector screen-grid voltage.

As the photographs and drawings show, the set is extremely small, being built up on a 6x3x2 inch chassis and a 5x7 inch panel. Both the chassis and the panel are cut from a single 7x16 inch aluminum sheet and are laid out and drilled as shown in Fig. 2. Before the chassis is bent, a cut approximately 1/32 inch in depth should be made along the dotted lines, as shown in the drawing. This will allow the chassis to bend square which gives a neat appearance to the finished receiver. A manufactured chassis can be used if desired, but some short wave fans may prefer to construct their own.

The sockets used in this set are of the spring-mounting type which take up an unusually small amount of space on the chassis. These are now obtainable in both bakelite and

isolantite construction and it is advisable to use the low-loss ceramic sockets in both the coil and detector positions in order to keep the losses down to the minimum. The 6C5 socket may be of bakelite since no R.F. appears across its terminals. A drilling template for these sockets is shown in Fig. 2 at "a."

### How Wiring in Tiny Space Is Done

After looking at the bottom view of this midget receiver, the reader will probably wonder how it is possible to wire the set in such a small working space. Like most jobs of this kind it is not so difficult as it appears at first glance—the secret lies in the way the parts are mounted. The sockets are mounted first and the heater, shell, suppressor and cathode circuits are wired in. The tip jacks, the antenna and ground binding posts and the fixed condensers are next, the connections being soldered as each is mounted. Finally, the off-on switch, the "band-setting" condenser and the potentiometer are placed in their respective positions and wired as shown in Fig. 1.

All wiring between the various parts of the circuit is kept as short and direct as possible and the connections are well soldered. The usual No. 14 bus wire should not be used for making the connections, as it is extremely difficult to handle in a small chassis of this size; the ordinary No. 22 or No. 24 D.C.C. or enameled magnet wire will be satisfactory and is easily bent into any desired shape. The holes in the chassis for the grid leak to the (Continued on page 242)

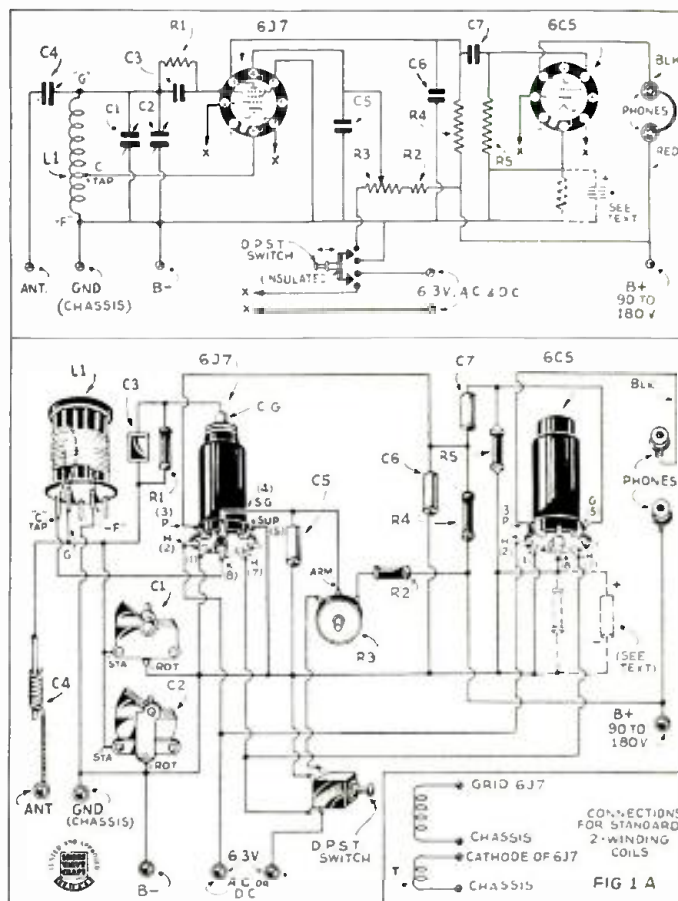

Wiring diagram for the high-gain "Metal-2" receiver.

# Midget "Metal-Tube" All-Wave 4

By H. G. Cisin, M.E.

This extremely compact 4 metal tube receiver will appeal to many readers, as it has its own power-supply built in, as well as a dynamic loud-speaker. It tunes very smoothly and operates from a 110-volt A.C. or D.C. circuit.

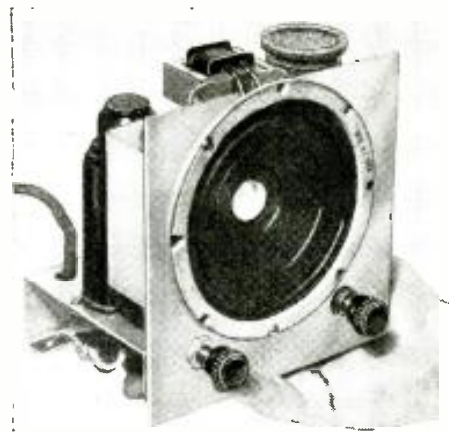

This extremely compact 4-tube receiver with built-in dynamic speaker and power-supply fits comfortably in the palm of the hand.

● SEVERAL months ago the writer described a Midget A.C.-D.C. Set employing three glass tubes. This receiver attracted considerable attention, especially because of its compactness and the many interesting features contained in such a small unit. There has been an insistent demand for a similar set using the latest type *metal tubes* and with *dynamic speaker* instead of the magnetic type, and, therefore, we present herewith the new Midget Metal-Tube All-Wave 4, an A.C.-D.C. receiver for 110 volt operation. It is built up on the same chassis as the three glass tube model, but employs four of the latest metal tubes and a five inch dynamic speaker has been fitted into the set in place of the magnetic speaker. The compactness of the metal tubes has been a great help in fitting four tubes into the space formerly occupied by three tubes.

which uses a 25A6 power output pentode of the latest metal type. This type tube when used on a standard 110 volt line in an A.C.-D.C. circuit,



A rear view of the midget "metal-tube" all-waver, which uses plug-in coils to cover the various bands.

has a power output of approximately one watt. The dynamic speaker is coupled to the 25A6 tube through a 4,500 ohm output transformer, which is a part of the speaker. It is interesting to note that any speaker designed for use with a 45 tube or a 43 tube can be used with the 25A6. The speaker field may have a resistance of from 2,500 to 3,000 ohms.

### New 25Z6 Tube Used as Rectifier

Rectification is accomplished by means of the new metal 25Z6 tube. This is the metal tube equivalent of the 25Z5 tube, with exactly the same characteristics. It has one extra connection which goes to the shielded case of the tube and which must be grounded. The 25Z6 tube provides rectified current not only for the plates and grids of the various tubes, but also for the speaker field. A small 300 ohm choke, by-passed by suitable electrolytic condensers, provides the necessary filtering.

The filaments of the four tubes are connected in series, and a 180 ohm resistor is used to limit the heater current. This latter resistor is contained within the line cord.

### Constructional Details

Starting off with the panel permanently secured to the chassis, the first step is to mount the four "octal" sockets. Next, mount the four-prong coil socket in the position shown in the illustration, using two small but strong right-angle brackets for this purpose. The loud-speaker may next be fastened

(Continued on page 244)

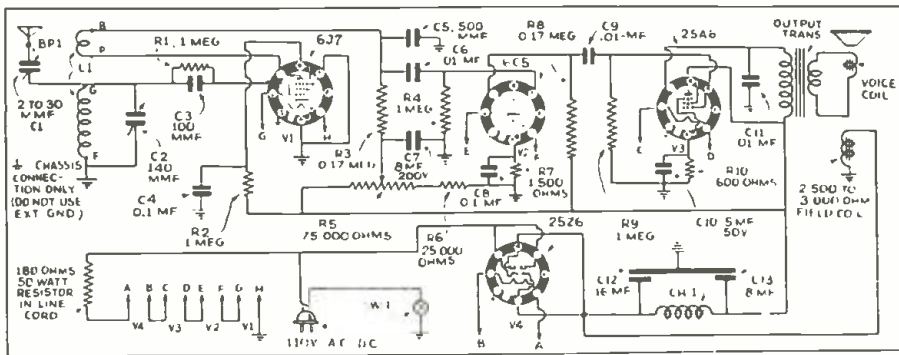

Schematic wiring diagram of the midget receiver using 4 metal tubes, one of which is a rectifier.

able from a standard five-tube A.C.-D.C. receiver. The volume is ample and the selectivity of this set is quite surprising for a receiver with only one tuned stage. The set uses a regenerative detector and two audio stages. The detector is a 6J7 metal tube with regeneration controlled by variation of the detector plate voltage.

### Plug-in Coils Cover All Bands

In order to cover the various bands, Hammarlund plug-in coils are used as in the case of the preceding glass tube model. The antenna trimmer shown at C1, is indispensable in a circuit of this type. Without it, *selectivity*, especially on the broadcast band, would be impossible. The first audio stage is resistively coupled to the detector and employs a 6C5 metal tube. This, in turn, is coupled to the output stage,

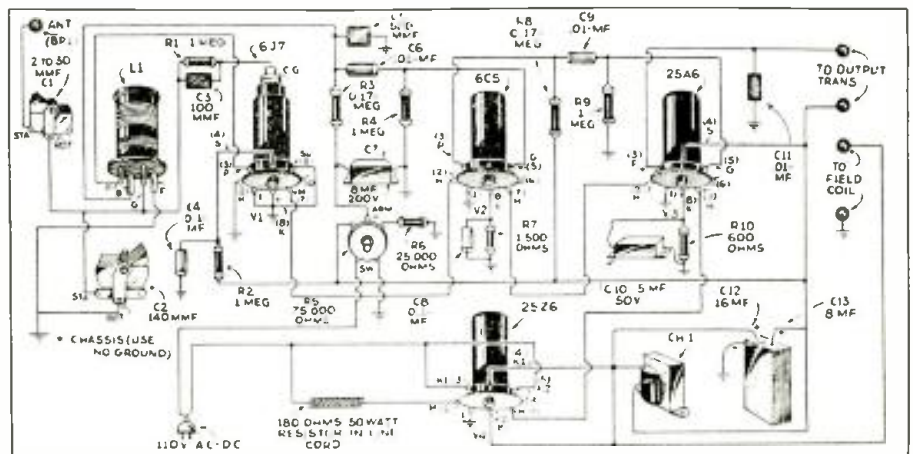

Any one can build this midget receiver by following the picture diagram given above.

# How To Experiment With New Circuits

By Willard L. Miles

New circuits—how to try them out without forever rebuilding the old set—is the main thought expressed here. Simply by changing connections on a few "stock" coil forms, the S-W "Fan" can quickly try out a wide variety of circuits. And all with the same chassis wiring.

● THERE was an article, in the November 1933 issue of *Short Wave Craft*, by Curtis Malsberger, which dealt with methods of "regeneration control" and "radio-frequency coupling." It was a very good article and no doubt was the result of some very tedious research. It was probably the answer to a lot of Hams' prayers for information concerning these two phases of radio, and was very complete.

Nevertheless, while making the tests described, a great deal of the comparisons of performances between types of coupling and regeneration control, were in the main computed at different times and under different conditions. It is practically impossible to have as many receivers as there are methods at the same time in the same place. A considerable amount of work was involved in changing the connections so many times on the same chassis. It was necessary to solder and resolder, and a considerable amount of damage can be caused by heating a condenser or resistor too many times. Also wires crossing each other at different angles in different hookups were bound to produce capacity effects.

If one type of coupling or regeneration control worked exceedingly well on one frequency, it might not work so on another. So it became necessary to find the type which worked, perhaps not as well as the one certain type did on its certain frequency, but rather that it would produce average reception on all bands. Thus the exceptional performance of one type on one band was sacrificed in an attempt to create an all-band combination with average returns, so that the amateur would not be left "up in the air," trying to make up his mind whether or not to build a separate receiver for each band. A rather expensive procedure.

I had constructed the *Master Composite* receiver described several years ago in *Short Wave Craft*, and when I did not get the kind of reception I expected, it became necessary to devise some other method to get every thing I could out of the circuit. It was possible by the aid of condensers and resistances mounted inside the coil-forms, to change the types of coupling between

(Continued on page 229)

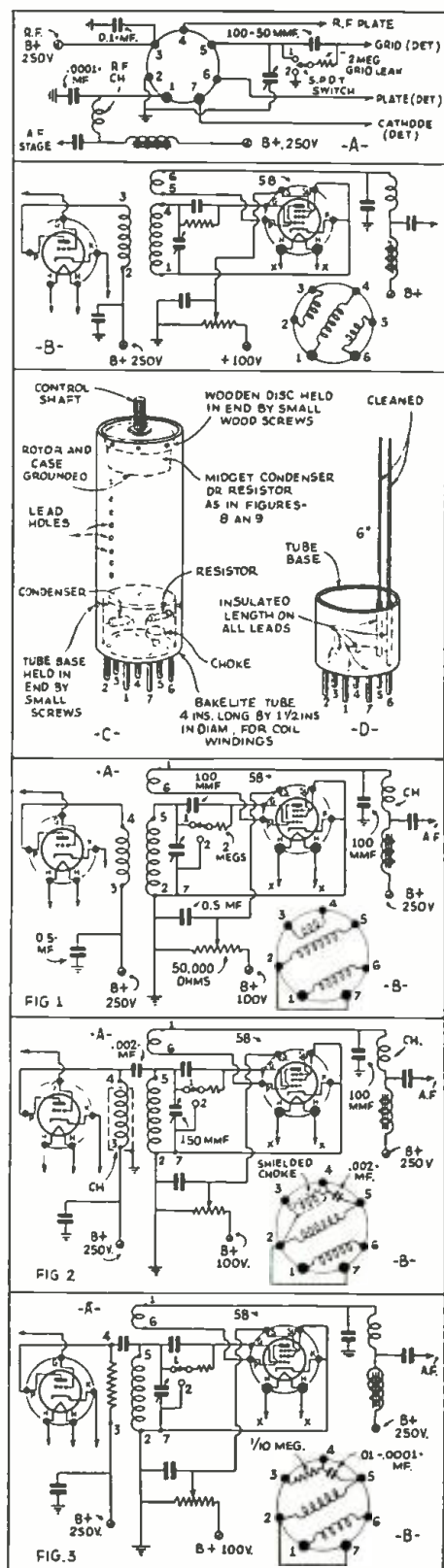
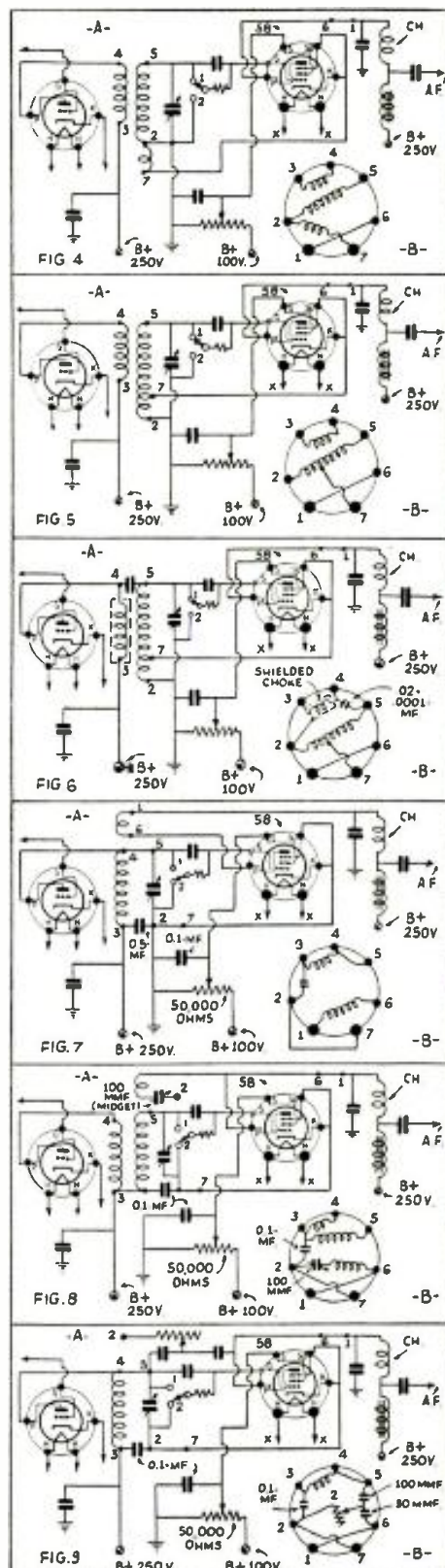
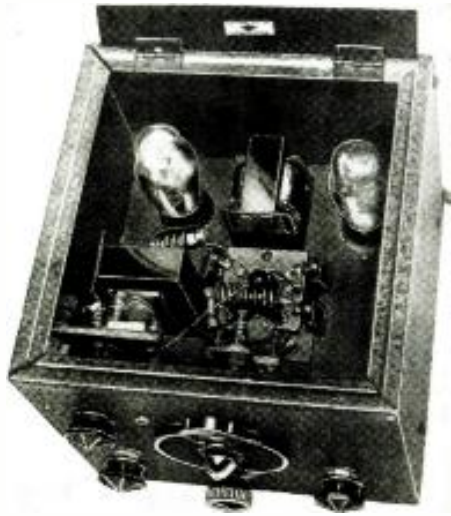

Fig. A—Typical receiver circuit with 7-pin socket. C and D—coil construction details. B—"Composite Receiver" hook-up. Figs. 1 to 3, optional hook-ups, using 7-pin socket.



Using 7-pin socket, numerous "experimental" receiver circuits can be tried out, including different "plate feeds" and electron coupling methods.



# A Sure-Fire 5-METER

By George W.

Here is the 5-meter super-regenerator, which, although employing a very simple circuit, proved to have many a new trick up its sleeve.

● THOSE interested in a *sure-fire* super-regenerative receiver will find this one most interesting. It is extremely simple to build and possesses no trick qualities. In so far as its performance is concerned, this receiver has the stamp of approval of a great many persons.

It was built by the writer over a year ago and has been in constant use ever since. The first person to use it was Arthur H. Lynch, well known operator of amateur station W2DKJ located atop the 40 Wall St., building in New

York City. Through recommendation, many of DKJ's friends have built a similar set and obtained equally as good results. Then early in this year the New York City Police Dept. borrowed this receiver and here too it showed its superiority over a good many others. The tests by the Police Dept. were in contemplation of installing an ultra high frequency radio system. With this record in mind Mr. Lynch suggested that we prepare a story on the set and publish it in *Short Wave Craft*. This receiver design will be used for receiving the reports in the "Ham" network covering the Long Island Sound Yacht races, as described in the June and July numbers.

The receiver is nothing unusual, in that the circuit is a conventional one. It makes use of a 955 "acorn" tube detector, followed by two stages of audio amplification. It is in the detector circuit where the slightly unconventional idea is employed. Back in the October 1935 issue of this magazine, we find a tuned R.F. receiver described, which employed a high "C" in the detector circuit; this detector circuit is exactly the same.

It was found during experiments with the TRF receiver, that by using a large

**Parts List 3 Tube, 5 Meter Receiver**

- 4—.0001 mf. mica condensers, Aerovox.
- 1—.001 mf. mica condensers, Aerovox.
- 2—15 mmf. tuning condensers, National.
- 1—.25 mf. fixed condenser, Aerovox.
- 1—1 mf. fixed condenser, Aerovox.
- 1—.01 mf. by-pass condenser, Aerovox.
- 1—10 mf. low-voltage electrolytic condenser, Aerovox.
- 1—2.5 mh. R.F. choke.
- 1—35 mmf. variable padder condenser, National.
- 1—½ meg. ½ watt resistor.
- 1—75,000 ohm, 1 watt resistor.
- 1—2,000 ohm, 1 watt resistor.
- 1—500 ohm, 1 watt resistor.
- 1—50,000 ohm potentiometer.
- 1—500,000 ohm potentiometer.
- 2—3:1 audio transformers.
- 1—Acorn tube socket, National.
- 1—5 prong wafer socket, Eby.
- 1—6 prong wafer socket, Eby.
- 1—SW3 cabinet, National.
- 1—dial, National.
- 1—955 tube, RCA.
- 1—37 tube, RCA.
- 1—42 tube, RCA.

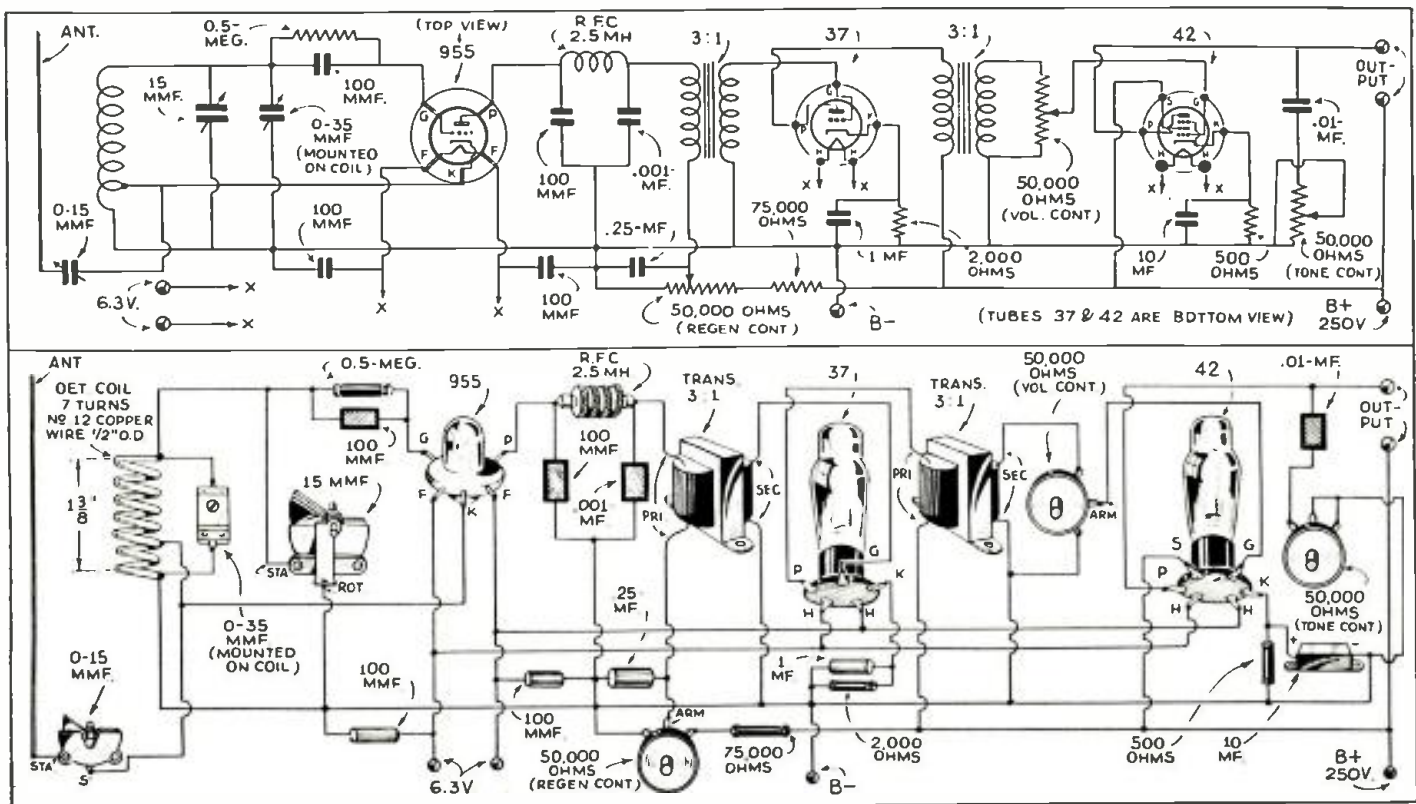

Wiring diagram of the "sure-fire" 5-meter super-regenerator.



The receiver described in this article has been in use for over a year; for many months it was used in conjunction with the 5-meter apparatus at 40 Wall St., New York City, under the call of W2DJK, operated by Arthur H. Lynch, well-known to the 5-meter Gang. This receiver also made the rounds of the N.Y. Police Department, and among all those tested by the "P.D." this receiver gave the most outstanding performance, considering its simplicity and low cost of construction. Then, too, it was on this receiver that mid-western stations were received with R8 volume in the New York City area.



out so well. This method changed the tuning considerably and the slightest amount of coupling knocked the detector out of oscillation. By coupling to the

low potential side of the grid coil, we eliminated all the aforementioned evils. A change in antenna coupling adjustment has practically no effect on the detector and the set is far more stable in operation. We also find that this method permits a more effective degree of coupling to be obtained, and if we are work- (Continued on page 231)

# Super-Regenerator

Shuart, W2AMN

amount of capacity in the detector circuit, the gain in sensitivity and audio level was enormous. Many will recall that with the 955, when used as a self-quenching detector, the signal output is very low as compared with the average triode, such as the 56 or 76. And a good many of the 5 meter boys have gone back to the standard triode for that particular reason. However if the amount of inductance is lowered and the total capacity in the circuit is raised, they will find that the 955 works just as well as the other tubes and is more stable, far more sensitive and provides just as much audio volume.

Of course we could not use a very large tuning condenser because our hand-spread would be lost and tuning would be very difficult. This is overcome by using a parallel shunt capacity in the form of a 35 mmf. variable mid-gate padding condenser. This condenser is soldered directly to the small plug-in

coil so that, should we decide to shift the receiver to other bands, no readjustment will be necessary. After this condenser is once adjusted to bring the band within the range of the 15 mmf. tuning condenser, it requires no further attention. This high "C" arrangement also makes the tuned circuit slightly more selective and permits duplex operation with much less interference from the local transmitter.

Coupling the antenna to the detector circuit offered considerable difficulty. The usual method of coupling the antenna to the detector through a small condenser directly to the grid side of the coil did not work

A close-up of the chassis of the 5-meter super-regenerator, which has demonstrated through lengthy tests, that it can "swing circles" around practically every other receiver of its type.

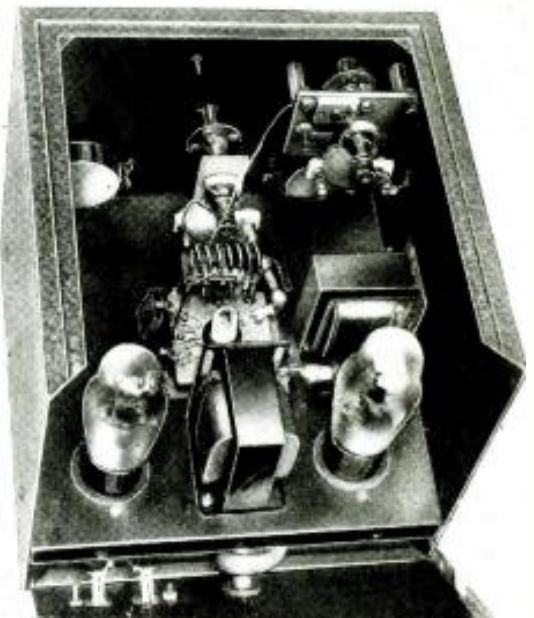

# Ultra Short-Wave Super-Het.

With Pre-Selection Stage . . .

By C. W. Palmer



The ultra-short wave super-het with pre-selector stage here described.

● THE trend toward ultra-high-frequency operation has brought about a demand for really effective receivers, to take advantage of these frequencies and their unusual characteristics.

It has been generally conceded by those who have used these frequencies, that the superheterodyne circuit is the most effective, since adequate gain, high selectivity and sensitivity can be obtained. However, most of the su-

amplification are used, difficulty is encountered in stabilizing the set—and even when stability has been achieved, the problem of noise remains since the I.F. amplifier does not affect the signal-to-noise ratio.

The solution to the problem is, of course, to use 2 I.F. stages with a properly designed preselector stage before the frequency-changer. On the broadcast band and the lower frequency part of the short-wave spectrum, it is easy to secure high gain from such a preselector stage, for tuned circuits of high dynamic resistance are readily constructed and tubes have high input impedances at these frequencies. Also, the frequency is low enough so that feed-back through the grid-plate capacity is not annoying. None of these factors apply on the ultra-short wavelengths.

The problem of attaining a high dynamic resistance for the tuned circuits is the first to be tackled—for with any given tube, the gain of the stage (Continued on page 248)

perhets that have been made up to this time, for ultra-short-wave reception, have been made with the frequency-changer coupled directly to the aerial and without any preselection.

In some experiments conducted recently by the staff of the English magazine *Wireless World*, it was found that aside from the important point of signal-to-noise ratio, it was difficult to obtain sufficient I.F. amplification with stability in these sets.

The intermediate frequency usually chosen for ultra-high-frequency superhets is in the neighborhood of 5 mc. and two stages supplying a gain of 50 per stage are inadequate unless an excessive amount of A.F. amplification is used to bring up the signal level to speaker volume. If three stages of I.F.

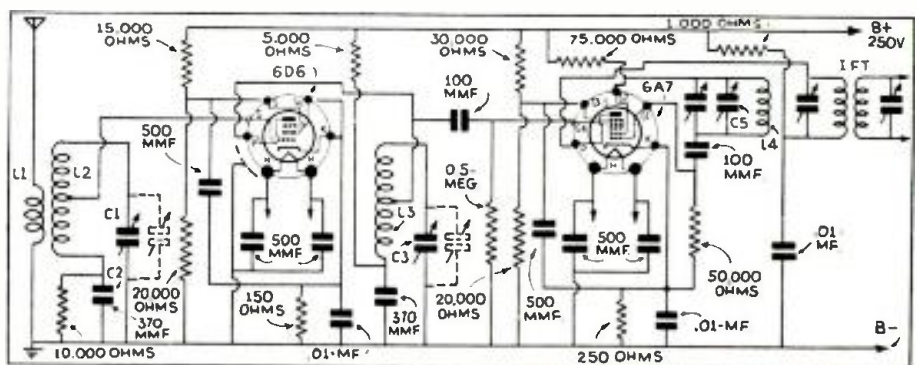

Diagram of the new circuit devised for an ultra-short wave superhet, with pre-selection stage.



much these tubes could be pushed before they "went west," although during one experiment we were able to drive them to the tune of over 90 watts output! And even here they showed no signs of overheating and they were operating well within the rated 24 watts plate dissipation specified by the manufacturer as maximum for a single tube as an audio amplifier.

While operating on 40 meters one time we decided to make a quick shift to 20. We merely changed the amplifier plate coil and doubled in that stage,

Watch for following articles in which the new 6L6 Beam tube will be used. Last-minute tests indicate even greater possibilities than those already recorded.

and surprising as it may seem, the output was just about the same as when the amplifier was operating on the fundamental. The plate dissipation also remained the same. We have made all possible tests with this transmitter and we can assure our readers that operation on three bands, with only two stages and a single crystal, is now possible and the output is nothing to sneeze at either!

Voltage and Current Values for Screens and Plates

With the transmitter delivering power to the antenna we recommend the following voltage and current values. Oscillator plate—250 volts; screen 150 to 200 volts; the combined screen and plate currents 30-40 ma.; amplifier plate 575 to 600 volts at 150-200 ma.; amplifier screens—250 volts at 30 ma. These are the conditions under which the transmitter was operated for weeks during tests. The grid current of the amplifier ranged between 10 and 20 ma. The output was greater with lower current, but the plate current would creep

when the amplifier was running unloaded with low grid current. However, when loaded, no signs of creeping were evident—even with the grid current as low as 5 ma.; the recommended value would be 10 ma.

The first set-up used battery bias on the amplifier, but did not work out so well. With fixed bias the screen voltage and current ran all over the scale, as the excitation was changed, and presented all kinds of difficulties. We immediately changed to grid-leak bias and our troubles were over. A small fixed resistor was put in the cathode circuit to limit the plate current to about 100 ma. should the oscillator fail and thus remove the bias obtained via the leak.

When contemplating the use of these tubes as amplifiers, we were worried about neutralizing because we knew that the plate-grid capacity must be small and of course we could not expect it to be a thoroughly shielded tube. By tapping the plate coil, only a few turns from one end, rather than in the center and with the use of a 15 mmf. condenser, we were able to obtain the desired results. This condenser by the way neutralized the amplifier with its plates just slightly meshed. No R.F. chokes were used at first and we experienced difficulty with feed-back and oscillation in the amplifier. This was overcome by the 2.5 mh. choke in the plate lead, just as shown in the diagram. We mention this because some reader may try leaving it out and not find the trouble. With excitation removed, that is with the oscillator off and the amplifier voltages on, the amplifier showed a tendency toward self-oscillation on some frequencies. But with excitation the amplifier is absolutely stable with no signs of oscillating by itself.

The transmitter is constructed in three units; one is the oscillator, another the other amplifier and the third is the power-supply. (Continued on page 216)

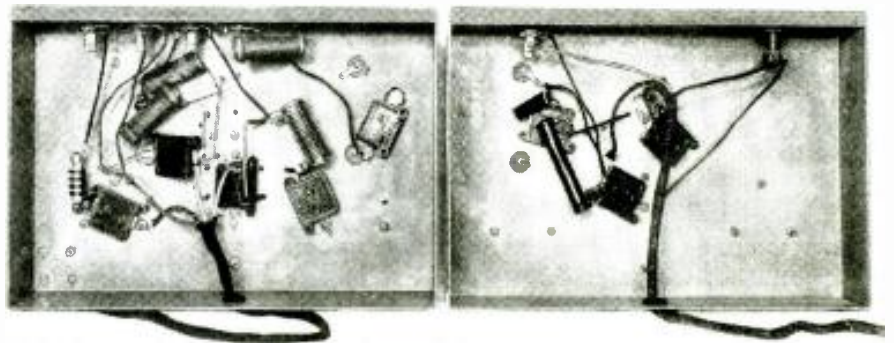
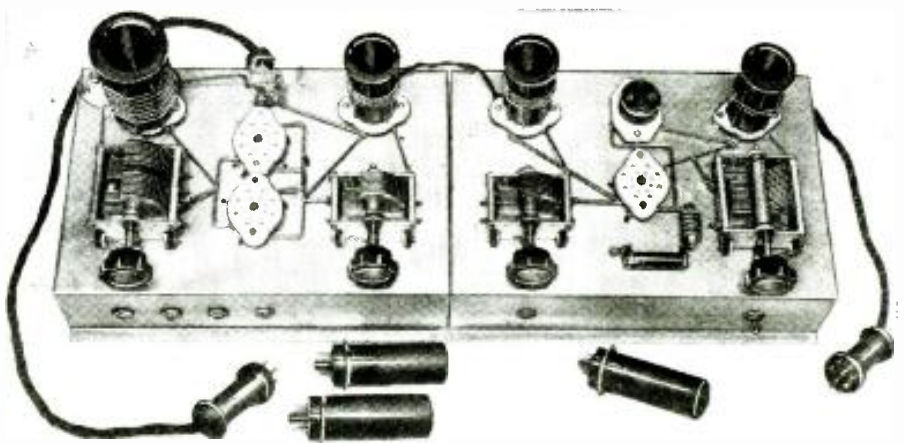

Top and bottom views of the oscillator and amplifier units.

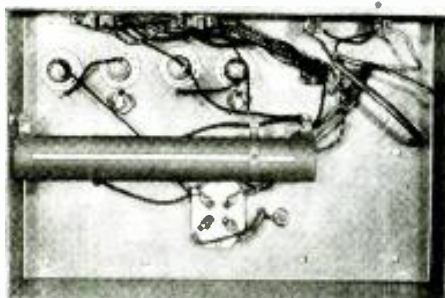
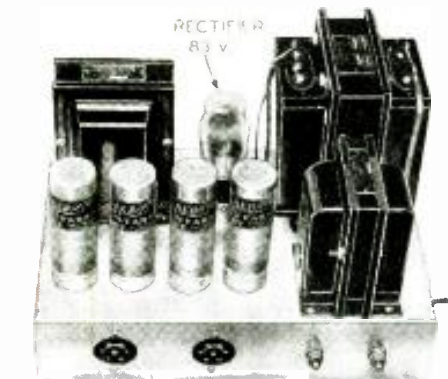

Top and bottom view of the "heavy-duty" power-supply used with the Beam tube transmitter.

Parts List for Oscillator Stage

- 3—.001 mf. condensers, Aerovox.
- 1—260 mmf. variable condenser.
- 1—150 mmf. variable condenser.
- 3—5 prong isolantite sockets, I.C.A.
- 1—toggle switch, I.C.A.
- 1—jack, I.C.A.
- 2—2.5 mh. R.F. choke, I.C.A.
- 5—5 prong coil forms, I.C.A.
- 1—80-meter crystal, Bliley.
- 1—150,000 ohm resistor, 5 watts (use several small ones in series if necessary).
- 1—30,000 ohm, 20 watt resistor, Aerovox.
- 1—8 prong isolantite socket, I.C.A.
- 1—single closed-circuit jack, I.C.A.
- 2—pointer type knobs, Crowe.
- 1—6L6 tube, R.C.A.
- 1—6 prong cable plug, I.C.A.
- 1—0-200 ma. meter, Triplett.

Amplifier Parts List

- 4—.001 mf. mica condensers, Aerovox.
- 1—150 mmf. variable condenser.
- 1—split stator condenser, 150 mmf. per section.
- 1—2.5 mh. R.F. choke, I.C.A.
- 1—10,000 ohm resistor, 10 watts, Aerovox.
- 1—10,000 ohm resistor, 20 watts, Aerovox.
- 1—150 ohm resistor, 10 watts, Electrad. (must be capable of carrying 250 ma.)
- 2—5 prong isolantite sockets, I.C.A.
- 2—8 prong isolantite sockets, I.C.A.
- 1—15 mmf. Trim-Air condenser.
- 1—single closed circuit jacks, I.C.A.
- 1—toggle switch, I.C.A.
- 2—pointer type knobs, Crowe.
- 2—6L6 tubes, R.C.A.
- 1—6 prong cable plug, I.C.A.
- 20—40-80 meter plug-in plate coils, I.C.A.

Parts List for Power Supply

- 1—400 ma. transformer with 1.100 volt secondary, Thordarson.
- 1—combination filament transformer, 3 windings (see diagram), Thordarson.
- 1—19 henry filter choke, 250 ma. or greater carrying capacity, Thordarson.
- 4—500-volt peak, 8 mf. electrolytic condensers, Aerovox.
- 1—25,000 ohm resistor, 200 watts, with slider, Aerovox.
- 1—4 prong wafer socket, Eby.
- 2—6 prong wafer sockets, Eby.
- 1—83-V tube, RCA.
- 2—toggle switches, I.C.A.

# Improving the 2-Volt Superhet Receiver

By H. D. Hooton, W8KPX



The revamped 2-volt superhet, with regeneration feature added.

In the last issue there was described by the author an excellent 2-volt superhet; in the present article he describes how to add regeneration to the second detector, so as to permit reception of unmodulated C.W. signals. This feature also boosts the sensitivity of the set to a considerable degree.

● WHILE the 2-volt superheterodyne, as described in the July number, is an excellent receiver for the short wave "fan" and the phone "ham," it has one serious disadvantage when observed from the code operator's point of view—it does not receive unmodulated CW signals. Of course a *beat oscillator* can be used for this type of reception, but this set was designed especially for operation on dry cells

and the addition of another tube would place an excessive drain on the "A" supply. The author decided to experiment with a *regenerative* second detector and also to work out some method of replacing the plug-in coils with a band-switching system. The results of these experiments are described in this article.

### Tickler Coil Added to Output I.F. Transformer

In order to dismantle the output I-F transformer so that a *tickler* can be wound on its core, spread the mounting lugs slightly and remove the nut and lock washer from the top of the shielding can. Now grasp the four lead wires with one hand and, holding the can firmly with the other, pull gently. If the core assembly cannot be readily removed, run the point of a knife around the waxed cardboard in the bottom of the can in order to loosen it. After the transformer has been removed from the can, the large square nut at the top is removed which will allow the trimmers to be taken off the core. If extreme care is used during this dismantling process, the trimmers can be shoved over to one side and the regeneration coil wound directly on the core without unsoldering any of the connections or disturbing the adjustment of the trimmers. The coil at the top of the can, nearest the trimmers, is the grid coil.

The tickler itself consists of 80 turns of No. 32 silk-enameled wire, jumble wound (helter-skelter; not in even layers) about one-half inch from the grid coil. The coil should be wound in the same direction as the grid coil if the direction of its winding can be determined. If the coil is covered with wax it should not (Continued on page 245)

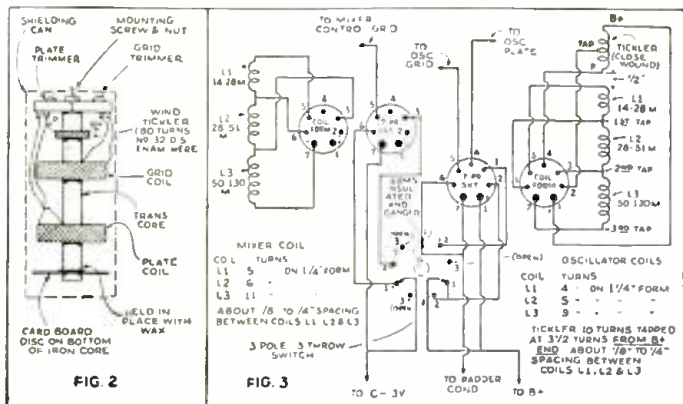

Illustrations above show how regeneration or "feedback" coil is added to the second I.F. transformer, and also the improved hand-switching scheme for the main tuning inductances.

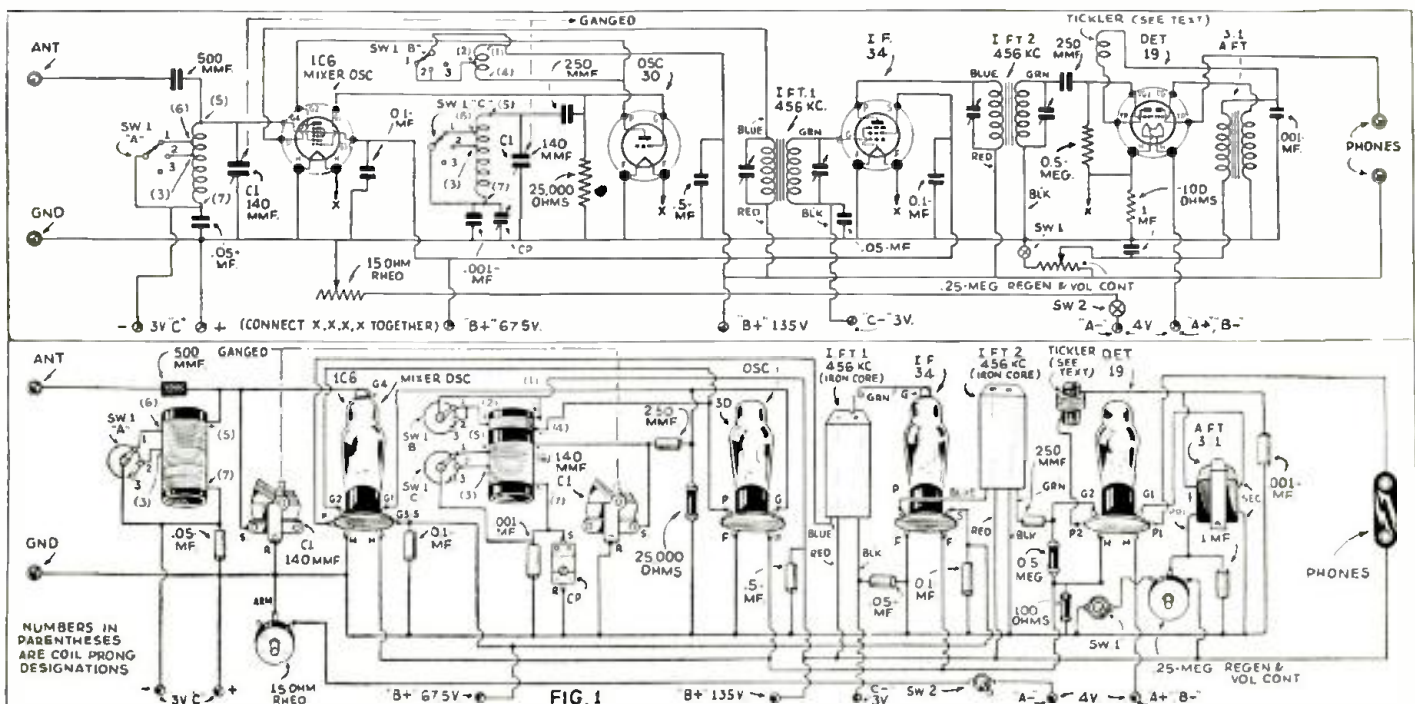

The revised hook-up for the 2-volt superhet described in the last issue, which now provides regeneration in the second detector.

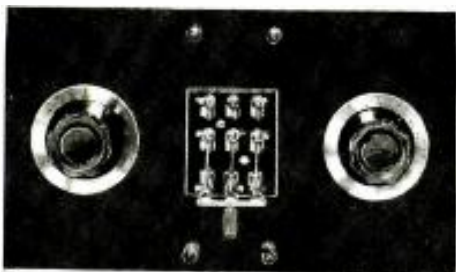

Front view of the tuning panel for use with the "all-band" transmitting doublet.

# ALL-BAND TRANSMITTING DOUBLET

## How To Make and Tune It

● IT IS surprising how little attention the amateurs have given to doublet antennas. For a good many years the doublet was considered only applicable to transmitters operating on one frequency. However, recent experiments have proven that it is possible to construct a *three-band* doublet antenna which has a surprisingly high percentage of efficiency.

One great advantage of the doublet antenna is that it can always be adjusted to be symmetrical—an advantage not found in the Zeppelin type feeding system when connected to the end of an antenna. In a good many cases, the doublet antenna will be found to be more effective than the Zeppelin type, in that the doublet can be tuned to a fairly wide frequency range without disturbing the symmetry of the system.

Let us choose, as an example, a 40-meter current-fed doublet antenna. This antenna we all know is extremely efficient, but reputed to be quite inflexible. By referring to Figs. 1 and 2, we see that in Fig. 1 we have a half-wave doublet—each section being  $\frac{1}{4}$  wavelength long with feeders of any de-

sirable length, up to  $1\frac{1}{4}$  wave lengths. This antenna, and the current distribution shown, is for operation in the fundamental frequencies.

In Fig. 2, we have the same antenna tuned to 20 meters, or the second harmonic. This is a very interesting antenna in that it is really two half-wave antennas fed in phase; which means that we get a considerable gain over the conventional half-wave doublet. This 20-meter phased system is directional broadside; that is, if the antenna were pointing north and south it would be west the same as any other doublet antenna, only to a more pronounced degree. Radiation north and south or

*endwise* is very low, although it is normally quite possible to work stations in these directions, with reports of less signal strength.

In these two we have a very excellent 40-meter half-wave antenna, and on 20 meters where the efficiency of the transmitter is liable to decrease an appreciable amount, we have a phased proposition in the antenna, which provides us with a *gain*. This gain, in many cases, should be sufficient to overcome the losses in the transmitter in (Continued on page 243)

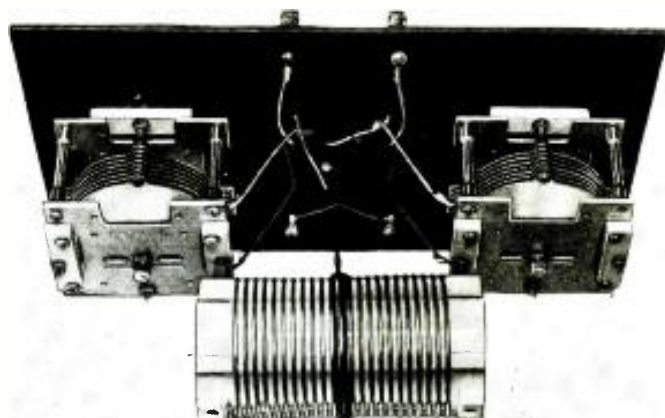

A peek at the rear of the tuning panel shown above — a simple lay-out but a logical one, and a piece of apparatus that will give you a much smoother and more flexible range with an antenna of the type described.

# A Strong, Easily-Made Hole-Cutter

By Henry Laraby

● MOST of the home-built hole-cutters are too hard to make without the use of machine work. Many of the articles describing how to build a hole-cutter, call for materials too hard to obtain easily. Some of the commercial hole-cutters will not stand up and do the work constantly without breaking. A real good commercially made hole cutter costs several dollars, and is too expensive for the average man who needs one only now and then.

The writer has tried out many of the so-called hole-cutters on the market and some of his own ideas, and he has also bored the countless number of small holes that have to be bored by hand to make the socket holes for eight to twelve tube radio chassis socket holes. If you have done this last, you will readily admit the need for an easily made hole-cutter.

The new all metal tubes need a one inch chassis hole for their socket hole. The hole for coil mounting through a chassis is usually one and one-eighth up to one and one-quarter inches. The old style glass tubes required a one and one-eighth inch hole in the chassis for their socket. The hole-cutter shown in size detail will cut holes for the sizes given. If the cutter is to be used for cutting meter holes in panels, the body of the cutter marked two, can be increased in length to take in the hole size needed, or the entire cutter in all its parts can be increased in size and the same manner of construction followed, by using larger nipples, lock-nuts, shank, and a heavier cutting tool.

This type of hole-cutter has many good features. It can be made in one and one-half hours easily. The material needed can be obtained from most any hardware or plumbing supply house. There is nothing fancy to fit or difficult work in making it. The only place necessary for close work if it can be called close, is the square hole through the nipple that holds the square shank. This hole should be square and fit rather snugly about the square shank to prevent shaking. A quarter inch or five sixteenth square file will do the work, after a five-sixteenth inch hole has been bored through the nipple. (Continued on page 245)

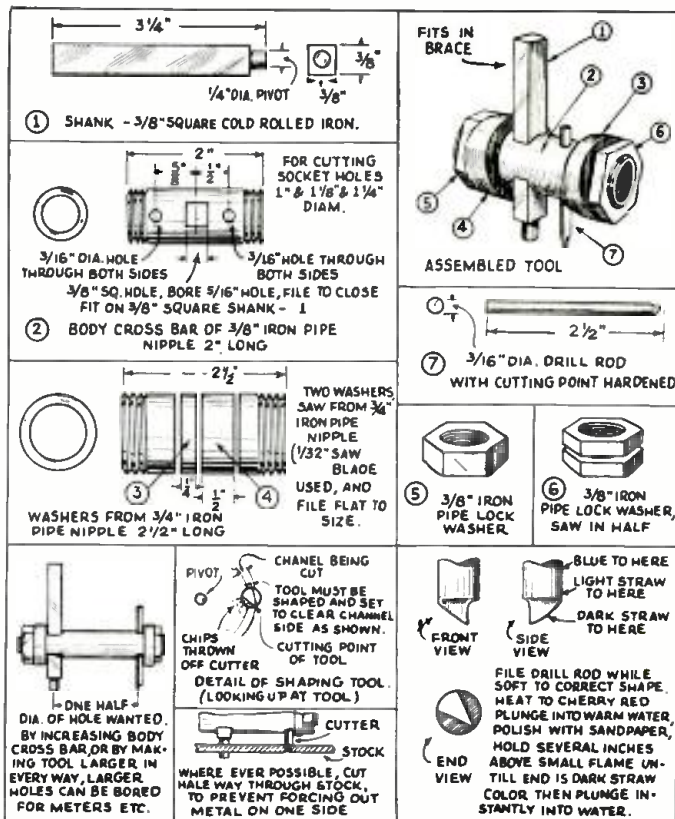

The drawings above show how to make a really strong and yet quite simple "hole-cutter." Those who have had cutters break repeatedly when boring through steel panels or cabinets, will appreciate this excellent design.

\$5.00 Prize

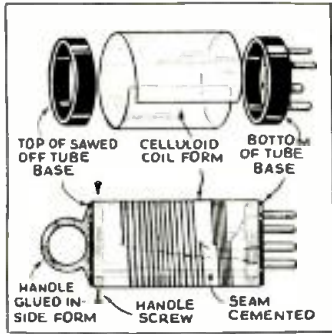

**LOW-LOSS COIL**

I construct my own low-loss coil forms with material frequently found in the average junk-box. All that is needed is some old tube bases, some celluloid, and a bottle of acetone or collodion. Saw a 1/4 inch ring from the top of the tube-base; this will form the upper ring of the coil. The bottom of the tube-base is then cut down to 1/4 inch and used as the base of the coil. The illustration clearly shows the general assembly.—John D. Hockman.

**PLACE FOR UNUSED TUBES**

Finding a place for tubes around the work shop has always been quite a problem. I would like to submit a method which I use to safely place the unused tubes. A heavy piece of corrugated cardboard is placed over a wood frame, as shown in the diagram. Then the tubes are pressed gently

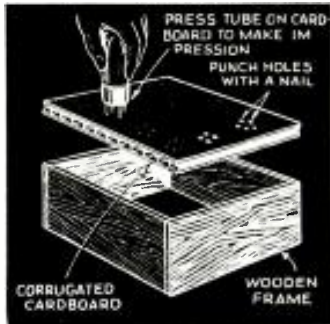

against the cardboard, making marks. After the cardboard is thus marked, holes are punched and tubes inserted in the proper places. This method always holds them firmly in place and the result is a lot of tubes which are always in place and which have "one-piece" glass envelopes.—Robert Mayo Norman.

**DUAL CODE PRACTICE SET**

It is much easier to learn the code if you are communicating with some one. I have arranged this by connecting two keys and

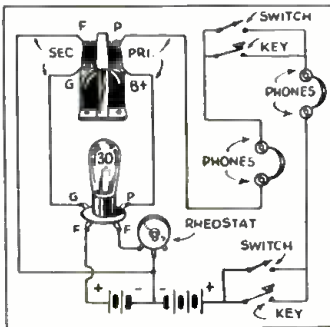

two pair of phones with one oscillator, as shown in the diagram. Break-in system is used the same as in the telegraph circuits. One key must be closed in order that the system may function. If the sending operator makes a mistake, or if you miss a word, merely open the key and the line goes "dead." Not hearing the tone in the phones, he will inquire as to the error.—Venion Clark.

**COIL ADAPTER**

The experimenter may have coils that are not wired for the particular set in which he wants to use them. By making a simple adapter, as shown in the drawing, and having one for each set of coils that are wired differently, no changes in the wiring of

**\$5.00 FOR BEST SHORT-WAVE KINK**

The Editor will award a five dollar prize each month for the best short-wave kink submitted by our readers. All other kinks accepted and published will be awarded eight months' subscription to **SHORT WAVE CRAFT**. Look over these "kinks" and they will give you some idea of what the editors are looking for. Send a typewritten or ink description, with sketch, of your favorite short-wave kink to the "Kink" Editor, **SHORT WAVE CRAFT**.

the receiver will be necessary.—Harold Johnson.



**CRYSTAL HOLDER FROM EARPHONE**

Recently, needing a crystal holder, I constructed one from an old earphone casing. It is only necessary to remove the "works" from the earphone and follow the suggestions set forth in the drawing. The electrodes of the holder must be ground perfectly even on a glass base, using carborundum as the abrasive.—Bob Miller.

**ANTENNA SPRING**

While this "Kink" is not original or new, by any means, I have not seen it printed for a long time, and feel that reprinting it would do no harm. I use a large coil spring connected to one end of my antenna, to allow for swaying of a tree, to which the other end of an antenna is connected. This allows the antenna to be taut at all times, reduces stretching of the antenna wire and prevents breaking during a wind-storm when the tree usually swings considerably.—A. D. Sargent.

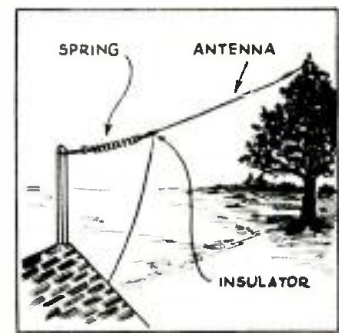

**NEON TUBE OSCILLATOR**

This Kink may not be original but I have not seen it printed in *Short Wave Craft*. It makes an excellent "code-practice" oscillator and can be constructed for about \$1.00. The current flow through the circuit is around 10 ma. Therefore, the battery will last a long time and the tone can be controlled conveniently and effectively with a 0 to 3 megohm variable resistor. The bulb must have enough voltage on it to make it glow before it will oscillate.—Dick Schramm.

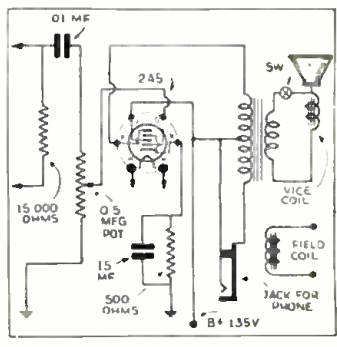
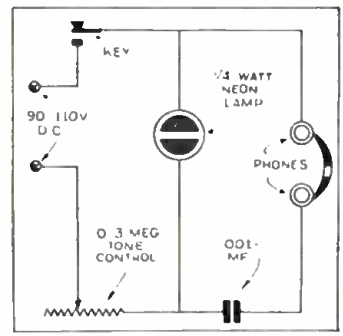

**PHONE CORD KINK**

Many "Fans" and amateurs have spent a good part of their valuable time untwisting the phone cords. Three pieces of rubber hose (smallest diameter that will fit over the cords) will very nicely overcome this bothersome tangling. In the diagram I have illustrated how each leg of the phone cord is run through the hose and all three are bound together with adhesive tape. Try this when you are tired of untwisting your phone cords.—Harry Pasquay.

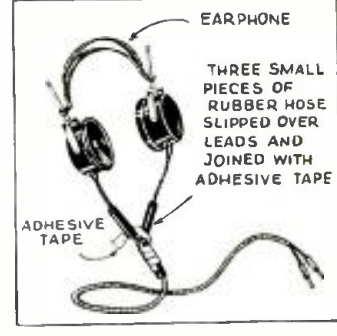

**EARPHONE CASE**

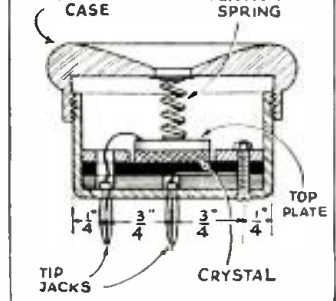

**MOUNTING-RACK FOR VERIS**

Providing a place for the great number of "veril" cards received has always presented quite a problem. Also, a number of good suggestions have been given in your "Kink" Department. Mine consists of a neatly finished board, slotted as shown in the drawing, with two large loops. On these loops I have placed a number of ordinary paper clips which are used to support the veril cards. At any time a card may be removed without disturbing the entire group. This idea has worked very satisfactory and I am passing it along to other readers of the "Kink" page.—Frank Stein, Jr.

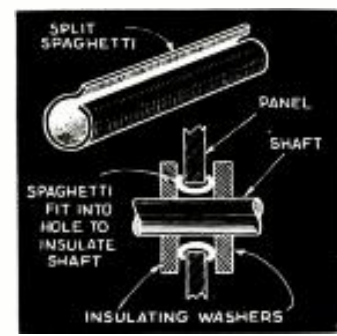
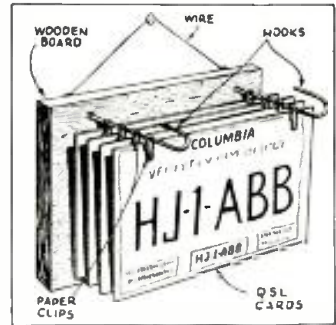

**INSULATOR GROMMET**

Many short-wave set constructors have found the need for an insulating grommet, just at a time when none were available. By cutting a piece of spaghetti tubing, as indicated in the diagram, a simple and effective insulator may be made. This is placed around the inside of the hole in a metal chassis, so that the ends just meet. Complete details are shown in the sketch.—Robert Wyatt.

**HEADPHONE CONNECTION**

I am submitting my "favorite Kink" for the benefit of those who desire to connect earphones to a receiver while a loudspeaker is operating. As most speakers have transformers which are center-tapped, I merely connect the earphones to one side of the transformer input winding. This is, of course, where single-ended audio amplifiers are used. In this manner, there is no direct current flowing through the earphones. If one does not want the phones to connect directly to the B plus, as in this diagram, then a .1 mf. condenser could be connected in series with each lead. This will isolate them and prevent any danger of shock. Another method which could be used would employ a .1 mf. condenser connected in series with one leg of the phones going to the coil on the transformer, and the other side of the phones could be connected directly to the B minus.—DeWitt E. Harvey.

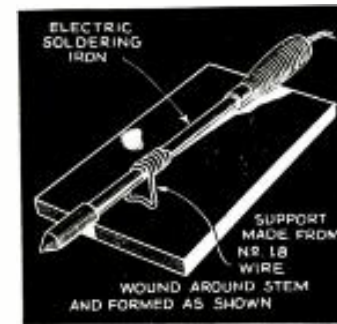

**PERMANENT IRON HOLDER**

During my experimental set construction, I found that this soldering iron holder gave the greatest satisfaction. As can be seen in the drawing, I merely form No. 12 bus-bar loosely around the iron. This will fall downward and always be in the correct position when you lay the iron down.—J. Esterhuizen.

# World Short-Wave and Time-Zone Map

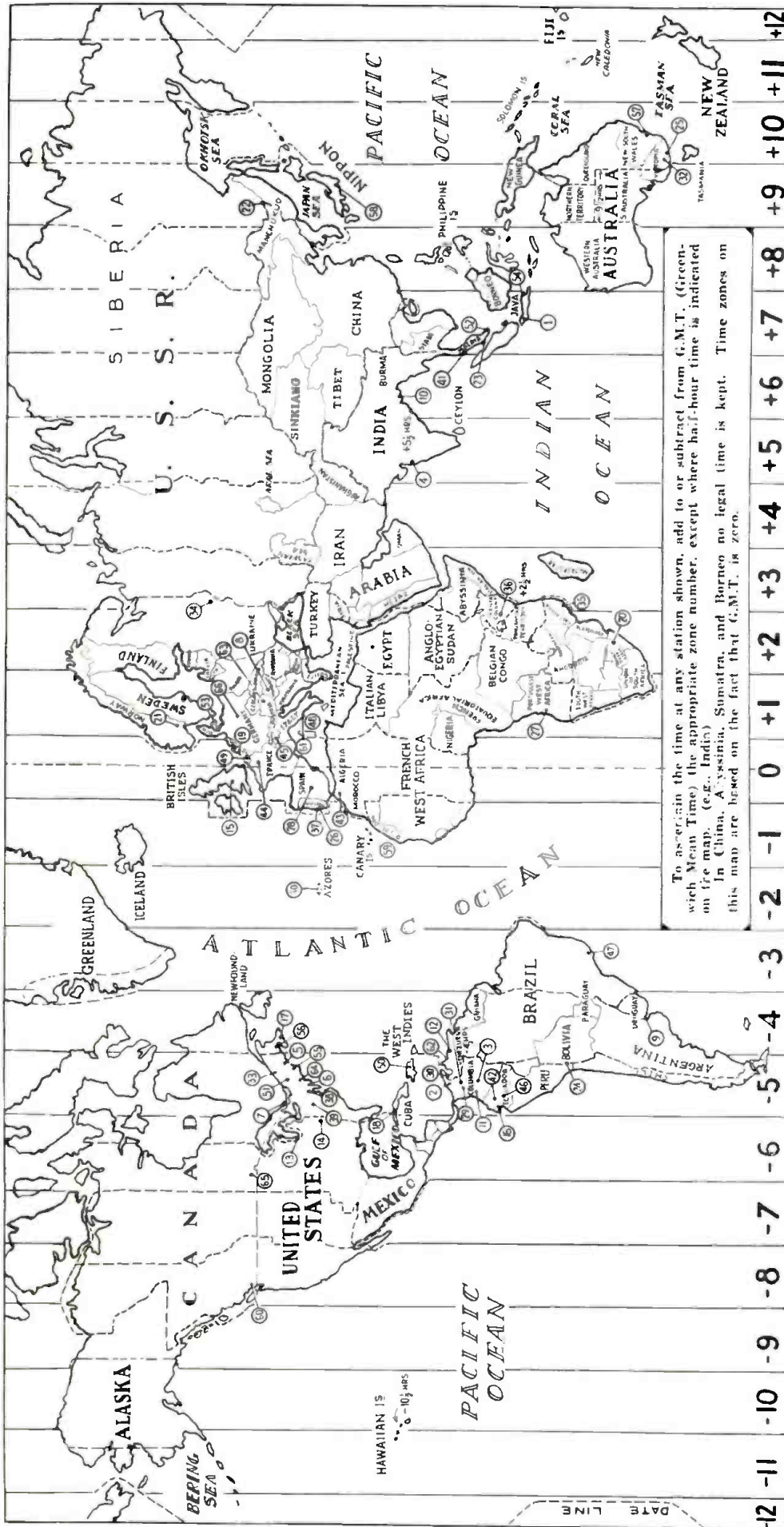

Ref.	Station	Call	m.	Ref.	Station	Call	m.	Ref.	Station	Call	m.	Ref.	Station	Call	m.	Ref.	Station	Call	m.
1	Bandung (Java)	YDA	19.67	26	Lisbon (Portugal)	CSL	18.28	40	Punta Delgada (Azores)	CT2AJ	31.35	65	Winnipeg (Canada)	CJRX	25.8				
2	Bauranquilla (Col.)	HJABB	16.5	27	Lisbon (Portugal)	CT1AA	31.00	41	Quito (Ecuador)	HCIB	31.25	66	Zessen (Germany)	DJA	31.38				
3	Bogota (Colombia, S. Am. Rdn)	HJABBH	14.5	28	Lisbon (Portugal)	CTICT	31.81	42	Rabat (Morocco)	CNR	31.35	67	Zessen (Germany)	DJB	19.71				
4	Bombay (India)	VUB	31.36	29	Lobito (Angola)	CR6AA	41.8	43	Rio de Janeiro (Brazil)	PRF5	31.58	68	Zessen (Germany)	DJC	19.83				
5	Boston (Mass.)	W1XAL	27.15	30	Madrid (Spain)	EAQ	39.13	44	Radio Colonial (France)	TPA4	35.29	69	Zessen (Germany)	DJD	25.19				
6	Bound Brook (N.J.)	W3XAL	39.18	31	Manizales (Colombia)	HJABB	49.11	45	Tenerife Radio Club	VE9CS	49.13	70	Zessen (Germany)	DJE	16.89				
7	Bound Brook (N.J.)	W3XL	45.65	32	Maracaibo (Venezuela)	VY5RMO	31.28	46	Vancouver (Can.)	HVJ	50.26	71	Zessen (Germany)	DJN	31.45				
8	Budapest (Hungary)	W3XL	45.65	33	Medan (Sumatra)	VY5RMO	31.28	47	Valencia (Spain)	YV6RV	46.01	72	Zessen (Germany)	DJO	19.62				
9	Buenos Aires (Argentina)	CRX3	34.28	34	Montevideo (Uruguay)	VK3RE	31.24	48	Vienna (Austria)	OER2	49.4								
10	Calcutta (India)	LRC	22.88	35	Montreal (Quebec)	VE9DR	45.38		Wayne (N.J.)	WZXE	39.02								
11	Call (California)	HJABB	46.15	36	Moscow (U.S.S.R.)	RVE	55.38												
12	Caracas (Venezuela)	HJABB	10.12	37	Moscow (U.S.S.R.)	R7A	55.38												
13	Caracas (Venezuela)	VY3RC	10.12	38	Nairobi (Kenya)	VO7LO	1.42												
14	Chicago (Illinois)	W3XAL	41.88	39	Paris (France)	CTIGO	48.88												
15	Chicago (Illinois)	W3XAL	41.88																
16	Cincinnati (Ohio)	W3XAL	39.33																
17	Davenport (Iowa)	W3XAL	41.55																
18	Davenport (Iowa)	W3XAL	41.55																
19	Davenport (Iowa)	W3XAL	41.55																
20	Davenport (Iowa)	W3XAL	41.55																
21	Davenport (Iowa)	W3XAL	41.55																
22	Davenport (Iowa)	W3XAL	41.55																
23	Davenport (Iowa)	W3XAL	41.55																
24	Davenport (Iowa)	W3XAL	41.55																
25	Davenport (Iowa)	W3XAL	41.55																

# WHAT'S NEW In Short-Wave Apparatus

The short-wave apparatus here shown has been carefully selected for description by the editors after a rigid investigation of its merits

## The Hammarlund "Super-Pro" Receiver

AS explained last month, the "Super-Pro", the latest development of the Hammarlund Laboratories, is a 16 tube superheterodyne consisting of two units—the receiver proper and the power supply.

Part II  
By Donald Lewis

### Receiver

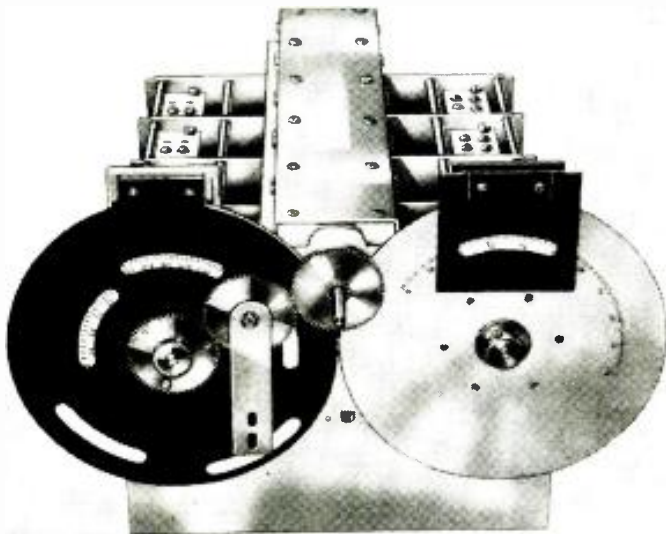

The tuning dials on the new Super-Pro receiver are very cleverly designed so as to provide the easiest possible tuning, combined with the highest accuracy. (No. 557)

We have already discussed the unusual tuning unit with the exclusive new 5-band switch; the tuning coils, and the tubes used.

#### How Band-Spread Is Obtained

Now let us take a look at some of the other unusual components of the tuning system. There is the main tuning condenser, which

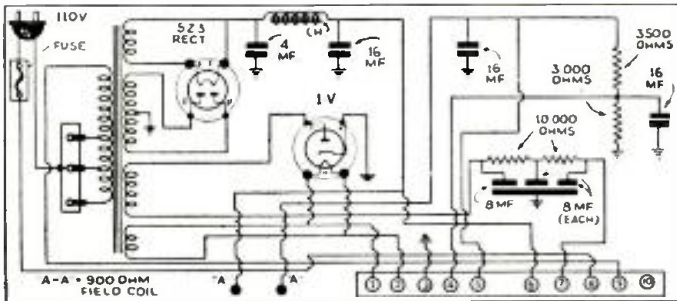

Wiring diagram of the Super-Pro power-supply unit.

has four sections of 180 mmf. each. The rotor plates are of the *midline* type which results in a uniform frequency scale affording a two to one tuning range. The stators are mounted on isolantite blocks, which are in turn secured to the shield partitions which form the frame-work of the tuning unit.

The *band-spread* condenser is mechanically identical with the main tuning condenser. Divided into four main sections, each of these sections has a three-gang condenser with their separate rotors and stators, equivalent therefore to a complete 12-gang condenser. In this way, an appropriate degree of band-spread can be secured in each of the three high-frequency bands. To illustrate, each division of the band-spread dial in the 14.0 to 14.4 mc. amateur band covers approximately 4.5 kilocycles. In the 7 to 7.3 and 3.5 to 4.0 mc. bands, the coverage is approximately 4 and 5 kc. respectively. These coverages afford comfortable non-critical tuning in the high-frequency ranges without an unnecessary amount of dial twisting. On the two lower frequency bands, this condenser is *automatically* cut out of the circuit by the band-changing switch.

#### I.F. Selectivity Continuously Variable

The selectivity of the intermediate frequency amplifier is, as we stated in the first article, continuously variable, by means of a control on the front panel. This control simultaneously varies the coupling between the primaries and secondaries of the first three I.F. transformers. Since both the primary and secondary of each transformer are tuned, this variation of coupling changes the response characteristic from a single sharp peak in the *minimum coupling* position, to a wide double-humped curve in the position of *maximum coupling*. The total range of coupling provided by the panel control is from approximately 1/3 optimum in the narrow position, to about three times optimum in the wide position. The control being continuously variable, any intermediate value between these two extremes is readily obtainable. Therefore, as the selectivity control operates simultaneously on three transformers in cascade, the change in overall selectivity is tremendous. At the same time, such a wide change in coupling also results in a wide variation in gain, except of course when operating on AVC. The three variable coupling I.F. transformers (Continued on page 247)

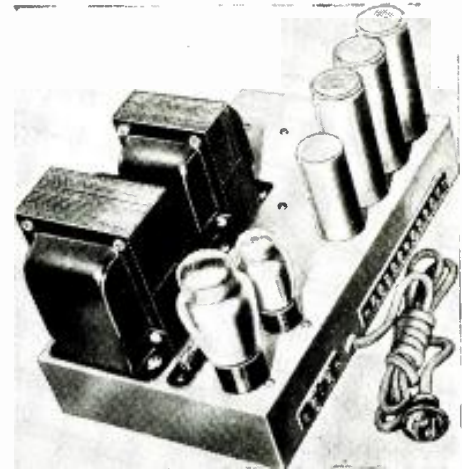

Physical appearance of the power supply unit which is built as a separate unit. It employs two rectifiers—a 5Z3 and a 1V.

### A New Multi-Band Dial

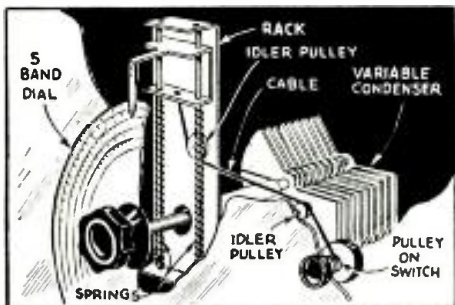

New Multi-hand Tuning Dial. No. 554.

THE accompanying picture shows the new Hallicrafter dial which contains the different graduations or calibrations for five bands. The indicating needle moves across the five bands inscribed on the dial, the position of the indicating needle being controlled by a cable attached to a pulley on the band switch. As the switch is turned from one band to another progressively, the indicator moves up or down as the case may be, and thus points automatically to the particular row of figures on the dial which are to be read by the operator for the particular band being tuned in.

#### External "Mike" Input Transformer—Cable Type

THE new Amperite input transformer of the cable type is designed to operate

low impedance (Continued on page 247)



New External Input Transformer for Coupling Microphone. No. 555.

Names and addresses of manufacturers of apparatus on this and following pages furnished upon receipt of 3-cent stamp; mention No. of article.



# NEW APPARATUS FOR THE "HAM"



New RCA microphone, H54



Universal transformer, H55.

### NEW JUNIOR MIKE, H54

● IN the photograph we see the new RCA Junior velocity microphone intended for use with P. A. systems and for amateur phone use. It has all of the good qualities of the more expensive standard broadcast microphones, and the amateur who desires high quality in his phone signals will be interested in a microphone of this type. It has a frequency range of from 50 to 10,000 cycles with an average operating level of minus 68 D.B.

### UNIVERSAL AUDIO TRANSFORMER, H55

● EXPERIMENTERS will find many uses for this universal audio transformer which is designed for replacement purposes in servicing radio receivers. The frequency response is 30 to 10,000 cycles, and has an over-all turn ratio (primary to secondary) of 1:3. The primary current rating is 10 ma. D.C. and it is designed to couple any single or push-pull triode stage using 10 different types of tubes to any single or push pull stage regardless of the type of tube used. This transformer is truly universal in all respects in so far as audio frequency amplification is concerned. It is a product of the RCA Parts Division.

### GIANT PLUG-IN COIL FORM, H58

● WITH the constant increase in the use of plug-in transmitting inductances, the amateurs should

favorably receive the introduction of this new large Hammarlund plug-in coil form. It is constructed of XP-53 material and the general design, as can be seen in the photograph, is identical to the XP-53 Hammarlund receiving coil form. However, this form has a diameter of 2 1/4 inches and a winding space of 4 inches is available. The form is deeply fluted, providing plenty of air-space around the winding, and they may be easily grooved for holding the wire in place. At the top and bottom edges of the form, there are two holes which are tapped for a 6-32 machine screw. This is presumably for anchoring very heavy wire. These forms are available either with four or five prongs.

### U.H.F. PLUG-IN INDUCTANCE, H56

● READERS who are interested in constructing ultra high frequency receivers and transmitters will be very much interested in the micalex insulated coil assembly. As can be seen in the photograph, one strip contains three miniature jacks while the other contains three plugs. The plugs have a hole in the screw end which will accommodate up to a number 12 wire. This greatly facilitates soldering the coil ends to the plugs and makes a more permanent connection. The micalex strips have an over-all length of 1 3/8" and are 1/2" in width. They are available either with or without the coil, should the experimenter desire to wind his own coils.

(Continued on page 254)

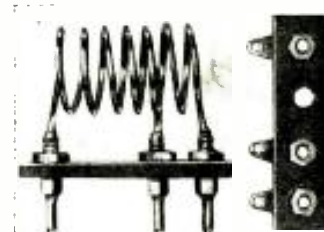

Plug-in U.H.F. inductance, H56.



A complete line of stand-off insulators, H57

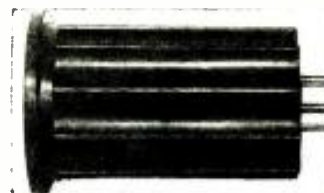

Giant plug-in coil form by Hammarlund, H58.

## 6-Tube A.C. Super-Het Covers Three Bands

● THE accompanying illustration shows a very attractive and efficient 6-tube A.C. super-het of modern "book-case" design. It is the new Lafayette model D-8, and the receiver covers the following wave-length bands: 18-50 meters, 66-187 meters, and of course the B.C. band 200-560 meters.

The size of the cabinet is 19 1/4" long, 9 3/8" high, and 8 3/4" deep, and the cabinet is hand-finished, the wood being a particularly fine grain walnut.

One of the ideas behind the design of this new receiver is that it can be conveniently placed in any ordinary bookcase.

The latest type high-efficiency tubes are used. The tube numbers being: 2-6D6's, 1-75, 1-76, 1-6B5, and 1-80. This receiver has the latest type automatic volume control and the set is equipped with a 4 1/2" airplane type dial, which, in turn, tunes a 3 gang condenser.

The set embodies the two most important features of interest to every radio man—excellent sensitivity and selectivity. The cost of the set is very nominal, considering the high degrees of engineering and workmanship in-



This 6-tube Super-het covers the broadcast as well as two short-wave bands, the 18-50 and the 66-187-meter bands.

corporated in it.

The accompanying diagram shows the simple straight-forward design features and all of the circuit parts and apparatus have been carefully tried out in the laboratory.

(Continued on page 250)

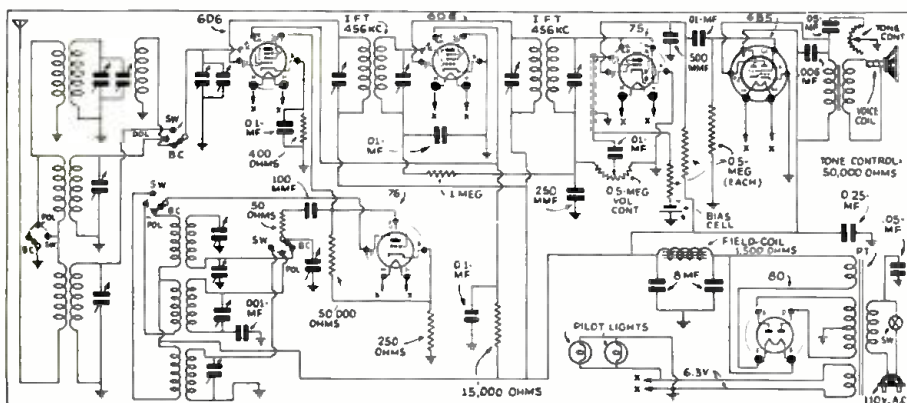

Wiring diagram of the 6-tube A.C. 3-band Super-het. (No. 558)

### Money for Your Ideas!!

● THE editors are looking for good articles describing the detailed construction of improved SHORT-WAVE RECEIVERS suitable for either "Ham" or "Fan" reception, or both. Other short-wave apparatus is also of interest. If you have a new and novel circuit, be sure to send a description and sketch of it to the Editor, and we shall be glad to give you a prompt opinion as to whether or not we would be interested in an article on the subject. All articles accepted and published will be paid for at regular rates.

If you submit an article, finished diagram drawings are not necessary, but the photo should be clear and as large as possible.

# THE RADIO AMATEUR

Conducted by Geo. W. Stuart

## Radio Amateur Course

● IN this lesson we will continue the receiver discussion. In our last lesson we took into consideration the simpler receivers such as the *regenerative* detector, with and without the R.F. (radio frequency) stage. In this lesson, we will cover some of the important points concerning *superheterodynes*. Of course, there is no end to the technicalities involved in designing superheterodynes. However, the average short wave "Fan" and amateur is not interested in detailed technicalities. For instance, the average amateur or "Fan" would not be interested in the technicalities of the converter diagram shown in Fig. 1. It will do him very little good to know the ratios of oscillator output voltage to grid bias and signal in the detector circuit, when in nine cases out of ten he would not be equipped to make the delicate measurements necessary. Therefore, we will cover the standard methods of frequency conversion in so far as practical tube combinations and circuit values are concerned.

### Pentode Power-Detector and Electron-Coupled Oscillator

In Fig. 1, we have the pentode *power-detector* and the pentode *electron-coupled oscillator*. In this circuit the output of the oscillator is coupled to the suppressor grid, the detector. This is known as *suppressor grid injection*. This arrangement works out remarkably well because the tuned circuits are entirely independent of the coupling arrangement. Isolation is accomplished by the *screening* (shielding) of the two tubes. It is in this circuit combination that a minimum of pulling takes place. For instance, the strength of the incoming signals and the adjustment of the detector circuit will have practically no effect upon the oscillator tuning which, of course, results in excellent *stability*. If regeneration is to be used in the first detector circuit in order to improve the *sensitivity* and *selectivity* without adding R.F. preamplifiers, this coupling is the one to use. Of course, without regeneration it would be advisable to employ at least one and preferably two tuned R.F. stages ahead of the pentode detector in order to bring up the sensitivity and reduce image response.

Adding R.F. stages to the front end of a superheterodyne also results in lower-over-all set noises, and generally provides a better signal-to-outside noise ratio.

### Getting the Circuits to "Track"

One of the most difficult problems in a superhet construction is getting the two tuned circuits to track. The oscillator is tuned to a frequency equal to the I.F. frequency higher than the first de-

### TWELFTH LESSON

In this twelfth lesson of our "Ham" Course, popular superheterodyne circuits are discussed.

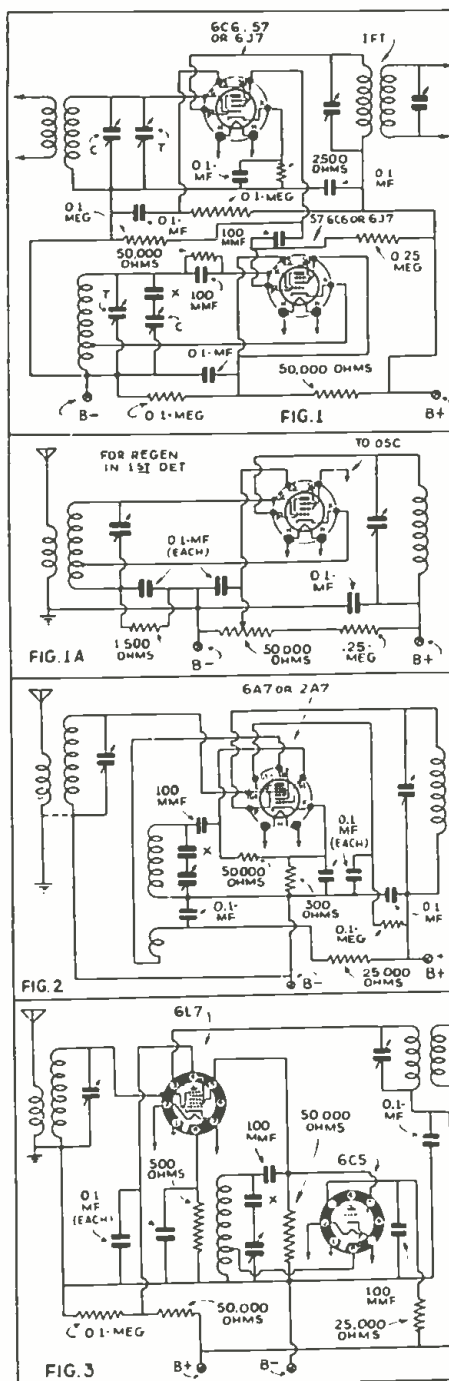

Converter diagrams of the most commonly used types used for superheterodynes.

detector. This means that if we use 465 kc. as the *intermediate frequency* the oscillator will be tuned 465 kc. higher than the frequency of the first detector, which is the signal frequency. This can be accomplished by the use of properly proportioned inductances and the use of padding condensers. In the diagrams we have shown a condenser in series with the oscillator tuning condenser. This condenser is marked "X." Also, we have a condenser across the entire coil. In diagram 1, this is marked "T," and there is one in the detector circuit also. For general use in short-wave receivers where trimmers ("T") 140 mmf. bandsetters are used and mounted on the panel, condenser "X" should have a capacity of between .001 and .002 mf. By properly adjusting the coils of the oscillator circuit nearly perfect, tracking may be maintained between the two stages. We are considering, of course, that the two tuning condensers "C" (usually 35 mmf.) are small in capacity and the two trimmers "T" are fairly large, the usual band-spread and band-setting condenser combination.

The high frequency coils, for instance, tuning around 14 to 15 megacycles will be identical in construction. The padding condenser "X" will easily take care of the difference. However, in coils tuning around 7 megacycles it will be necessary to use slightly less turns on the oscillator coil; of course, if we go lower in frequency or around 3.5 mc., it will be necessary to have a greater difference between the number of turns in the oscillator and detector coils.

### Use of "Dual Purpose" Tube for Detector and Oscillator

In Fig. 1 we have used two separate tubes for converting the frequency. In Fig. 2 we have the 6A7 or 2A7 pentagrid converter. This tube was designed to function both as the first detector and oscillator. Mixing is accomplished electronically within the tube. Although this arrangement is as sensitive as that shown in Fig. 1, experiences have shown that there is considerable reaction between the tuned circuits. Tuning the detector circuit has a noticeable effect upon the oscillator.

The main advantage, of course, is the elimination of the extra tube. However, considering performance, especially on the short waves, one prefers the additional tube.

### A New "Mixer" Tube for Superhets

Tube engineers have been working to improve the conversion efficiency of the superheterodyne, and the result has been the introduction of the new 6L7, which is especially designed for use as a mixer tube. Here we have a tube pro-

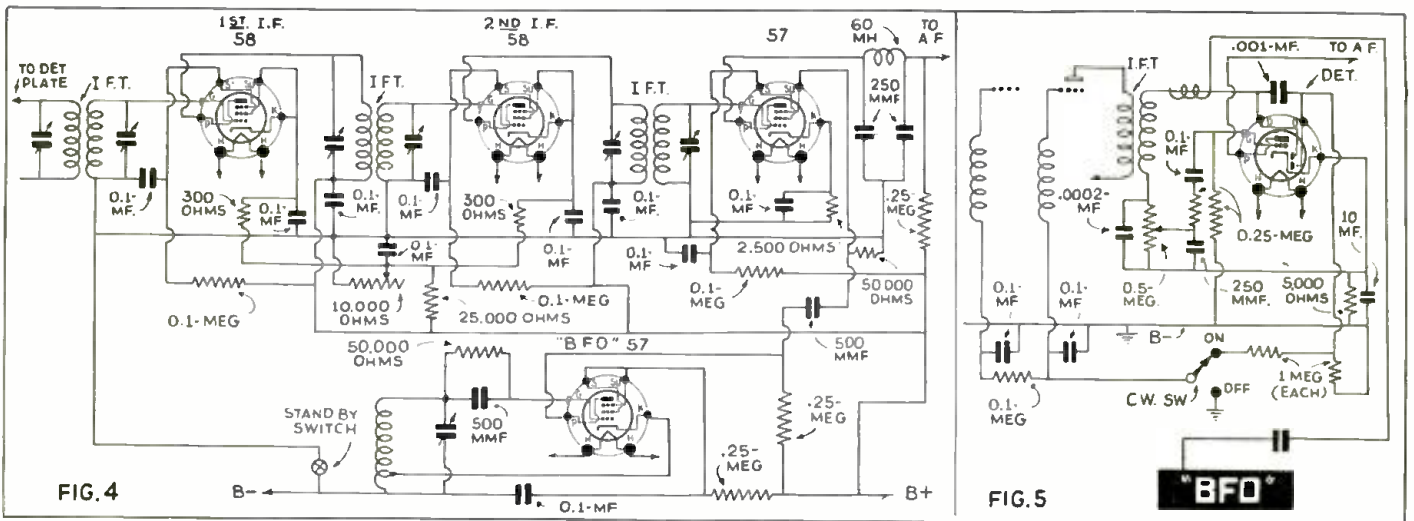

A complete I.F. amplifier with and without A.V.C. The beat oscillator is also shown.

vided with an extra grid solely for the purpose of introducing the oscillator signal into the detector stage. This tube may also be used in a number of other circuit arrangements, but so far it proved the most satisfactory as shown in Fig. 3. This tube provides remarkable conversion efficiency, especially at the higher frequencies and reaction between the two stages has been reduced considerably over other circuits. Of course, both of the diagrams in Fig. 2 and 3, as well as in Fig. 1, require the addition of R.F. stages ahead of the

detector although, as we said before in Fig. 1, *regeneration* may be introduced conveniently in the detector circuit to partly offset the need of tuned R.F. stages.

The intermediate frequency amplifier of the superhet presents no problem at all if care is used in the layout of parts. Most experimenters who have encountered trouble such as due to feedback or regeneration in I.F. amplifiers can blame it, in nearly all cases, to crowding, improper use of by-pass condensers, or carelessness in placing the

wires of the grid and plate circuits.

Beat Oscillator—Its Purpose

In Fig. 4 we have a two-stage I.F. amplifier, the second detector and the beat frequency oscillator. The beat oscillator, of course, is necessary for continuous wave (CW) reception, as we must have some means of bringing about an audible tone from a pure unmodulated carrier. No audio amplifier is shown in this diagram, however, a single 2A5 or 3 watt pentode of any de-

(Continued on page 236)

# A. F. Amplifier for 1 Million Cycles!

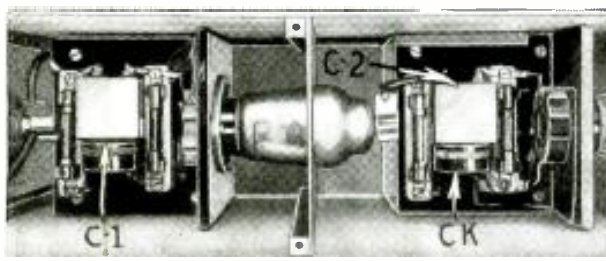

One million cycle A.F. amplifier—C1, cathode condenser; C2, coupling condenser; Ck, choke.

By W. E. S.

The reason that this amplifier design is at present much favored by European radio technicians, lies in the remarkable television progress abroad.

Experience has indicated that the most effective means of obtaining the desired amplifier-qualities is to bring about a decrease in the unwanted capacity between the various elements of the amplifier and its circuits. Since the layout can greatly influence the decrease in the unwanted capacity, much research has been carried on in Europe to study the technical problems of proper layout, and it is to expect that the layout technique developed in Europe in connection with the design of the new A.F. amplifiers, will exert an influence upon the circuit design to be used in connection with future developments in the ultra short wave field.

But this is not all that makes the design of such "broad-range" A.F. amplifiers so interesting to the short-wave amateur. The possibility of amplifying low audio frequencies, as well as radio frequencies, with one amplifier promotes also some hope, that some one—somewhere—will perfect a method for utilizing this kind of amplifier design in the realm of the centimeter and decimeter waves.

How the difficult task of designing such an amplifier was accomplished is indicated by Fig. 1 and 2. Despite the fact that comparatively large coupling condensers had

(Continued on page 250)

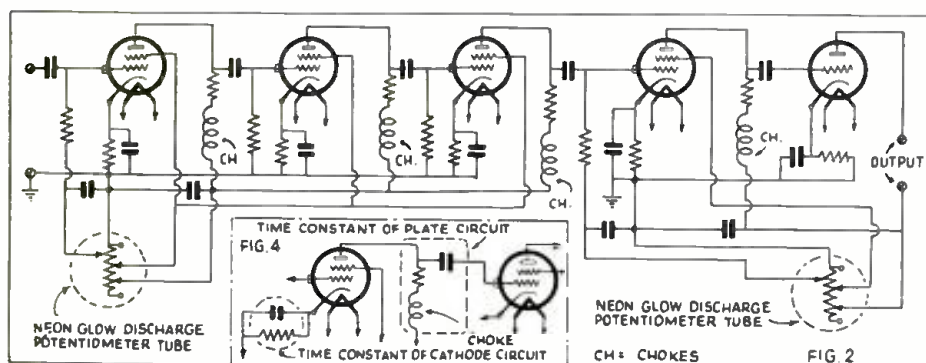

Wiring diagram of the one-million cycle A.F. amplifier.

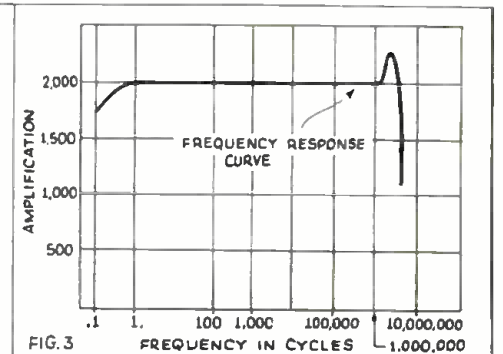

FIG. 3

Here's Your Button

The illustration herewith shows the beautiful design of the "Official" Short Wave League button, which is available to everyone who becomes a member of the Short Wave League.



The requirements for joining the League are explained in a booklet, copies of which will be mailed upon request. The button measures 3/4 inch in diameter and is inlaid in enamel—3 colors—red, white, and blue.

Please note that you can order your button AT ONCE—SHORT WAVE LEAGUE supplies it at cost, the price, including the mailing, being 35 cents. A solid gold button is furnished for \$2.00 prepaid. Address all communications to SHORT WAVE LEAGUE, 99-101 Hudson St., New York.

HONORARY MEMBERS

- Dr. Lec de Forest
  - John L. Reinartz
  - D. E. Replogle
  - Hollis Baird
  - E. T. Somerset
  - Baron Manfred von Ardenne
  - Hugo Gernsback
- Executive Secretary*



Report from Freeport, Pa.

● A LITTLE careful tuning on the 20-meter amateur phone band any night from 5:00 p.m. to 10:00 p.m. will bring in loads of foreign "Hams".

- OA4AA, in Peru, on about 14.30 meg.
  - F8LZ, in France, on 14.07 meg.
  - F3CP, in France, on 14.35 meg.
  - EA8AL, in Africa, on 14.27.
- Ireland is represented by station EI2J at Dublin on 14.13 meg.

The VK "hams" have been coming in up until 8:00 a.m., E.S.T.

Now that the baseball season is in full swing, you may hear the reports of the days' games in Japan, over station JVN on 10.66 meg. at 4:00 to 5:00 p.m.

2RO, Rome, Italy, is testing on 11.81 meg. in the afternoons and by the time this is read they may be broadcasting the afternoon programs on that wave.

HAS3, Budapest, Hungary, on 15.37 meg., 9:00 to 10:00 a.m. Sundays has not been heard here for about a month.

TFJ, Iceland phones England 9:00 to 11:00 a.m.

ANGELO CENTANINO,  
Box 516,  
Freeport, Pa.

Brecksville, Ohio, O.L.P. Short Wave Log

- 4/23—TIEP—6,710 kc.—8:00 p.m., Costa Rica, C. A. Loud, some noise.
- 4/23—W2XGB—6,425—8:10 p.m., Hicksville, L.I. Test program, very loud.
- 4/24—GSD—11,750—10:50 p.m., England. Fair.
- 4/25—GSP—15,310—7:30 p.m., England. Loud and steady.
- 4/25—GSD—11,750—7:35 p.m., England. Very loud and clear.
- 4/25—DJD—11,770—7:40 p.m., Germany. Very, very loud.
- 4/25—EAQ—9,860—7:45 p.m., Spain. Loud, but distorted.
- 4/25—GSC—9,580—7:50 p.m., England. Very loud, but noisy.
- 4/27—GSP—15,310—7:00 p.m., England. Very loud and clear.
- 4/27—GSD—11,750—7:05 p.m., England. Loud. Not as loud as GSP.
- 4/27—DJD—11,770—7:10 p.m., Germany. Very loud.
- 4/27—CEC—10,670—7:15 p.m., Chile. Very loud, some noise.
- 4/27—2RO—9,635—7:20 p.m., Italy. Fair.
- 5/3—DJD—11,770—10:20 p.m., Germany. Very loud and clear.
- 5/3—GSD—11,750—10:30 p.m., England. Exceptionally loud.
- 5/3—GSC—9,580—10:35 p.m., England. Very loud and clear.
- 5/12—VK3ME—9,510—6:00 a.m., Australia. Loud, steady and clear.
- 5/12—JVM—10,740—6:15 a.m., Japan. Loud and clear.
- 5/13—DJD—11,770—10:15 p.m., Germany. Very loud.

SHORT WAVE SCOUT News

- 5/13—GSD—11,750—10:20 p.m., England. Very loud.
  - 5/13—CJRX—11,720—10:25 p.m., Canada. Very, very loud.
  - 5/13—GSC—9,580—10:30 p.m., England. Very loud and clear.
  - 5/13—COCH—9,428—10:40 p.m., Cuba. Clear but weak.
- Time given is E.S.T. Freq. in kilocycles.  
EDWARD M. HEISER,  
Route 2, Box 124.

Official Listening Post Report of F. W. Hartman, South Amboy, N.J.  
● DURING the past month only 75 stations

were heard; many of them were new ones, conditions were Fair to Good. Many Foreign Amateurs were heard on the 20 meter band. I want to thank the foreign amateurs for so kindly answering my cards. The airship *Hindenburg* was heard on its trip to the U.S. on May 8th, on 10,290 Kc., working New York. The following is a list of the more important stations heard: (Eastern Standard Time used throughout.)

- The Voice of Colombia, Apartado 2665, Bogota, Colombia, on about 6,120 Kc. is heard until about 9:30 p.m., with good strength.
- H13C—La Ramona, D.R.—6,900 Kc. heard many times with excellent volume.
- EAQ—Madrid, Spain—heard broadcasting a special program to New York on April 26th on about 15 meters or 19 mc. with very good strength from 12:25 to 1:15 p.m.
- CEC—Santiago, Chile, S. A.—10,670 Kc., heard many times with good strength.
- H19B—Santiago, D. R.—6,050 Kc., heard several times, fair to good.
- COKG—Santiago, Cuba—6,155 Kc., heard "good" many times.

DJR—Berlin, Germany—15,340 Kc. Heard on May 15th with a special program for New York, with very good volume at 1:20 p.m.

HIH—San Pedro, D.R.—6,814 Kc. Heard many times with good volume.

H18Q—Ciudad Trujillo, D.R.—6,240 Kc. Is heard until 9 p.m., with good volume, and requesting reports. It will verify reports.

HRD—La Voz de Atlantico, La Ceibe, Honduras—6,200 Kc. Heard until 11 p.m.

HJM—La Voz Del Pacifico, Buenaventura, Colombia is on 8 to 11 p.m., daily on 9,510 Kc.

TGW—Radiodifusora Nacional, Guatemala City, Guatemala, is on 9,450 Kc. from 9 to 10 p.m., and 11 to 1 a.m., and Saturdays from 11 p.m. to 7 a.m. on Sunday.

OER2—Osterr. Radioverkehrs A. G., Wein, I., Johannesgasse 4b., Austria, is on 6,072 Kc. on Mondays, Tuesdays, Wednesdays, Thursdays and Fridays from 9 a.m. to 5 p.m., on Saturdays until 6 p.m.

Regarding HRN, I have sent two letters and a card to them requesting a Veri, but have yet to receive one. I do not think that HRN answers reports.

Veris received: HJU, TGW, OER2, COCO, GBB, PHI for 11,730 Kc.

I answer all mail.

FLETCHER W. HARTMAN,  
365 John Street,  
South Amboy, New Jersey.

Short Wave Scout Report from Parma, Ohio

● THE following is my report for this past (Continued on page 254)



**Short Wave League**

At a Directors Meeting held in New York City, New York in the United States of America, the Short Wave League has elected

**John F. Müller**

a member of this League.

In Witness whereof, this certificate has been officially signed and presented to the above

*H. Wainfield Secor*  
Club Secretary

This is the handsome certificate that is presented FREE to all members of the SHORT WAVE LEAGUE. The full size is 7 1/4" x 9 1/2". See page 252 how to obtain certificate.



# World S-W Station List

## Complete List of Broadcast, and Telephone Stations

All the stations in this list use telephone transmission of some kind. Note: Stations marked with a star ★ are the most active and easily heard stations and transmit at fairly regular times. Please write to us about any new sta-

tions or other important data that you learn through announcements over the air or correspondence with the stations. Stations are classified as follows: C—Commercial phone. B—Broadcast service. X—Experimental transmissions.

## Around-the-Clock Listening Guide

It is a good idea to follow a general schedule as far as wavelength in relation to the time of the day is concerned. The observance of these simple rules will save time.

From daybreak till 7 p.m. and particularly

during bright daylight, listen between 13 and 19 meters (21540 to 15800 kc.)

To the east of the listener, from about 4 p.m.-5 a.m., the 19-35 meter will be found very productive. To the west of the listener this same

band is generally found best from about 12 m. until 7 a.m. (After dark, results above 35 meters are usually much better than during daylight.) These general rules hold for any location in the Northern Hemisphere.

## Short-Wave Broadcasting, Experimental and Commercial Radiophone Stations

NOTE: To convert kc. to megacycles (mc.) shift decimal point 3 places to left: Thus, read 21540 kc. as 21.540 mc.

<p><b>31600 kc. W2XDU</b> -B-X- 9.494 meters ATLANTIC BROADCASTING CO., 485 MADISON AVE., N.Y.C. Relays WABC daily 5-10 p.m., Sat., Sun. 12:30-5, 6-9 p.m.</p> <p><b>31600 kc. W8XAI</b> -B-X- 9.494 meters STROMBERG CARLSON CO. ROCHESTER, N.Y. Relays WHAM daily 7:30 a.m.- 12:05 a.m.</p> <p><b>31600 kc. W8XWJ</b> -B-X- 9.494 meters DETROIT, MICH. 6:15 a.m.-12:30 p.m., 2-5, 7-10 p.m.</p> <p><b>21540 kc. W8XK</b> -B- 13.03 meters WESTINGHOUSE ELECTRIC PITTSBURGH, PA. 6-9 a.m.; relays KDKA</p> <p><b>21530 kc. GSJ</b> -B- 13.93 meters DAVENTRY B.B.C., BROADCASTING HOUSE, LONDON, ENGLAND</p> <p><b>21520 kc. W2XE</b> -B- 13.94 meters ATLANTIC BROADCASTING CORP. 485 Madison Ave., N.Y.C. Relays WABC 6:30 a.m.-12 n.</p> <p><b>21470 kc. ★GSH</b> 13.97 meters DAVENTRY B.B.C., BROADCASTING HOUSE, LONDON, ENGLAND 6-8:45, 9-10:30 a.m.</p> <p><b>21420 kc. WKK</b> -C- 14.01 meters AMER. TEL. &amp; TEL. CO., LAWRENCEVILLE, N. J. Calls S. America 8 a.m.-4 p.m.</p> <p><b>21080 kc. PSA</b> -C- 14.23 meters RIO DE JANEIRO, BRAZIL Works WKK Daytime</p> <p><b>21060 kc. WKA</b> -C- 14.25 meters LAWRENCEVILLE, N. J. Calls England noon</p> <p><b>21020 kc. LSN6</b> -C- 14.27 meters HURLINGHAM, ARG. Calls N. Y. C. 8 a.m.-8 p.m.</p> <p><b>20860 kc. EHY-EDM</b> -C- 14.38 meters MADRID, SPAIN Works S. America, mornings.</p> <p><b>20700 kc. LSY</b> -C- 14.49 meters MONTE GRANDE ARGENTINA Tests Irregularly</p> <p><b>20380 kc. GAA</b> -C- 14.72 meters RUGBY, ENGLAND Calls Argentina, Brazil, mornings</p> <p><b>20040 kc. OPL</b> -C- 14.97 meters LEOPOLDVILLE, BELGIAN CONGO Works with ORG in morning</p>	<p><b>20020 kc. DHO</b> -C- 14.99 meters NAUEN, GERMANY Works S. America, mornings</p> <p><b>19900 kc. LSG</b> -C- 15.08 meters MONTE GRANDE, ARGENTINA Tests Irregularly, daytime</p> <p><b>19820 kc. WKN</b> -C- 15.14 meters LAWRENCEVILLE, N. J. Calls England, daytime</p> <p><b>19680 kc. CEC</b> -C- 15.24 meters SANTIAGO, CHILE Works Buenos Aires and Colom- bia daytime</p> <p><b>19650 kc. LSN5</b> -C- 15.27 meters HURLINGHAM, ARGENTINA Calls Europe, daytime</p> <p><b>19600 kc. LSF</b> -C- 15.31 meters MONTE GRANDE, ARGENTINA Tests Irregularly, daytime</p> <p><b>19480 kc. GAD</b> -C- 15.4 meters RUGBY, ENGLAND Works with Kenya, Africa, early morning</p> <p><b>19355 kc. FTM</b> -C- 15.50 meters ST. ASSISE, FRANCE Calls Argentine, mornings</p> <p><b>19345 kc. PMA</b> -B-C- 15.51 meters BANDONG, JAVA Calls Holland early a.m. Broadcasts Tues., Thur., Sat., 10:00-10:30 a.m. Irregular</p> <p><b>19260 kc. PPU</b> -C- 15.58 meters RIO DE JANEIRO, BRAZIL Works with Franco mornings</p> <p><b>19220 kc. WKF</b> -C- 15.60 meters LAWRENCEVILLE, N. J. Calls England, daytime</p> <p><b>19200 kc. ORG</b> -C- 15.62 meters RUYSSSELEDE, BELGIUM Works with OPL mornings</p> <p><b>19160 kc. GAP</b> -C- 15.66 meters RUGBY, ENGLAND Calls Australia, early a.m.</p> <p><b>18970 kc. GAQ</b> -C- 15.81 meters RUGBY, ENGLAND Calls S. Africa, mornings</p> <p><b>18890 kc. ZSS</b> -C- 15.88 meters KLIPHEUVEL, S. AFRICA Works Rugby 6:30 a.m.-12 n</p> <p><b>18830 kc. PLE</b> -C- 15.93 meters BANDONG, JAVA Calls Holland, early a. m.</p> <p><b>18680 kc. OCI</b> -C- 16.06 meters LIMA, PERU Works various S.A. stations daytime</p>	<p><b>18620 kc. GAU</b> -C- 16.11 meters RUGBY, ENGLAND Calls N. Y., daytime</p> <p><b>18345 kc. FZS</b> -C- 16.35 meters SAIGON, INDO-CHINA Phones Paris, early morning</p> <p><b>18340 kc. WLA</b> -C- 16.36 meters LAWRENCEVILLE, N. J. Calls England, daytime</p> <p><b>18310 kc. GAS</b> -C- 16.38 meters RUGBY, ENGLAND Calls N. Y., daytime</p> <p><b>18299 kc. YVR</b> -C- 16.39 meters MARACAY, VENEZUELA Works Germany, mornings</p> <p><b>18270 kc. ETA</b> -C- 16.42 meters CHIEF ENGINEER P. O. Box 283, ADDIS ABABA, ETHIOPIA Irregularly</p> <p><b>18250 kc. FTO</b> -C- 16.43 meters ST. ASSISE, FRANCE Calls S. America, daytime</p> <p><b>18200 kc. GAW</b> -C- 16.46 meters RUGBY, ENGLAND Calls N. Y., daytime</p> <p><b>18135 kc. PMC</b> -C- 16.54 meters BANDONG, JAVA Calls Holland, early a. m.</p> <p><b>18115 kc. LSY3</b> -C- 16.56 meters MONTE GRANDE, ARGENTINA Tests Irregularly</p> <p><b>18040 kc. GAB</b> -C- 16.63 meters RUGBY, ENGLAND Calls Canada, morn. and early aftn.</p> <p><b>17810 kc. PCV</b> -C- 16.84 meters KOOTWIJK, HOLLAND Calls Java, 6-9 a. m.</p> <p><b>17790 kc. ★GSG</b> -B- 16.86 meters DAVENTRY B.B.C., BROADCASTING HOUSE, LONDON, ENGLAND 6-8:45 a.m., 9 a.m.-12 n., 3:40-5:45 p.m.</p> <p><b>17780 kc. ★W3XAL</b> -B- 16.87 meters NATIONAL BROAD. CO. BOUND BROOK, N. J. Relays WJZ, Daily exc. Sun. 8 a.m.-4 p.m.</p> <p><b>17775 kc. ★PHI</b> -B- 16.88 meters HUIZEN, HOLLAND 7:30-9:30 a.m. daily except Tue. and Wed. 1-2 p.m. Sun.</p> <p><b>17760 kc. ★W2XE</b> -B- 16.89 meters ATLANTIC BROADCASTING CORP. 485 Madison Ave., N.Y.C.</p>	<p><b>17760 kc. DJE</b> -B- 16.89 meters BROADCASTING HOUSE BERLIN, GERMANY 8:05-11 a.m.</p> <p><b>17760 kc. IAC</b> -C- 16.89 meters PISA, ITALY Calls ships, 6:30-7:30 a. m.</p> <p><b>17741 kc. HSP</b> -C- 16.91 meters BANGKOK, SIAM Works Germany 4-7 a.m.</p> <p><b>17650 kc. XGM</b> -C- 17 meters SHANGHAI, CHINA Works London 7-9 a.m.</p> <p><b>17520 kc. DFB</b> -C- 17.12 meters NAUEN, GERMANY Works S. America near 9:15 a.m.</p> <p><b>17510 kc. VWY2</b> -C- 17.13 meters KIRKEE, INDIA Works Rugby 2-7 a.m.</p> <p><b>17310 kc. W3XL</b> -X- 17.33 meters NATIONAL BROAD. CO. BOUND BROOK, N. J. Tests Irregularly</p> <p><b>17120 kc. WOO</b> -C- 17.52 meters A. T. &amp; T. CO., OCEAN GATE, N. J. Calls ships</p> <p><b>17080 kc. GBC</b> -C- 17.56 meters RUGBY, ENGLAND Calls Ships</p> <p><b>16270 kc. WLK</b> -C- 18.44 meters LAWRENCEVILLE, N. J. Phones Arg., Braz., Peru, daytime</p> <p><b>16270 kc. WOG</b> -C- 18.44 meters OCEAN GATE, N. J. Calls England, morning and early afternoon</p> <p><b>16240 kc. KTO</b> -C- 18.47 meters MANILA, P. I. Calls Cal., Tokio and ships 8-11:30 a.m.</p> <p><b>16233 kc. FZR3</b> -C- 18.48 meters SAIGON, INDO-CHINA Calls Paris and Pacific Isles</p> <p><b>15880 kc. FTK</b> -C- 18.90 meters ST. ASSISE, FRANCE Phones Saigon, morning</p> <p><b>15865 kc. CEC</b> -C- 18.91 meters SANTIAGO, CHILE Works other S.A. stations afternoons</p> <p><b>15810 kc. LSL</b> -C- 18.98 meters HURLINGHAM, ARGENTINA Calls Brazil and Europe, daytime</p> <p><b>15760 kc. JYT</b> -X- 19.04 meters KEMIKWA-CHO, CHIBA- KEN, JAPAN Irregular in late afternoon and early morning</p>	<p><b>15660 kc. JVE</b> -C- 19.16 meters NAZAKI, JAPAN Phones Java 3-5 a.m.</p> <p><b>15620 kc. JVF</b> -C- 19.2 meters NAZAKI, JAPAN Phones U.S., 5 a.m.- &amp; 4 p.m.</p> <p><b>15460 kc. KKR</b> -C- 19.4 meters RCA COMMUNICATIONS, BOLINAS, CAL. Tests Irregularly</p> <p><b>15415 kc. KWO</b> -C- 19.46 meters DIXON, CAL. Phones Hawaii 2-7 p.m.</p> <p><b>15370 kc. ★HAS3</b> -B- 19.52 meters BUDAPEST, HUNGARY Broadcasts Sundays, 9-10 a.m.</p> <p><b>15360 kc. DZG</b> -X, C- 19.53 meters REICHSPOSTSTENZALAMT, ZEESEN, GERMANY Works with Africa and tests ir- regularly</p> <p><b>15355 kc. KWU</b> -C- 19.53 meters DIXON, CAL. Phones Pacific Isles and Japan</p> <p><b>15340 kc. DJR</b> -B-X- 19.56 meters BROADCASTING HOUSE, BERLIN, GERMANY 1:30-3:30 a.m.</p> <p><b>15330 kc. ★W2XAD</b> -B- 19.56 meters GENERAL ELECTRIC CO. SCHENECTADY, N. Y. Relays WGY 10 a.m.-2 p.m.</p> <p><b>15310 kc. ★GSP</b> -B- 19.6 meters DAVENTRY B.B.C., BROADCASTING HOUSE, LONDON, ENGLAND 6-8 p.m.</p> <p><b>15290 kc. LRU</b> -B- 19.62 meters "EL MUNDO" BUENOS AIRES, ARGEN- TINA, S. A. Broadcasts 7-7:30, 11-11:30 a.m. and around 4 p.m.</p> <p><b>15280 kc. DJQ</b> -B- 19.63 meters BROADCASTING HOUSE BERLIN, GERMANY 12:30-7 a.m.</p> <p><b>15270 kc. ★W2XE</b> -B- 19.65 meters ATLANTIC BROADCASTING CORP. 485 Madison Ave., N.Y.C. WABC daily, 12 n.-4 p.m.</p> <p><b>15260 kc. GSI</b> -B- 19.66 meters DAVENTRY, B.B.C., BROADCASTING HOUSE, LONDON, ENGLAND 12:15-3:30 p.m.</p> <p><b>15252 kc. RIM</b> -C- 19.67 meters TACHKENT, U.S.S.R., Phones RKI near 7 a.m.</p> <p><b>15250 kc. W1XAL</b> -B- 19.67 meters BOSTON, MASS. Irregular, in morning</p>
--	---	---	---	---

(All Schedules Eastern Standard Time)

**15245 kc. ★TPA2**  
-B- 19.88 meters  
"RADIO COLONIAL"  
PARIS, FRANCE  
Service de la Radiodiffusion  
98, bis, Blvd. Haussmann  
4:55-10 a.m.

**15220 kc. ★PCJ**  
-B- 19.71 meters  
N.V. PHILIPS' RADIO  
EINDHOVEN, HOLLAND  
Tues. 4-6 a.m.  
Wed. 7-11 a.m.  
Sun. 6:30-7:30 a.m.

**15210 kc. ★W8XK**  
-B- 19.72 meters  
WESTINGHOUSE ELECTRIC  
& MFG. CO.  
PITTSBURGH, PA.  
9 a.m.-7 p.m.  
Relays KDKA

**15200 kc. ★DJB**  
-B- 19.74 meters  
BROADCASTING HOUSE  
BERLIN, GERMANY  
3:50-11 a.m., 4:50-10:55 p.m.  
Sun also 11 a.m.-12 n.

**15180 kc. ★GSO**  
-B- 19.76 meters  
DAVENTRY  
B.B.C., BROADCASTING  
HOUSE, LONDON, ENGLAND  
3:40-5:45 p.m.

**15140 kc. ★GSF**  
-B- 19.82 meters  
DAVENTRY  
B.B.C., BROADCASTING  
HOUSE, LONDON, ENGLAND  
9 a.m.-12 n., 3:40-5:45, 6-8 p.m.

**15120 kc. HVJ**  
-B- 19.83 meters  
VATICAN CITY  
ROME, ITALY  
10:50 to 10:45 a.m., except  
Sunday  
Sat. 10-10:45 a.m.

**15110 kc. DJL**  
-B.X- 19.85 meters  
BROADCASTING HOUSE,  
BERLIN, GERMANY  
5:45-7:30 a.m.

**15090 kc. RKI**  
-C- 19.88 meters  
MOSCOW, U.S.S.R.  
Phones Tashkent near 7 a.m.  
and relays RNE on Sundays  
10-11 a.m.

**15070 kc. PSD**  
-C- 19.91 meters  
RIO DE JANEIRO, BRAZIL  
Calle N.Y., Buenos Aires and  
Europe, daytime

**15055 kc. WNC**  
-C- 19.82 meters  
HIALEAH, FLORIDA  
Calls Central America, daytime

**14980 kc. KAY**  
-B- 20.05 meters  
MANILA, U.P.  
Phones Pacific Isles

**14970 kc. LZA**  
-B.C- 20.04 meters  
SOFIA, BULGARIA  
Tests irregularly till 11:30 a.m.  
on Sundays

**14960 kc. PSF**  
-C- 20.43 meters  
RIO DE JANEIRO, BRAZIL  
Works with Buenos Aires  
daytime

**14950 kc. HJB**  
-C- 20.07 meters  
BOGOTA, COL.  
Calls WNC, daytime

**14940 kc. HII**  
-C- 20.08 meters  
CIUDAD TRUJILLO, D.R.  
Phones WNC daytime

**14940 kc. HJA3**  
-C- 20.08 meters  
BARRANQUILLA, COL.  
Works WNC daytime

**14845 kc. OCJ2**  
-C- 20.21 meters  
LIMA, PERU  
Works other S.A. stations  
daytime

**14653 kc. GBL**  
-C- 20.47 meters  
RUGBY, ENGLAND  
Works Jvh 1-7 a.m.

**14640 kc. TYF**  
-C- 20.49 meters  
PARIS, FRANCE  
Works Saigon and Cairo 3-7  
a.m., 12 n.-2:30 p.m.

**14600 kc. JVH**  
-B.C- 20.55 meters  
NAZAKI, JAPAN  
Phones Europe 4-8 a.m.  
Broadcasts 12 m.-1 a.m.  
Tues. and Fri. 2-3 p.m.  
Mon. and Thurs. 4-5 p.m.

**14590 kc. WMN**  
-C- 20.56 meters  
LAWRENCEVILLE, N. J.  
Phones England  
morning and afternoon

**14535 kc. HBJ**  
-B- 20.64 meters  
RADIO NATIONS,  
GENEVA, SWITZERLAND  
Broadcasts irregularly

**14530 kc. LSN**  
-C- 20.85 meters  
HURLINGHAM, ARGENTINA  
Calls N.Y.C. afternoons

**14500 kc. LSM2**  
-C- 20.89 meters  
HURLINGHAM, ARGENTINA  
Calls Rio and Europe daytime

**14485 kc. TIR**  
-C- 20.71 meters  
CARTAGO, COSTA RICA  
Phones Con. Amor. & U.S.A.  
Daytime

**14485 kc. HPF**  
-C- 20.71 meters  
PANAMA CITY, PAN.  
Phones WNC daytime

**14485 kc. TGF**  
-C- 20.71 meters  
GUATEMALA CITY, QUAT.  
Phones WNC daytime

**14485 kc. YNA**  
-C- 20.71 meters  
MANAGUA, NICARAGUA  
Phones WNC daytime

**14485 kc. HRL5**  
-C- 20.71 meters  
NACADOME, HONDURAS  
Works WNC daytime

**14485 kc. HRF**  
-C- 20.71 meters  
TEGUCIGALPA, HONDURAS  
Works WNC daytime

**14470 kc. WMF**  
-C- 20.73 meters  
LAWRENCEVILLE, N. J.  
Phones England  
morning and afternoon

**14460 kc. DZH**  
-C.X- 20.75 meters  
REICHSPOSTZENSTRALAMT,  
ZEESEN, GERMANY  
Works on telephony and tests  
3:45-5:45 a.m.

**14440 kc. GBW**  
-C- 20.76 meters  
RUGBY, ENGLAND  
Calls U.S.A., afternoon

**13990 kc. GBA**  
-C- 21.44 meters  
RUGBY, ENGLAND  
Calls  
Buenos Aires, late afternoon

**13820 kc. SUZ**  
-C- 21.71 meters  
ABOU ZABAL, EGYPT  
Works with Europe 11 a.m.-  
2 p.m.

**13690 kc. KKZ**  
-C- 21.91 meters  
RCA COMMUNICATIONS  
BOLINAS, CAL.  
Tests irregularly

**13635 kc. SPW**  
-B- 22 meters  
WARSAW, POLAND  
Mon., Wed., Fri. 11:30 a.m.-  
12:30 p.m.  
Irregular at other times

**13610 kc. JYK**  
-C- 22.04 meters  
KEMIKAWA-CHO, CHIBA-  
KEN, JAPAN  
Phones California till 11 p. m.

**13585 kc. GBB**  
-C- 22.08 meters  
RUGBY, ENGLAND  
Calls  
Egypt & Canada, afternoons

**13415 kc. GCJ**  
-C- 22.96 meters  
RUGBY, ENGLAND  
Calls Japan & China early  
morning

**13390 kc. WMA**  
-C- 22.40 meters  
LAWRENCEVILLE, N. J.  
Phones England  
morning and afternoon

**13380 kc. IDU**  
-C- 22.42 meters  
ASMARA, ERITREA, AFRICA  
Works with Rome daytime

**13345 kc. YVQ**  
-C- 22.48 meters  
MARACAY, VEZUELA  
Calls Hialeah daytime

**13285 kc. CGA3**  
-C- 22.58 meters  
DRUMMONDVILLE, QUE.,  
CAN.  
Works London and Ships  
afternoons

**13075 kc. VPD**  
-X- 22.94 meters  
SUVA, FIJI ISLANDS  
Daily ex. Sun. 12:30-1:30 a.m.

**12840 kc. WOO**  
-C- 23.36 meters  
OCEAN GATE, N. J.  
Calls ships

**12825 kc. CNR**  
-B.C- 23.39 meters  
DIRECTOR GENERAL  
Telegraph and Telephone  
Stations, Rabat, Morocco  
Broadcasts, Sunday, 7:30-9 a. m.

**12800 kc. IAC**  
-C- 23.45 meters  
PISA, ITALY  
Calls Italian ships, morning

**12780 kc. GBC**  
-C- 23.47 meters  
RUGBY, ENGLAND  
Calls ships

**12396 kc. CT1G0**  
-B- 24.2 meters  
PAREDE, PORTUGAL  
Sun. 10-11:30 a.m., Tues.,  
Thur., Fri. 1:00-2:15 p.m.

**12325 kc. DAF**  
-C- 24.34 meters  
NORDDIECH, GERMANY  
Works German ships daytime

**12290 kc. GBU**  
-C- 24.41 meters  
RUGBY, ENGLAND  
Calls N.Y.C., afternoon

**12250 kc. TYB**  
-C- 24.49 meters  
PARIS, FRANCE  
Irregular

**12235 kc. TFJ**  
-B.C- 24.52 meters  
REYKJAVIK, ICELAND  
Phones England mornings,  
Broadcasts Sun. 1:40-2 p.m.

**12215 kc. TYA**  
-C- 24.56 meters  
PARIS, FRANCE  
Works French Ships in morning  
and afternoon

**12150 kc. GBS**  
-C- 24.69 meters  
RUGBY, ENGLAND  
Calls N.Y.C., afternoon

**12130 kc. DZE**  
-C.X- 24.73 meters  
REICHSPOSTZENSTRALAMT,  
ZEESEN, GERMANY  
Works phone and tests  
irregularly

**12060 kc. PDV**  
-C- 24.88 meters  
KOOTWIJK, HOLLAND  
Tests irregularly

**12000 kc. RNE**  
-B- 25 meters  
MOSCOW, U. S. S. R.  
Sun. 6-9, 10-11 a.m., 12:30-  
6 p.m., 9-10 p.m.  
Wed. 6-7 a.m.  
Daily 12:30-6 p.m.

**11991 kc. FZS2**  
-C- 25.02 meters  
SAIGON, IND-CHINA  
Phones Paris, morning

**11955 kc. ETB**  
-C- 25.09 meters  
ADDIS ABABA, ETHIOPIA  
See 18270 kc.

**11950 kc. KKQ**  
-X- 25.10 meters  
BOLINAS, CALIF.  
Tests, irregularly, evenings

**11940 kc. FTA**  
-C- 25.13 meters  
STE. ASSISE, FRANCE  
Phones CNR morning,  
Hurlingham, Arao., nights

**11880 kc. ★TPA3**  
-B- 25.23 meters  
"RADIO COLONIAL"  
PARIS, FRANCE  
1-4 a.m., 10:15 a.m.- 5 p.m.

**11870 kc. ★W8XK**  
-B- 25.26 meters  
WESTINGHOUSE ELECTRIC  
& MFG. CO.  
PITTSBURGH, PA.  
5:10-30 p.m.  
Fri. till 12 m  
Relays KDKA

**11860 kc. YDB**  
-B- 25.29 meters  
N.I.R.O.M.,  
SOERABAJA, JAVA  
Sat. 7 p.m.-1:30 a.m. (Sun.)  
Daily 10:30 p.m.-1:30 a.m.

**11860 kc. GSE**  
-B- 25.29 meters  
DAVENTRY,  
B.B.C., BROADCASTING  
HOUSE, LONDON, ENGLAND

**11855 kc. DJP**  
-B.X- 25-31 meters  
BROADCASTING HOUSE,  
BERLIN, GERMANY  
12 n.-2 p.m.

**11830 kc. W9XAA**  
-B- 25.36 meters  
CHICAGO FEDERATION OF  
LABOR  
CHICAGO, ILL.  
Relays WCFL 6:30 a.m.-4 p.m.,  
9 p.m.-12 m.

**11830 kc. ★W2XE**  
-B- 25.36 meters  
ATLANTIC BROADCASTING  
CORP.  
485 MADISON AVE., N. Y. C.  
Relays WABC 4-9 p.m.

**11820 kc. GSN**  
-B- 25.38 meters  
DAVENTRY  
B.B.C., BROADCASTING  
HOUSE,  
LONDON, ENGLAND  
11:30 p.m.-1:30 a.m. Irregular

**11810 kc. ★HJ4ABA**  
-B- 25.4 meters  
P. O. BOX 50,  
MEDELLIN, COLOMBIA  
11:30 a.m.-1 p.m., 6:30-10:30  
p.m.

**11810 kc. ★2RO**  
-B- 25.4 meters  
E.I.A.R.  
Via Montelio 5  
ROME, ITALY  
6:15-9 a.m., 9:15-11 a.m., 11:30  
a.m.-12:15 p.m., 1:30-5 p.m.

**11795 kc. DJO**  
-B.X- 25.43 meters  
BROADCASTING HOUSE,  
BERLIN, GERMANY  
3:45-5 p.m.

**11790 kc. W1XAL**  
-B- 25.45 meters  
BOSTON, MASS.  
Daily 5:15-6:15 p.m.  
Sun. 5-7 p.m.

**11770 kc. ★DJD**  
-B- 25.49 meters  
BROADCASTING HOUSE,  
BERLIN, GERMANY  
11:35 a.m.-4:20 p.m.; 4:50-  
10:55 p.m.

**11750 kc. ★GSD**  
-B- 25.53 meters  
DAVENTRY,  
B.B.C., BROADCASTING  
HOUSE, LONDON, ENGLAND  
12:15-3:25 p.m., 9-11 p.m.,  
11:30 p.m.-1:30 a.m.

**11730 kc. PHI**  
-B- 25.57 meters  
HUIZEN, HOLLAND  
Irregular

**11720 kc. ★CJRX**  
-B- 25.6 meters  
WINNIPEG, CANADA  
Daily, 8 p. m.-12 m.

**11715 kc. ★TPA4**  
-B- 25.61 meters  
"RADIO COLONIAL"  
PARIS, FRANCE  
5:15-9:15 p.m.,  
9:45 p.m.-12 m.

**11680 kc. KIO**  
-X- 25.88 meters  
KAHUKU, HAWAII  
Tests in the evening

**11595 kc. VRR4**  
-C- 25.87 meters  
STONY HILL, JAMAICA,  
B.W.I.  
Works WNC daytime.

**11560 kc. VIZ3**  
-X- 25.95 meters  
AMALGAMATED WIRELESS  
OF AUSTRALASIA  
FISKVILLE, AUSTRALIA  
Calls Canada evening and early  
a.m.

**11413 kc. CJA4**  
-C- 26.28 meters  
DRUMMONDVILLE,  
QUE., CAN.  
Tests with Australia irregularly  
in evening

**11200 kc. XBJQ**  
-X- 26.79 meters  
BOX 2825,  
MEXICO CITY, MEX.  
Irregular

**11050 kc. ZLT4**  
-C- 27.15 meters  
WELLINGTON, N. ZEALAND  
Phones Australia and England  
early a.m.

**11000 kc. PLP**  
-B.C- 27.27 meters  
BANDONG, JAVA  
Broadcasts Sat. 7 p.m.-1:30  
a.m., Sun. 5:30-10 a.m.  
Also 2-7 a.m. daily

**10970 kc. OCI**  
-C- 27.35 meters  
LIMA, PERU  
Works with Bogota, Col.,  
evenings

**10955 kc. HS8PJ**  
-B.X- 27.38 meters  
BANGKOK, SIAM  
Broadcasts 8-10:15 a.m. Mondays

**10840 kc. KWW**  
-C- 27.69 meters  
DIXON, CAL.  
Works with Hawaii evenings.

**10770 kc. GBP**  
-C- 27.85 meters  
RUGBY, ENGLAND  
Calls  
Sydney, Austral. early a. m.

**10740 kc. ★JVM**  
-B.C- 27.93 meters  
NAZAKI, JAPAN  
Broadcasts Tues. and Fri. 2-3  
p.m., Phones U.S. 2-7 a.m.

**10675 kc. WNB**  
-C- 28.1 meters  
LAWRENCEVILLE, N. J.  
Calls Bermuda, daytime

**10670 kc. ★CEC**  
-C- 28.12 meters  
SANTIAGO, CHILE  
Broadcasts Thurs., Sun.  
6:30-9 p.m., Daily 7-7:15 p.m.

**10660 kc. ★JVN**  
-B.C- 28.14 meters  
NAZAKI, JAPAN  
Phones Europe 3-8 a.m.  
Broadcasts daily 12 m.-1 a.m.,  
2-8 a.m.  
Mon. and Thurs. 4-5 p.m.

**10550 kc. WOK**  
-C- 28.44 meters  
LAWRENCEVILLE, N. J.  
Phones  
Argo., Braz., Peru, nights

**10520 kc. VLK**  
-C- 28.51 meters  
SYDNEY, AUSTRALIA  
Calls Rugby, early a.m.

**10430 kc. YBG**  
-C- 28.76 meters  
MEDAN, SUMATRA  
5:30-6:30 a. m., 7:30-8:30 p. m.

**10420 kc. XGW**  
-C- 28.79 meters  
SHANGHAI, CHINA  
Calls Manila and England, 6-9  
a.m. and California late evening

**10410 kc. PDK**  
-C- 28.80 meters  
KOOTWIJK, HOLLAND  
Calls Java 7:30-8:40 a. m.

**10410 kc. KES**  
-X- 28.80 meters  
BOLINAS, CALIF.  
Tests evenings

**10350 kc. LSX**  
-C- 28.98 meters  
MONTE GRANDE,  
ARGENTINA  
Tests irregularly 8 p.m.-12 mid-  
night.

**10330 kc. ORK**  
-B.C- 29.04 meters  
RUYSELEDE, BELGIUM  
Broadcasts 1:30-3 p.m.

**10300 kc. LSL2**  
-C- 29.13 meters  
HURLINGHAM, ARGENTINA  
Calls Europe, evenings

**10290 kc. DZC**  
-X- 29.16 meters  
ZEESEN,  
GERMANY  
Broadcasts Irregularly

**10260 kc. PMN**  
-B-C- 29.74 meters  
BANDENG, JAVA  
Calls Australia 5 a.m.  
Broadcasts Sat. 7 p.m.-1:30 a.m., Sun. 5:30-10 a.m.

**10250 kc. LSK3**  
-C- 29.27 meters  
HURLINGHAM, ARGENTINA  
Calls Europe and U. S., afternoon and evening

**10220 kc. PSH**  
-C- 29.35 meters  
RIO DE JANEIRO, BRAZIL

**10170 kc. RIO**  
-C- 29.5 meters  
BAKOU, U.S.S.R.  
Works with Moscow 10 p.m.-5 a.m.

**10169 kc. HSJ**  
-CX- 29.5 meters  
BANGKOK, SIAM  
Tests 9-10 a.m., Mon., Wed., Thur.

**10140 kc. OPM**  
-C- 29.59 meters  
LEOPOLDVILLE, BELGIAN CONGO  
Phones around 5 a.m. and 1-4 p.m.

**10080 kc. RIR**  
-C- 29.76 meters  
TIFLIS, U.S.S.R.  
Works with Moscow early morning.

**10070 kc. EDM-EHY**  
-C- 29.79 meters  
MADRID, SPAIN  
Works with S. America evenings

**10055 kc. ZFB**  
-C- 29.84 meters  
HAMILTON, BERMUDA  
Phones N. Y. C. daytime

**10055 kc. SUV**  
-C- 29.84 meters  
ABOU ZABAL, EGYPT  
Works with Europe 1-6 p.m.

**10042 kc. DZB**  
-X- 29.87 meters  
ZEESEN, GERMANY  
Works with Central America and tests 7-9 p.m.

**9990 kc. KAZ**  
-C- 30.03 meters  
MANILLA, P.I.  
Works with Java, Cal., and ships early morning

**9950 kc. GCU**  
-C- 30.15 meters  
RUGBY ENGLAND  
Calls N.Y.C. evening

**9930 kc. HKB**  
-C- 30.21 meters  
BOGOTA, COL.  
Phones Rio de Janeiro evenings

**9890 kc. LSN**  
-C- 30.33 meters  
HURLINGHAM, ARGENTINA  
Calls New York, evenings

**9870 kc. WON**  
-C- 30.4 meters  
LAWRENCEVILLE, N. J.  
Phones England, evening

**9860 kc. ★EAQ**  
-B- 30.43 meters  
P. O. Box 951  
MADRID, SPAIN  
Daily 5:15-9:30 p.m.; Saturday also 12 n.-2 p.m.

**9840 kc. JYS**  
-X- 30.49 meters  
KEMIKAWA-CHO, CHIBAKEN, JAPAN  
Irregular, 11:30 p.m.-3 a.m.

**9800 kc. LSI**  
-C- 30.61 meters  
MONTE GRANDE, ARGENTINA  
Tests irregularly

**9790 kc. GCW**  
-C- 30.64 meters  
RUGBY, ENGLAND  
Calls N.Y.C., evening

**9760 kc. VLJ-VLZ2**  
-C- 30.74 meters  
AMALGAMATED WIRELESS OF AUSTRALIA  
SYDNEY, AUSTRALIA  
Phones Java and N. Zealand early a.m.

**9750 kc. WOF**  
-O- 30.77 meters  
LAWRENCEVILLE, N. J.  
Phones England, evening

**9710 kc. GCA**  
-C- 30.89 meters  
RUGBY, ENGLAND  
Calls Arge. & Brazil, evenings

**9675 kc. DZA**  
-C- 31.01 meters  
ZEESEN, GERMANY  
Works with Africa and broadcasts 5-7 p.m.

**9660 kc. CQN**  
-B- 31.07 meters  
MACAO, PORTUGUESE CHINA  
Mon. and Fri. 7-8:30 a.m.

**9650 kc. YDB**  
-B- 31.09 meters  
N.I.R.O.M.  
SOERABAJA, JAVA  
4:30-10 a.m.

**9650 kc. ★CT1AA**  
-B- 31.09 meters  
"RADIO COLONIAL"  
LISBON, PORTUGAL  
Tues., Thurs., Sat. 3-6 p.m.

**9650 kc. DGU**  
-C- 31.09 meters  
NAUEN, GERMANY  
Works with Egypt in afternoon

**9645 kc. YNLF**  
-B- 31.1 meters  
MANAGUA, NICARAGUA  
8-9 a.m., 12:30-2:30, 6:30-10 p.m.

**9635 kc. ★2RO**  
-B- 31.13 meters  
E.I.A.R., ROME, ITALY  
M., W., F., 6-7:30 p.m.  
Tues., Thurs., Sat. 6-7:45 p.m.

**9600 kc. CB960**  
-B- 31.25 meters  
SANTIAGO, CHILE  
9:30 p.m. on

**9600 kc. HJ1ABP**  
-B- 31.25 meters  
P.O. BOX 37,  
CARTAGENA, COL.  
11 a.m.-1 p.m. 5-11 p.m.  
Sun. 10 a.m.-1 p.m., 3-6 p.m.

**9595 kc. ★HBL**  
-B- 31.27 meters  
LEAGUE OF NATIONS  
GENEVA, SWITZERLAND  
Saturdays, 5:30-8:15 p.m.  
Mon. at 1:45 a.m.

**9595 kc. HH3W**  
-B- 31.27 meters  
P.O. BOX 117,  
PORT-AU-PRINCE, HAITI  
1-2, 7-8:30 p.m.

**9590 kc. HP5J**  
-B- 31.28 meters  
APARTADO 867,  
PANAMA CITY, PANAMA  
11:45 a.m.-1 p.m., 7:30-10 p.m.

**9590 kc. ★PCJ**  
-B- 31.28 meters  
N. V. PHILIPS RADIOD  
EINDHOVEN, HOLLAND  
Rio 7-8 p.m.  
Wed 7-10 p.m.

**9590 kc. ★VK2ME**  
-B- 31.28 meters  
AMALGAMATED WIRELESS, LTD., 47 YORK ST.  
SYDNEY, AUSTRALIA  
Sun. 12 m-2 a.m., 4:30-8:30 a.m., 11:30 a.m.-1:30 p.m.

**9590 kc. ★W3XAU**  
-B- 31.28 meters  
PHILADELPHIA, PA.  
Relays WCAU  
Daily 11 a.m.-7 p.m.

**9580 kc. LRX**  
-B- 31.32 meters  
"EL MUNDO"  
BUENOS AIRES, ARGENTINA  
Testing

**9580 kc. ★GSC**  
-B- 31.32 meters  
DAVENTRY,  
B.B.C., BROADCASTING HOUSE, LONDON, ENGLAND  
6-8, 9-11 p.m.

**9580 kc. ★VK3LR**  
-B- 31.32 meters  
Research Section,  
Postmaster Gen'l's. Dept.,  
81 Little Collins St.,  
MELBOURNE, AUSTRALIA  
3:15-7:30 a.m., except Sun.  
also Fr. 10 p.m.-2 a.m.

**9570 kc. ★W1XK**  
-B- 31.35 meters  
WESTINGHOUSE ELECTRIC & MFG. CO.  
SPRINGFIELD, MASS.  
Relays WBZ, 6 a.m.-12 m.  
Sun 7 a.m.-12 m.

**9565 kc. VUB**  
-B- 31.38 meters  
BOMBAY, INDIA  
11 a.m.-12:30 p.m., Wed., Thurs., Sat.

**9560 kc. ★DJA**  
-B- 31.38 meters  
BROADCASTING HOUSE,  
BERLIN  
12:30-3, 8:05-11 a.m., 4:50-10:45 p.m.

**9550 kc. HJ1ABE**  
-B- 31.41 meters  
P.O. BOX 31,  
CARTAGENA, COLOMBIA  
Daily 7:30-9 p.m.,  
Mon. also 10 p.m.-12 m.

**9540 kc. ★DJN**  
-B- 31.45 meters  
BROADCASTING HOUSE-  
BERLIN, GERMANY  
12:30-3:50, 8:05-11 a.m., 4:50-10:45 p.m.

**9530 kc. ★W2XAF**  
-B- 31.48 meters  
GENERAL ELECTRIC CO.  
SCHENECTADY, N. Y.  
Relays WGY 4 p.m.-12 m.  
Sat. 12 n.-12 m.

**9525 kc. LKJ1**  
-B- 31.49 meters  
JELOY, NORWAY  
8-9 a.m., 11 a.m.-6 p.m.

**9510 kc. ★VK3ME**  
-B- 31.55 meters  
AMALGAMATED WIRELESS, Ltd.,  
167 Queen St.,  
MELBOURNE, AUSTRALIA  
Daily ex. Sun. 4-7 a.m.

**9510 kc. ★GSB**  
-B- 31.55 meters  
DAVENTRY,  
B.B.C., BROADCASTING HOUSE, LONDON, ENGLAND  
11:30 p.m.-1:30 a.m., 12:15-5:45 p.m.

**9510 kc. HJU**  
-B- 31.55 meters  
NATIONAL RAILWAYS  
BUENAVENTURA, COLOMBIA  
Mon., Wed., Fri. 8-11 p.m.

**9500 kc. PRF5**  
-B- 31.58 meters  
RIO DE JANEIRO, BRAZIL  
Irregularly 4:45-5:45 a.m.

**9490 kc. XGOX**  
-B- 31.61 meters  
NANKING, CHINA  
6:30-8:30 a.m., Sun. 7:30-9:30 a.m.

**9450 kc. TGW**  
-B- 31.75 meters  
MINISTRE de FOMENTO  
GUATEMALA CITY,  
GUATEMALA  
Daily 11 a.m.-1 p.m., 7-8, 9-11 p.m., Sat. 9 p.m.-5 a.m. (Sun.)

**9428 kc. ★COCH**  
-B- 31.8 meters  
2 B ST., VEDADO,  
HAVANA, CUBA  
Daily 8 a.m.-7 p.m.  
Sun. 11 a.m.-12 n.,  
8:30-9:30 p.m.

**9415 kc. PLV**  
-C- 31.87 meters  
BANDENG, JAVA  
Phones Holland around 9:45 a.m.

**9330 kc. CGA4**  
-C- 32.15 meters  
DRUMMONDVILLE, CANADA  
Phones England Irregularly

**9280 kc. GCB**  
-C- 32.33 meters  
RUGBY, ENGLAND  
Calls Can. & Egypt, evenings

**9170 kc. WNA**  
-C- 32.72 meters  
LAWRENCEVILLE, N. J.  
Phones England, evening

**9150 kc. YVR**  
-C- 32.79 meters  
MARACAY, VENEZUELA  
Works with Europe afternoons.

**9125 kc. ★HAT4**  
-B- 32.88 meters  
"RADIOLABOR,"  
GYALI-UT, 22  
BUDAPEST, HUNGARY  
Sunday 6-7 p.m.

**9060 kc. TFK**  
-C- 33.11 meters  
REYKJAVIK, ICELAND  
Phones London afternoons.  
Broadcasts irregularly.

**9020 kc. GCS**  
-C- 33.28 meters  
RUGBY, ENGLAND  
Calls N.Y.C., evenings

**9010 kc. KEJ**  
-C- 33.3 meters  
BOLINAS, CAL.  
Relays NBC & CBS  
Programs in evening irregularly

**8975 kc. VWY**  
-C- 33.43 meters  
KIRKEE, INDIA  
Works with England in morning

**8795 kc. HKV**  
-B- 34.09 meters  
BOGOTA, COLOMBIA  
Irregular; 6:30 p.m.-12 m.

**8775 kc. PNI**  
-C- 34.19 meters  
MAKASSER, CELEBES, N.I.  
Phones Java around 4 a. m.

**8765 kc. DAF**  
-C- 34.23 meters  
NORDEICH, GERMANY  
Works German Ships Irregularly

**8760 kc. GCQ**  
-C- 34.25 meters  
RUGBY, ENGLAND  
Calls S. Africa, afternoon

**8750 kc. ZCK**  
-B- 34.29 meters  
HONGKONG, CHINA  
Relays ZBW  
Daily 11:30 p.m.-1:15 a.m.  
Mon. and Thurs. 3-7 a.m.  
Tues., Wed., Fri. 6-10 a.m.  
Sat. 6-11 a.m.

**8730 kc. GCI**  
-C- 34.36 meters  
RUGBY, ENGLAND  
Calls India, 8 a. m.

**8680 kc. GBC**  
-C- 34.56 meters  
RUGBY, ENGLAND  
Calls ships

**8665 kc. CO9JQ**  
-X- 34.62 meters  
4 GENERAL GOMEZ  
CAMAGUEY, CUBA  
5:30-6:30, 8-9 p.m. daily  
except Sat. and Sun.

**8590 kc. YNVA**  
-B- 34.92 meters  
MANAGUA, NICARAGUA  
7:30-9:30 p. m.

**8560 kc. WOO**  
-C- 35.05 meters  
OCEAN GATE, N. J.  
Calls ships irregular

**8400 kc. HC2AT**  
-B- 35.71 meters  
CASSILLA 877  
GUAYAQUIL, ECUADOR  
8-11 p.m.

**8380 kc. IAC**  
-C- 35.8 meters  
Pisa, Italy

**8214 kc. HCJB**  
-B- 36.5 meters  
QUITO, ECUADOR  
7-11 p.m., except Monday  
Sun. 11 a.m.-12 n.; 4-10 p.m.

**8190 kc. XEME**  
-B- 36.63 meters  
CALLE 59, No. 517  
MERIDA, YUCATAN  
"LA VOZ de YUCATAN desde MERIDA"  
10 a.m.-12 n., 6 p.m.-12 m.

**8185 kc. PSK**  
-C- 36.65 meters  
RIO DE JANEIRO, BRAZIL  
Irregularly

**8036 kc. CNR**  
-B- 37.33 meters  
RABAT, MOROCCO  
Sunday, 2:30-5 p. m.

**7975 kc. HC2TC**  
-B- 37.62 meters  
QUITO, ECUADOR  
Thurs., Sun. at 8 p.m.

**7901 kc. LSL**  
-C- 37.97 meters  
HURLINGHAM, ARGENTINA  
Calls Brazil, night

**7880 kc. JYR**  
-B- 38.07 meters  
KEMIKAWA-CHO, CHIBAKEN, JAPAN  
4-7:40 a. m.

**7860 kc. SUX**  
-C- 38.17 meters  
ABOU ZABAL, EGYPT  
Works with Europe 4-6 p.m.

**7854 kc. HC2JSB**  
-B- 38.2 meters  
GUAYAQUIL, ECUADOR  
8:15-11:15 p.m.

**7830 kc. YV9RC**  
-B- 38.31 meters  
CARACAS, VENEZUELA  
7-11 p.m.

**7799 kc. ★HBP**  
-B- 38.47 meters  
LEAGUE OF NATIONS,  
GENEVA, SWITZERLAND  
5:30-6:15 p. m., Saturday

**7715 kc. KEE**  
-C- 38.89 meters  
BOLINAS, CAL.  
Relays NBC & CBS  
Programs in evening irregularly

**7630 kc. ZHJ**  
-B- 39.32 meters  
PENANG, MALAYA  
Daily 7-9 a.m.  
also Sat. 11 p.m.-1 A.M. (Sun.)

**7626 kc. RIM**  
-C- 39.34 meters  
TACHKENT, U.S.S.R.  
Works with Moscow early morning

**7620 kc. ETD**  
-C- 39.37 meters  
ADDIS ABABA, ETHIOPIA  
See 18270 kc.

**7610 kc. KWX**  
-C- 39.42 meters  
DIXON, CAL.  
Works with Hawaii, Philip-  
pines, Java and Japan nights.

**7550 kc. TI8WS**  
-B- 39.74 meters  
"ECOS DEL PACIFICO"  
P. O. BOX 75 PUNTA  
ARENAS, COSTA RICA  
8 p.m.-12 m.

**7520 kc. KKH**  
-C- 39.89 meters  
KAHUKU, HAWAII  
Works with Dixon and broad-  
casts irregularly nights

**7510 kc. JVP**  
-B-C- 39.95 meters  
NAZAKI, JAPAN

**7500 kc. RKI**  
-C- 40 meters  
MOSCOW, U.S.S.R.  
Works RIM early a.m.

**7390 kc. ZLT2**  
-C- 40.6 meters  
WELLINGTON, N.Z.  
Works with Sydney 3-7 a.m.

**7380 kc. XECR**  
-B- 40.65 meters  
FOREIGN OFFICE,  
MEXICO CITY, MEX.  
Sun. 6-7 p.m.

**7281 kc. HJ1ABD**  
-B- 41.04 meters  
CARTAGENA, COLO.  
Irregularly, evenings

**7100 kc. HKE**  
-B- 42.25 meters  
BOGOTA, COL., S. A.  
Tus. and Sat. 8-9 p. m.; Mon.  
& Thurs. 6:30-7 p. m.

**7080 kc. VP3MR**  
-B- 42.68 meters  
GEORGETOWN, BRI, GUI-  
ANA, S.A.  
Sun. 7:45-10:15 a.m.  
Daily 4:45-8:45 p.m.

**7074 kc. HJ1ABK**  
-B- 42.69 meters  
CALLE BOLIVIA,  
PROGRESO-IGUALDAD  
BARRANQUILLA, COLOMBIA  
Sun. 3-6 p.m.

**7030 kc. HRP1**  
-B- 42.67 meters  
SAN PEDRO SULA,  
HONDURAS  
Reported on this and other waves  
irregularly in evening

**6996 kc. PZH**  
-B- 42.88 meters  
P. O. BOX 18,  
PARAMIRABO, DUTCH  
GUIANA  
Sun. 9:36-11:36 a.m.  
Mon. and Fri. 5:36-9:36 p.m.  
Tues. and Thur. 8:36-10:36 a.m.,  
2:36-4:36 p.m.  
Wed. 3:36-4:36, 5:36-9:36 p.m.  
Sat. 2:36-4:36 p.m.

**6976 kc. HCETC**  
-B- 43 meters  
TEATRO BOLIVAR  
QUITO, ECUADOR  
Thurs. 11:11-9:30 p.m.

**6905 kc. GDS**  
-C- 43.45 meters  
RUGBY, ENGLAND  
Calls N.Y.C. evening

**6900 kc. HI3C**  
-B- 43.48 meters  
LA RAMONA, DOM. REP.  
LA VOZ DE RIO DULCE,  
11:55 a.m.-1:25 p.m., 6:10 p.m.-  
12 m.

(All Schedules Eastern Standard Time)

<p><b>6860 kc. KEL</b> -X- 43.70 meters BOLINAS, CALIF. Tests irregularly 11 a.m.-12 n.; 8-9 p.m.</p> <p><b>6850 kc. TIGOW</b> -B- 43.8 meters ONDA del CARIBE PUERTO LIMON, COSTA RICA Irregularly 8-9:30 p.m.</p> <p><b>6800 kc. HI7P</b> -B- 44.12 meters EMISORIA DIARIA de COMERCIO, CIUDAD TRUJILLO, DOM. REP. Daily exc. Sat. and Sun. 12:40-1:40; 6:40-8:40 p.m.; Sat. 12:40-1:40 p.m.; Sun. 10:40 a.m.-11:40 a.m.</p> <p><b>6780 kc. HIH</b> -B- 44.25 meters SAN PEDRO de MACORIS DOMINICAN REP. 12:10-1:40 p.m.; 7:30-9 p.m.; Sun. 3-4 a.m.; 4:15-6 p.m.</p> <p><b>6755 kc. WOA</b> -C- 44.41 meters LAWRENCEVILLE, N. J. Phonos England, evening</p> <p><b>6750 kc. JVT</b> -B-C- 44.44 meters NAZAKI, JAPAN KOKUSAI-DENWA KAISHA, LTD., TOKIO</p> <p><b>6710 kc. TIEP</b> -B- 44.71 meters LA-VOZ DEL TROPICO SAN JOSE, COSTA RICA APARTADO 257, Daily 7-10 p.m.</p> <p><b>6672 kc. YVQ</b> -C- 44.95 meters MARACAY, VENEZUELA Broadcasts Sat. 8-9 p.m.</p> <p><b>6660 kc. HC2RL</b> -B- 45.05 meters P. O. BOX 759, GUAYAQUIL, ECUADOR, S. A. Sunday, 5:45-7:45 p. m. Tues., 9:15-11:15 p. m.</p> <p><b>6650 kc. IAC</b> -C- 45.11 meters PISA, ITALY Cable ships, evenings</p> <p><b>6630 kc. HIT</b> -B- 45.25 meters "LA VOZ de la RCA VICTOR," APARTADO 1105, CIUDAD TRUJILLO, D.R. Daily exc. Sun. 12:10-1:40 p.m.; 5:40-8:40 p.m.; also Sat. 10:40 p.m.-12:40 a.m. (Sun.)</p> <p><b>6618 kc. PRADO</b> -B- 45.33 meters RIOBAMBA, ECUADOR Thurs. 9-11:45 p.m.</p> <p><b>6611 kc. RV72</b> -B- 45.38 meters MOSCOW, U. S. S. R. 1-8 p. m.</p> <p><b>6600 kc. H18A</b> -B- 45.45 meters CIUDAD TRUJILLO, DOM. REP. Irregular</p> <p><b>6560 kc. HI4D</b> -B- 45.73 meters CIUDAD TRUJILLO, DOMINICAN REPUBLIC Except Sun. 11:55 a.m.-1:40 p.m.; 4:40-7:40 p.m.</p> <p><b>6550 kc. TIRCC</b> -B- 45.77 meters RADIOEMISORA CATOLICA COSTARRICENSE SAN JOSE, COSTA RICA Sun. 11 a.m.-2 p.m.; 6-7, 8-9 p.m.; Daily 12 n.-2 p.m.; 6-7 p.m.; Thurs. 6-11 p.m.</p> <p><b>6520 kc. YV6RV</b> -B- 46.01 meters VALENCIA, VENEZUELA 11 a.m.-2 p.m.; 5-10 p.m.</p> <p><b>6500 kc. HIL</b> -B- 46.15 meters APARTADO 623 CIUDAD TRUJILLO, D.R. 12:10-1:40 p.m.; 5:40-7:40 p.m.</p> <p><b>6500 kc. HJ5ABD</b> -B- 46.15 meters MANIZALES, COL. 12-1:30 p. m.; 7-10 p. m.</p> <p><b>6480 kc. HI4V</b> -B- 46.3 meters CIUDAD TRUJILLO, D.R. LA VOZ de LA MARINA 11:40 a.m.-1:40 p.m.; 5:10-9:40 p.m.</p>	<p><b>6450 kc. HJ4ABC</b> -B- 46.51 meters APARTADO 39 IBAQUE, COLOMBIA 11 a.m.-12 n.; 8-11 p.m.</p> <p><b>6447 kc. HJ1ABB</b> -B- 46.53 meters BARRANQUILLA, COL., S. A. P. O. BOX 715, 11:30 a.m.-1 p.m.; 4:30-10 p.m.</p> <p><b>6425 kc. W9XBS</b> -X- 46.7 meters NATL. BROAD. CO. CHICAGO, ILL. Relays WMAQ, Irregular</p> <p><b>6420 kc. HI1S</b> -B- 46.73 meters PUERTO PLATA, DOM. REP. 11:40 a.m.-1:40 p.m.; 5:40-7:40; 9:40-11:40 p.m.</p> <p><b>6410 kc. TIPG</b> -B- 46.8 meters APARTADO 225, SAN JOSE, COSTA RICA "LA VOZ DE LA VICTOR" 12 n.-2 p.m.; 6-11:30 p.m.</p> <p><b>6380 kc. HI3U</b> -B- 47.02 meters SANTIAGO de los CABALLEROS, DOM. REP. 10:40 a.m.-1:40 p.m.; 4:40-9:40 p.m.</p> <p><b>6375 kc. YV4RC</b> -B- 47.08 meters CARACAS VENEZUELA 5:30-9:30 p.m.</p> <p><b>6316 kc. HIZ</b> -B- 47.5 meters CIUDAD TRUJILLO DOMINICAN REPUBLIC Daily except Sat. and Sun. 11:10 a.m.-2:25 p.m.; 5:10-8:40 p.m.; Sat. 3:10-11:10 p.m.; Sun. 11:40 a.m.-1:40 p.m.</p> <p><b>6300 kc. YV12RM</b> -B- 47.62 meters MARACAY, VENEZUELA 8-10:30 p.m.</p> <p><b>6280 kc. CO9WR</b> -B- 47.77 meters P.O. BOX 85, SANCTI SPIRITUS, CUBA 4-6; 9-11 p.m.</p> <p><b>6280 kc. HIG</b> -B- 47.77 meters CIUDAD TRUJILLO, D.R. 7:10-8:40 a.m.; 12:40-2:10; 8:10-9:40 p.m.</p> <p><b>6235 kc. HRD</b> -B- 48.12 meters La Voz de Atlantida LA CEIBA, HONDURAS 8-11 p.m.; Sat. 8 p.m.-1 a.m. (Sun.); Sun. 4-6 p.m.</p> <p><b>6230 kc. OAX4G</b> -B- 48.15 meters Apartado 1242 LIMA, PERU Daily 7-10:30 p.m. Wed. 6-10:30 p.m.</p> <p><b>6185 kc. HI1A</b> -B- 48.5 meters P. O. BOX 423, SANTIAGO, DOMINICAN REP. 11:40 a.m.-1:40 p. m. 7:40-9:40 p. m.</p> <p><b>6180 kc. XEXA</b> -B- 48.54 meters DEPT. OF EDUCATION MEXICO CITY, MEX. 7-11 p.m.</p> <p><b>6175 kc. HJ2ABA</b> -B- 48.58 meters TUNJA, COLOMBIA 1-2; 7:30-9:30 p.m.</p> <p><b>6170 kc. HJ3ABF</b> -B- 48.62 meters BOGOTA, COLOMBIA 7-11:15 p. m.</p> <p><b>6160 kc. YV3RC</b> -B- 48.7 meters CARACAS, VENEZUELA 11 a.m.-2 p.m.; 4-10:30 p.m.</p> <p><b>6155 kc. COKG</b> -B- 48.74 meters BOX 137, SANTIAGO, CUBA 9-10 a.m.; 11:30 a.m.-1:30 p.m.; 3-4:30 p.m.; 10-11 p.m.; 12 m.-2 a.m.</p> <p><b>6150 kc. CSL</b> -B- 48.78 meters LISBON, PORTUGAL 7-8:30 a.m.; 2-7 p.m.</p> <p><b>6150 kc. CJRO</b> -B- 48.78 meters WINNIPEG, MAN., CANADA 8 p.m.-12 m. Sun. 3-10:30 p. m.</p>	<p><b>6150 kc. HJ5ABC</b> -B- 48.78 meters CALI, COLOMBIA Daily 11 a.m.-12 n.; Sun. 12 n.-2 p.m.; Daily except Sat. and Sun. 7-10 p.m.</p> <p><b>6140 kc. W8XK</b> -B- 48.86 meters WESTINGHOUSE ELECTRIC &amp; MFG. CO. PITTSBURGH, PA. Relays KDKA 9 p.m.-12 m.</p> <p><b>6135 kc. HI5N</b> -B- 48.9 meters SANTIAGO D.R. 6:40-9:10 p.m.</p> <p><b>6130 kc. HJ4ABP</b> -B- 48.94 meters MEDELLIN, COL. Relays HJ4ABQ 8-11 p.m.</p> <p><b>6130 kc. TGXA</b> -B- 48.94 meters GIORNAL LIBERAL PROGRESSISTA, GAUTEMALA CITY, GUAT. Heard in the evening.</p> <p><b>6130 kc. COCD</b> -B- 48.94 meters "La Voz del Aire" CALLE G y 25, VEDADO, HAVANA, CUBA Relays CMCO 11 a.m.-12 n.; 7-10 p.m.; Sun. 12 n.-4 p.m.</p> <p><b>6130 kc. ZGE</b> -B- 48.94 meters KUALA LUMPUR, FED. MALAY STATES Sun., Tue. and Fri., 8:40-9:40 a. m.</p> <p><b>6130 kc. VE9HX</b> -B- 48.94 meters P.O. BOX 998 HALIFAX, N.S., CANADA Daily 9 a.m.-12:30 p.m.; 4-10 p.m. Relays CHNS</p> <p><b>6128 kc. HJ3ABX</b> -B- 48.95 meters LA VOZ de COLOMBIA CALLE 14 No. 735, BOGOTA, COLOMBIA 5:45-11:30 p.m.</p> <p><b>6120 kc. W2XE</b> -B- 49.02 meters ATLANTIC BROADCASTING CORP. 483 MADISON AVE., N. Y. C. Relays WABC, 9-10 p.m.</p> <p><b>6120 kc. XEFT</b> -B- 49.02 meters AV. INDEPENDENCIA 28, VERA CRUZ, MEX. 11 a.m.-4 p.m.; 7:30 p.m.-12 m. Sat., also 6:30-7:30 p.m. Sun. 11 a.m.-4 p.m.; 9 p.m.-12 m. Relays XEFT</p> <p><b>6110 kc. VUC</b> -B- 49.1 meters CALCUTTA, INDIA Daily except Sat., 8:50 a.m.; 9:30 a.m.-noon; Sat., 11:45 a.m.-3 p.m.</p> <p><b>6105 kc. HJ4ABB</b> -B- 49.14 meters MANIZALES, COL., S. A. P. O. Box 175 Mon. to Fri. 12:15-1 p.m.; Tues. &amp; Fri. 7:30-10 p.m.; Sun. 2:30-5 p.m.</p> <p><b>6100 kc. W3XAL</b> -B- 49.18 meters NATIONAL BROADCASTING CO. BOUND BROOK, N. J. Relays WJZ Monday, Wednesday, Saturday, 4-5 p.m.; Sat. 11 p.m.-12 m.</p> <p><b>6100 kc. W9XF</b> -B- 49.18 meters NATL. BROAD. CO. CHICAGO, ILL. Sun., Tues., Thurs., Fri. 12 m.-1 a.m.; 8 p.m.-11:59 p.m.; M., W., Sat., 12 m.-1 a.m. Relays WENR</p> <p><b>6097 kc. ZTJ</b> -B- 49.2 meters AFRICAN BROADCASTING CO. JOHANNESBURG, SOUTH AFRICA. Sun.-Fri. 11:45 p.m.-12:30 a.m. (next day) Mon.-Sat. 3:30-7 p.m. 9 a.m.-4 p.m. Sun. 8:10:15 a.m.; 12:30-3 p.m.</p> <p><b>6090 kc. CRCX</b> -B- 49.26 meters TORONTO, CANADA Daily 5:30-11:30 p.m. Sun. 11:45 a.m.-11:45 p.m.</p> <p><b>6090 kc. VE9BJ</b> -B- 49.26 meters SAINT JOHN, N. B., CAN. 7-8:30 p. m.</p>	<p><b>6085 kc. 2RO</b> -B- 49.3 meters E.I.A.R. ROME, ITALY</p> <p><b>6083 kc. VQ7LO</b> -B- 49.31 meters NAIROBI, KENYA, AFRICA Mon.-Fri. 5:45-6:15 a.m.; 11:30 a.m.-2:30 p.m. Also 8:30-9:30 a.m. on Tues. and Thurs.; Sat. 11:30 a.m.-3:30 p.m.; Sun. 11 a.m.-2 p.m.</p> <p><b>6080 kc. CP5</b> -B- 49.34 meters LAPAZ, BOLIVIA 7-10:30 p. m.</p> <p><b>6080 kc. HP5F</b> -B- 49.34 meters Carlton Hotel COLON, PANAMA 11:45 a.m.-1:15 p.m.; 7:45-10 p.m.</p> <p><b>6080 kc. W9XAA</b> -B- 49.34 meters CHICAGO FEDERATION OF LABOR CHICAGO, ILL. Relays WCFL Sunday 11:30 a. m., 9 p. m. and Tues., Thurs., Sat., 4 p. m.-12 m.</p> <p><b>6079 kc. DJM</b> -B-X- 49.34 meters BROADCASTING HOUSE, BERLIN, GERMANY</p> <p><b>6072 kc. OER2</b> -B- 49.41 meters VIENNA, AUSTRIA 9 a. m.-5 p.m.; Sat. to 6 p.m.</p> <p><b>6070 kc. HJ4ABC</b> -B- 49.42 meters PERIERA, COL. 9-11 a.m.; 7-8 or 9 p. m.</p> <p><b>6070 kc. VE9CS</b> -B- 49.42 meters VANCOUVER, B. C., CANADA Sun. 1:45-9 p. m.; 10:30 p. m.-1 a. m.; Tues. 6-7:30 p. m.; 11:30 p. m.-1:30 a. m. Daily 6-7:30 p. m.</p> <p><b>6065 kc. HJ4ABL</b> -B- 49.46 meters MANIZALES, COL. Daily 11 a.m.-12 n.; 5:30-7:30 p.m. Sat. 5:30-10:30 p.m.</p> <p><b>6060 kc. W8XAL</b> -B- 49.50 meters CROSBLEY RADIO CORP. CINCINNATI, OHIO 5:30 a.m.-7 p.m.; 10 p.m.-1 a.m. Relays WLW</p> <p><b>6060 kc. W3XAU</b> -B- 49.50 meters PHILADELPHIA, PA. Relays WCAU 7 p.m.-10 p.m.</p> <p><b>6060 kc. OXY</b> -B- 49.50 meters SKAMLEBOAEK, DENMARK 1-6:30 p.m.</p> <p><b>6050 kc. HJ3ABD</b> -B- 49.59 meters COLOMBIA BROADCASTING, BOX 509, BOGOTA, COL. 12 n.-2 p.m.; 7-11 p.m.; Sun. 5-9 p.m.</p> <p><b>6050 kc. HI9B</b> -B- 49.59 meters SANTIAGO DOM. REP. Irregular 6 p.m.-11 p.m.</p> <p><b>6042 kc. HJ1ABG</b> -B- 49.65 meters EMISORA ATLANTICO BARRANQUILLA, COLO. 11 a.m.- 11 p.m. Sun. 11 a.m.- 8 p.m.</p> <p><b>6040 kc. W4XB</b> -B- 49.67 meters MIAMI BEACH, FLA. Relays WIOD 12 n.-2 p.m.; 5:30 p.m.-12 m.</p> <p><b>6040 kc. PRA8</b> -B- 49.67 meters RADIO CLUB OF PERNAMBUCO PERNAMBUCO, BRAZIL 1-3 p.m.; 4-7:30 p.m. daily</p> <p><b>6040 kc. W1XAL</b> -B- 49.67 meters BOSTON, MASS. Tues., Thurs. 7:15-9:15 p.m. Sun 5-7 p.m.</p> <p><b>6040 kc. YDA</b> -B- 49.67 meters N.I.R.O.M. TANDJONGPRIOK, JAVA 5:45-6:45 p.m.; 10:30 p.m.-1:30 a.m.</p>	<p><b>6030 kc. HP5B</b> -B- 49.75 meters P. O. BOX 910 PANAMA CITY, PAN. 12 n.- 10 p.m.; 7-10:30 p.m.</p> <p><b>6030 kc. VE9CA</b> -B- 49.75 meters CALGARY, ALBERTA, CAN. Thurs. 9 a.m.-2 a.m. (Fri.); Sun. 12 n.-12 m. Irregularly on other days from 9 a.m.-12 m.</p> <p><b>6020 kc. DJC</b> -B- 49.83 meters BROADCASTING HOUSE, BERLIN 11:35 a.m.-4:20 p.m.</p> <p><b>6020 kc. XEUW</b> -B- 49.82 meters AV. INDEPENDENCIA, 98, VERA CRUZ, MEX. 8 a.m.-12:30 a.m.</p> <p><b>6020 kc. HJ1ABJ</b> -B- 49.83 meters SANTA MARTA, COLO. 6:30-10:30 p.m. except Wed.</p> <p><b>6018 kc. ZHI</b> -B- 49.8 meters RADIO SERVICE CO., 20 ORCHARD RD., SINGAPORE, MALAYA Mon., Wed. and Thurs 5:40-8:10 a.m. Sat. 10:40 p.m.-1:10 a.m. (Sun.) Every other Sunday 5:10-6:40 a.m.</p> <p><b>6012 kc. HJ3ABH</b> -B- 49.91 meters BOGOTA, COLO. APARTADO 565 8-11 p.m. Sun. 12 n.-2 p.m.; 4-11 p.m.</p> <p><b>6010 kc. COCO</b> -B- 49.92 meters P.O. BOX 98 HAVANA, CUBA Daily 9:30 a.m.-1 p.m.; 4-7 p.m.; 8-10 p.m. Sat. also 11:30 p.m.-2 a.m.</p> <p><b>6005 kc. HP5K</b> -B- 49.96 meters Box 33, COLON, PANAMA 7:30-9 a.m.; 12 n.-1 p.m.; 6-9 p.m.</p> <p><b>6005 kc. VE9DR</b> -B- 49.96 meters CANADIAN MARCONI CO., MONTREAL, QUE., CAN. Relays CFCE 7 a.m.-11 p.m.; Sun. 8 a.m.-10:15 p.m.</p> <p><b>6000 kc. HJ1ABC</b> -B- 50 meters QUIBDO, COLOMBIA 5-6 p.m.; Sun. 9-11 p.m.</p> <p><b>5990 kc. XEBT</b> -B- 50.08 meters MEXICO CITY, MEX. P. O. Box 79-44 8 a.m.-1 a.m.</p> <p><b>5988 kc. HJ2ABD</b> -B- 50.10 meters BUCARAMANGA, COL. 11:30 a.m.-12:30 p.m.; 5:30-6:30; 7:30-10:30 p.m.</p> <p><b>5980 kc. XEWI</b> -B- 50.17 meters MEXICO CITY, MEX. Mon., Wed., Fri., 3-4 p.m.; Tues., Fri. 7:30-8:45; 10 p.m.-12 m.; Sat. 9-10 p.m.; Sun. 1-2:15 p. m.</p> <p><b>5980 kc. HIX</b> -B- 50.17 meters CIUDAD TRUJILLO, DOMINICAN REP. Sun. 7:40-10:10; Daily 12:40-1:10 p.m.; 4:40-5:40 p.m.; Tues. and Fri. 8:10-10:10 p.m.</p> <p><b>5976 kc. HJ2ABC</b> -B- 50.2 meters CUCUTA, COLOMBIA 6-9:30 p.m.</p> <p><b>5970 kc. HJN</b> -B- 50.26 meters BOGOTA, COL. 6-11 p.m.</p> <p><b>5968 kc. HVJ</b> -B- 50.27 meters VATICAN CITY (ROME) 2-2:15 p. m., daily, Sun., 5-5:30 a. m.</p> <p><b>5940 kc. TG2X</b> -B- 50.5 meters GUATEMALA CITY, GUAT. 4-6, 9-11 p.m., Sun. 2-5 a.m.</p> <p><b>5930 kc. HJ4ABE</b> -B- 50.59 meters MEDELLIN, COLO. Daily 11 a.m.-12 n.; 6-10:30 p.m.</p>
--	---	---	--	--

(All Schedules Eastern Standard Time)



<p><b>5900 kc. HH2S</b> -B- 50.85 meters PORT-au-PRINCE, HAITI BOX A103, 7:30-10:30 p.m.</p> <p><b>5885 kc. HCK</b> -B- 50.98 meters QUITO, ECUADOR, S. A. 8-11 p.m.</p> <p><b>5880 kc. YV8RB</b> -B- 51.02 meters "LA VOZ de LARA" BARQUISIMETO, VENEZUELA (2 n.-1 p.m., 6-10 p.m.)</p> <p><b>5875 kc. HRN</b> -B- 51.06 meters TEGUCIGALPA, HONDURAS 1:15-2:15, 8:30-10 p.m., Sun. 3:30-5:30, 8:30-9:30 p.m.</p> <p><b>5865 kc. HI1J</b> -B- 51.15 meters BOX 204, SAN PEDRO de MACORIS, DOM. REP. 12 n.-2, 6:30-9 p.m.</p> <p><b>5853 kc. WOB</b> -C- 51.26 meters LAWRENCEVILLE, N. J. Calls Bermuda, nights</p>	<p><b>5850 kc. ★YV5RMO</b> -B- 51.28 meters CALLE REGISTRO, LAS DE- LICIAS APARTADO de COR- RES 214 MARACAIBO, VENEZUELA 11 a.m.-12:30 p.m., 5-9:30 p.m.</p> <p><b>5830 kc. ★TIGPH</b> -B- 51.5 meters ALMA TICA, APARTADO 800, SAN JOSE, COSTA RICA 11 a.m.-1 p.m., 6-10 p.m., Relays TIX 9-10 p.m.</p> <p><b>5800 kc. ★YV2RC</b> -B- 51.72 meters RADIO CARACAS CARACAS, VENEZUELA Sun. 8:30 a.m.-10:30 p.m. Daily 11 a.m.-1:30 p.m., 4-9:30 p.m.</p> <p><b>5790 kc. JVU</b> -C- 51.81 meters NAZAKI, JAPAN</p> <p><b>5780 kc. OAX4D</b> -B- 51.9 meters P.O. Box 853 LIMA, PERU Mon., Wed. &amp; Sat. 9-11:30 a.m.</p>	<p><b>5770 kc. HJ4ABD</b> -B- 51.99 meters LA VOZ CATTIA, MEDELLIN, COLOMBIA 8-11:30 p.m.</p> <p><b>5720 kc. YV10RSC</b> -B- 52.45 meters "LA VOZ de TACHIRA." SAN CRISTOBAL, VENEZUELA 6-11:30 p.m.</p> <p><b>5713 kc. TGS</b> -B- 52.51 meters GUATEMALA CITY, GUAT. Wed., Thurs. and Sun. 6-9 p.m.</p> <p><b>5500 kc. TI5HH</b> -B- 54.55 meters SAN RAMON, COSTA RICA Irregularly 3:30-4, 8-11:30 p.m.</p> <p><b>5145 kc. PMY</b> -B- 58.31 meters BANDOENG, JAVA 5:30-11 a.m.</p> <p><b>5077 kc. WCN</b> -C- 59.09 meters LAWRENCEVILLE, N. J. Phones England irregularly</p> <p><b>5025 kc. ZFA</b> -C- 59.7 meters HAMILTON, BERMUDA Calls U.S.A., nights</p>	<p><b>5000 kc. TFL</b> -C- 80 meters REYKJAVIK, ICELAND Calls London at night, Also broadcasts irregularly</p> <p><b>4975 kc. GBC</b> -C- 60.30 meters RUGBY, ENGLAND Calls Ships, late at night</p> <p><b>4820 kc. GDW</b> -C- 62.24 meters RUGBY, ENGLAND Calls N.Y.C., late at night</p> <p><b>4790 kc. VE9BK</b> -B-X- 62.63 meters RADIO SALES SERVICE, LTD., 780 BEATTY ST., VAN- COUVER, B.C., CAN. Daily exc. Sun. 11:30-11:45 a. m., 3-3:15, 8-8:15 p.m.</p> <p><b>4752 kc. WOO</b> -C- 63.1 meters OCEAN GATE, N. J. Calls ships irregularly</p> <p><b>4600 kc. HC2ET</b> -B- 65.22 meters Apartado 249 GUAYAQUIL, ECUADOR Wed., Sat., 9:15-11 p.m.</p>	<p><b>4320 kc. GDB</b> -C- 69.44 meters RUGBY, ENGLAND Tests, 8-11 p. m.</p> <p><b>4273 kc. RV15</b> -B- 70.20 meters KHABAROVSK, SIBERIA, U. S. S. R. Daily, 3-9 a.m.</p> <p><b>4272 kc. WOO</b> -C- 70.22 meters OCEAN GATE, N. J. Calls ships irregularly</p> <p><b>4098 kc. WND</b> -C- 73.21 meters HIALEAH, FLORIDA Calls Bahama Isles</p> <p><b>4002 kc. CT2AJ</b> -B- 74.95 meters PONTA DELGADA, SAO MIGUEL, AZORES Wed. and Sat. 5-7 p. m.</p> <p><b>3040 kc. YDA</b> -B- 98.66 meters N.I.R.O.M. TANDJONGPURIK, JAVA 5:30-11 a.m.</p>
--	---	--	---	--

# Alphabetical List of S-W Stations

## By Call-Letter and Frequency

(Frequency in Megacycles)

CALL	FREQ.	CALL	FREQ.	CALL	FREQ.	CALL	FREQ.	CALL	FREQ.	CALL	FREQ.	CALL	FREQ.
CB960	9.06 mc.	FZS2	11.99 mc.	HII	14.94 mc.	HVJ	15.12 mc.	OPL	20.04 mc.	TYA	12.22 mc.	W3XAL	17.78 mc.
CEC	19.68	GAA	20.38	HIL	6.50	HVJ	5.97	OPM	19.14	TYB	12.25	W3XAL	6.10
CEC	15.87	GAB	18.04	HIT	6.63	IAC	17.76	ORG	19.20	TYF	14.64	W3XAU	9.59
CEC	10.67	GAD	19.48	HIX	5.98	IAC	12.80	ORK	10.33	VE9BJ	6.09	W3XAU	6.06
CGA3	13.29	GAP	19.16	HIZ	6.32	IAC	8.38	OXY	6.06	VE9BK	4.79	W3XL	17.31
CGA4	9.33	GAQ	18.97	HI1A	6.19	IAC	6.65	PCJ	15.22	VE9CA	6.03	W4XB	6.04
CJA3	11.41	GAS	18.31	HI1J	5.86	IDU	13.39	PCJ	9.59	VE9CS	6.07	W3XAL	6.06
CJRO	6.15	GAU	18.62	HI1S	6.42	(1)2RO	11.81	PCV	17.81	VE9DR	6.01	W3XK	21.54
CJRX	11.72	CAW	18.20	HI1C	6.90	ZRO	9.64	PKD	10.41	VE9HX	6.13	W3XK	15.21
CNR	12.83	GBA	13.99	HI1D	6.38	JVE	15.66	PDV	12.06	VIZ3	11.56	W3XK	11.87
CNR	8.04	GBB	13.59	HI1A	6.56	JVF	15.62	PHI	17.78	VK2ME	9.59	W3XK	6.14
COCD	6.13	GBC	17.08	HI1V	6.48	JVH	14.60	PHI	11.73	VK3LR	9.58	W3XWJ	31.60
COCH	9.43	GBC	12.78	HISN	6.14	JVM	10.74	PLE	18.83	VK3ME	9.51	W3XAA	11.83
COCO	6.01	GBC	8.68	HI7P	6.80	JVN	10.66	PLP	9.42	VLJ	9.72	W3XAA	6.08
COKG	6.16	GBC	4.98	HISA	6.60	JVP	7.51	FLV	11.00	VLK	10.56	W3XBS	6.43
CO9JQ	8.67	GBL	14.65	HISB	6.05	JVT	6.75	PMA	19.35	VLZ2	9.76	W3XK	6.10
CO9WR	6.28	GBP	10.77	HJ1A3	14.94	JVU	5.79	PMC	18.14	VPD	13.08	W3XK	11.20
CP5	6.08	GBS	12.15	HJB	14.95	JYK	13.61	PMN	10.26	VP3MR	7.08	XEBT	5.99
CQN	9.66	GBU	12.29	HJN	5.97	JYR	7.88	PMY	5.15	VQ7LO	6.08	XECR	7.38
CRCX	6.09	GBW	14.44	HJU	0.70	JYS	9.84	PNI	8.78	VRR4	11.60	XEFT	6.12
CSL	6.15	GCA	9.71	HJ1ABB	6.45	JYT	15.76	PPU	19.26	VUB	9.57	XEME	6.19
CT1AA	9.65	GCB	9.28	HJ1ABC	6.0	KAY	14.98	PRAD0	6.62	VUC	6.11	XEUW	6.02
CT1GO	12.40	GCI	8.73	HJ1ABD	7.28	KAZ	9.99	PRAS	6.04	VWY	8.98	XEVI	5.98
CT2AJ	4.00	GCJ	13.42	HJ1ABE	9.55	KEE	7.72	PRF5	9.50	VWY2	17.51	XEXA	6.18
DAF	12.33	GCQ	8.76	HJ1ABG	6.04	KEJ	9.01	PSA	21.08	WCN	5.08	XGM	17.65
DAF	8.77	GCS	9.02	HJ1ABJ	6.02	KEL	6.86	PSD	15.07	WKA	21.06	XGOX	9.49
DFB	17.52	GCU	9.95	HJ1ABK	7.07	KES	10.41	PSF	14.96	WKF	19.22	XGW	10.42
DGU	9.650	GCW	9.79	HJ2ABA	6.18	KIO	11.68	PSH	10.22	WKK	21.42	YBG	10.43
DJA	9.560	GDE	4.32	HJ2ABC	5.98	KKH	7.52	PSK	8.19	WKN	19.82	YDA	6.04
DJB	15.20	GDS	0.91	HJ2ABD	5.98	KKR	15.46	RIM	15.25	WLA	18.34	YDA	3.04
DJC	6.02	GDW	4.82	HJ3ABD	6.05	KKZ	13.69	RIM	7.63	WLK	16.27	YDB	9.65
DJD	11.77	GSB	9.51	HJ3ABF	6.17	KTO	16.24	RIO	10.17	WMA	13.39	YDB	11.46
DJE	17.76	GSC	9.58	HJ3ABH	6.01	KWO	15.42	RIR	10.08	WMF	14.47	YNA	14.49
DJL	15.11	GSD	11.75	HJ3ABX	6.13	KWU	15.36	RKI	15.09	WMN	14.59	YNLF	9.65
DJM	6.08	GSE	11.86	HJ4ABA	11.81	KWV	10.84	RNE	7.50	WNA	9.17	YVC	13.35
DJN	9.54	GSF	15.14	HJ4ABB	6.11	KWX	7.61	RV15	12.0	WNB	10.68	YVQ	6.67
DJO	11.8	GSJ	17.79	HJ4ABC	6.45	LKJ1	9.53	SPW	4.27	WNC	15.06	YVR	18.30
DJP	11.86	GSH	21.47	HJ4ABD	6.07	LRU	15.29	SUV	13.64	WND	4.10	YVR	9.15
DJQ	15.28	GSI	15.26	HJ4ABE	5.77	LRX	9.58	SUX	10.06	WOA	6.76	YV2RC	5.80
DJR	15.34	GSJ	21.53	HJ4ABE	5.93	LSF	19.60	SUZ	7.86	WOB	5.85	YV3RC	6.16
DZA	9.68	GSN	11.82	HJ4ABL	6.06	LSG	19.90	TFJ	13.82	WOF	14.47	YV4RC	6.38
DZB	10.04	GSO	15.18	HJ4ABP	9.60	LSI	9.80	TFK	12.24	WOG	16.27	YV5RMO	5.85
DZC	10.29	GSP	15.31	HJ5ABC	6.15	LSK3	10.25	TFL	9.06	WOK	10.55	YV6RV	6.52
DZE	12.13	HAS3	15.37	HJ5ABD	6.50	LSL	15.81	TGF	5.0	WON	9.87	YV8RB	5.84
DZG	15.36	HAT4	9.13	HKB	9.93	LSL2	10.30	TGS	14.49	WOO	17.62	YV9RC	7.83
DZH	14.46	HBJ	14.54	HKE	7.10	LSM2	14.50	TGW	5.71	WOO	12.84	YV10RSC	5.72
EAQ	9.86	HBL	9.60	HKV	8.80	LSN	9.89	TGX	9.45	WOO	4.75	YV12RM	6.30
EDM	20.86	HBP	7.80	HKE	14.49	LSN5	14.53	TG2X	6.13	WOO	4.27	ZBW	8.75
EDM	10.07	HCETC	6.98	HPSB	6.03	LSN6	19.65	TIEP	5.94	W1XAL	15.25	ZFA	5.03
EHY	20.86	HCJB	8.21	HPSF	6.08	LSN5	21.02	TIGPH	6.71	W1XAL	11.79	ZFB	10.06
EHY	10.07	HCK	5.89	HPSJ	6.01	LSN6	10.35	TIPG	5.83	W1XAL	6.04	ZGE	6.13
ETA	18.27	HC2AT	8.40	HRD	6.24	LSY	20.70	TIR	6.41	W1XK	9.57	ZHI	6.02
ETB	11.96	HC2ET	4.60	HRF	14.49	LSY3	18.12	TIRCC	14.49	W2XAF	15.33	ZHJ	7.63
ETD	7.62	HC2J5B	7.85	HRL5	14.49	LZA	14.97	TISHH	6.55	W2XAF	9.53	ZLT2	7.39
FTA	11.94	HC2RL	6.66	HRN	5.88	OAX4D	5.78	T160W	5.50	W2XE	21.52	ZLT4	11.05
FTK	15.88	HC2TC	7.98	HRP1	7.03	OAX4G	6.23	T18WS	7.55	W2XE	17.76	ZSS	18.89
FTM	19.36	HN25	5.91	HS8PJ	10.96	OCI	18.68	TPA2	15.25	W2XE	15.27	ZTJ	6.10
FTO	18.25	HN3W	9.60	HSP	10.17	OCJ2	14.85	TPA3	11.88	W2XE	11.83		
FZS A	18.35	H1H	6.78			OER2	6.07	TPA4	11.72	W2XE	6.12		

"WHEN TO LISTEN IN" Appears on Page 241

# Short Wave

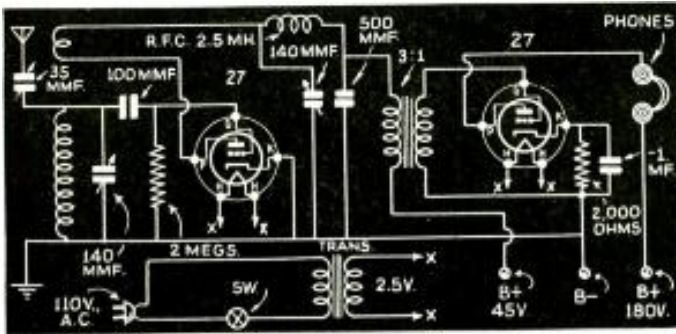

2-tube receiver using type 27's.

### 2-TUBE DIAGRAM

Walter Newton, St. Louis, Mo.

(Q) I would like to have a circuit diagram of two type 27 tubes in a receiver. One tube used as a detector and another as an audio amplifier. This is for A.C. operation, using a filament transformer; would you please print this in your Question Box?

(A) In the diagram shown employing two type 27 tubes, the heater voltage is furnished by a 2½-volt filament transformer. The B voltage may be supplied either by batteries or a B eliminator.

An eliminator delivering anywhere from 180 to 250 volts should be satisfactory. Of course, the "hum level" should be low, and this means that good filtering must be effected. Some of the older eliminators produced considerable hum.

thing in the order of 500 to 1,000 henries will be entirely satisfactory.

### CANNOT UNDERSTAND DIAGRAM

J. A. Lawrence, Winnipeg, Man., Canada

(Q) In one of your Question Box diagrams I see that you have a 45-volt connection to the earphones on the plus side only, and the negative goes to the ground and filament of the tube. I would like to know how anything can come through this set without being bucked out by the positive voltage in the phones. Also, I cannot see any negative return to the battery.

(A) The battery circuit you refer to can easily be traced by starting with the battery at the B negative connection, going through the filament of the tube, then through

in the phones, the signals would not be effected, even though it might shorten the life of the phones.

### POWER SUPPLY QUERY

Daniel Murray, New Rochelle, N.Y.

(Q) In one of the diagrams in a past issue of the Question Box I see that you have a 250-volt transformer and the output of the power-pack is also rated at 250 volts. No allowance seems to have been made for a voltage drop in the chokes, which I presume would have a resistance of around 400 ohms. Would this not reduce the output voltage?

(A) Offhand, it may seem peculiar that the output of the power-pack is designated as 250 volts with a 250-volt transformer, but remember, we have condenser-input which boosts the voltage considerably above 250. The two chokes do provide a voltage drop but even this is not sufficient to drop the voltage below 250. In fact, the voltage under operating conditions may be greater than 250 volts. For instance, as a specific example, a transformer having around 550 volts output, when fed through a rectifier and a condenser input filter delivered 600 volts with a 200 ma. load. The voltage of course without the 200 ma. load was well over 700.

### COIL DATA

Herbert Jackson, Johannesburg, So. Africa

(Q) I would appreciate very much if you would print informa-

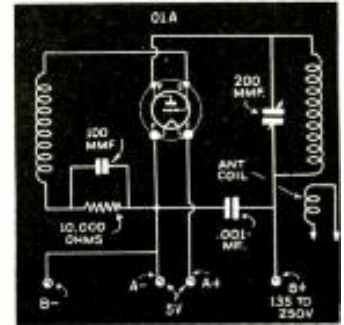

1-tube transmitter.

tion for very low power a license is not necessary. As we have stated many times, this is not true, and we endeavor to discourage our readers in entertaining any such idea that it may be permissible to operate a very low-powered transmitter without a license.

### 1-TUBE CRYSTAL TRANSMITTER

Leland Fossen, Terris, Minn.

(Q) Is it possible to construct a low-powered transmitter using a 33 tube and a crystal? This is to be used for C. W. operation on the amateur bands. If such an arrangement is practicable kindly print the diagram in the Question Box.

(A) If you live in a rural district where A.C. is not available, the low-powered crystal transmitter such as shown in the diagram

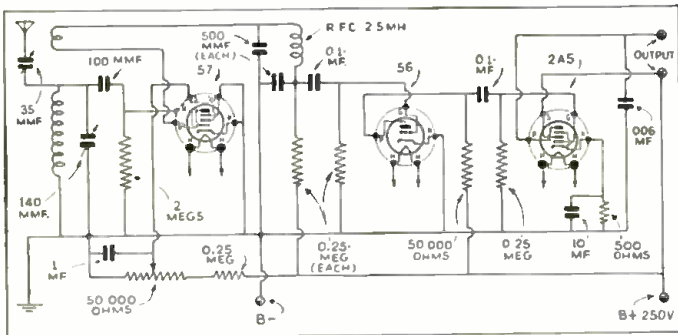

57, 56, and 2A5 as detector and two audios.

### 3 TUBER

Malcom Stetell, Caldwell, N. J.

(Q) Will you please publish a diagram of a 57, 56 and 2A5 using either resistance or impedance coupling between the 57 and 56?

(A) The diagram requested is given here. Resistance coupling is shown, although the plate resistor of the 57 may be replaced with a high impedance A.F. choke. Some-

the tube to the plate via the electron stream and from the plate back through the earphones to the B plus. These are the proper connections and there would be no danger of the plate current of the tube affecting reception, in so far as the earphones are concerned. There is nothing wrong with the diagram we assure you.

Even if there was a heavy current

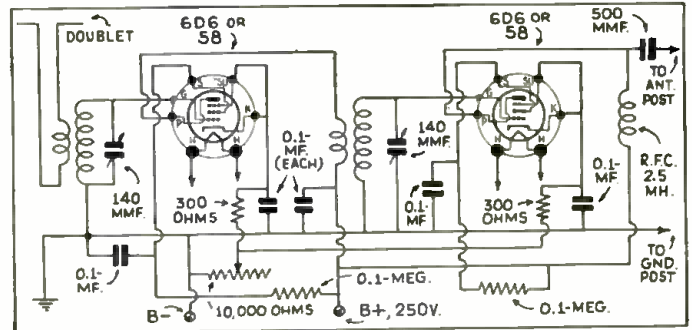

Diagram for 2-Stage R.F. Amplifier

tion in your Question Box on winding coils for various receivers to cover the 20, 40, 80 and 160 meter amateur bands.

(A) We are again reprinting data for winding coils of both the 4 and 6 prong variety, having two and three winding. This data will serve for practically every type of short-wave receiver described in Short Wave Craft. These coils are designed to tune with a 140 mf. condenser with sufficient overlap between the coils to insure full coverage.

should work out very nicely. On the 80 and 40-meter bands, of course, you will have to contend with the higher powered stations, but in the early hours of the morning when few are on and during the day, DX may be quite easily accomplished. With the new 20-meter crystals now being available, operation on 20 meters with a 1-tube crystal controlled transmitter proves very satisfactory.

### 1-TUBE TRANSMITTER USING 01A

Bud Brady, Seneca, Mo.

(Q) I would like to build a transmitter using a type 201A tube. Will you be kind enough to print a simple diagram?

(A) We are showing the circuit diagram of a T.N.T. oscillator using an 01A tube. Remember, of course, that a license is necessary in order to operate any type of transmitter. Many of the uninitiated are under the impression that

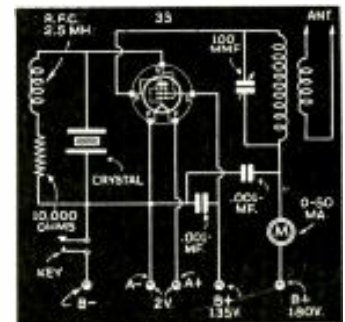

Simplest transmitter.

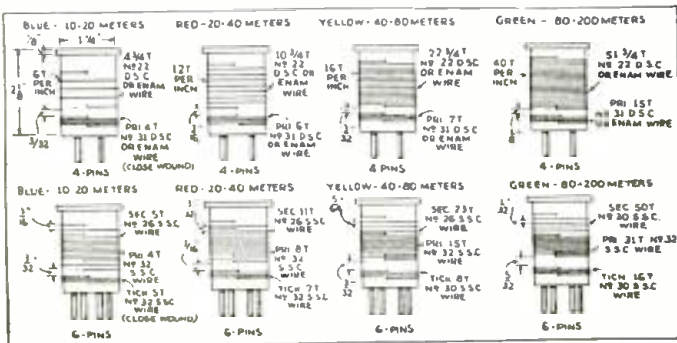

Coil data for 2 and 3-winding, 4 and 6-prong coils.

EDITED BY GEORGE W. SHUART, W2AMN

Because the amount of work involved in the drawing of diagrams and the compilation of data, we are forced to charge 25c each for letters that are answered directly through the mail. This fee includes only hand-drawn schematic drawings. We cannot furnish "picture-layouts" or "full-sized" working drawings. Letters not accompanied by 25c will be answered in turn on this page. The 25c remittance may be made in

the form of stamps, coin or money order.

Special problems involving considerable research will be quoted upon request. We cannot offer opinions as to the relative merits of commercial instruments.

Correspondents are requested to write or print their names and addresses clearly. Hundreds of letters remain unanswered because of incomplete or illegible addresses.

# QUESTION BOX

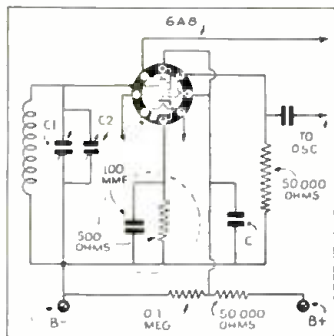

Converter correction.

## 10-METER CONVERTER

We are reprinting a revised diagram of the detector circuit of the 10-meter converter which appeared in the May issue of *Short Wave Craft*. It will be noticed that we have incorporated a 500-ohm resistor and a .0001 mf. by-pass con-

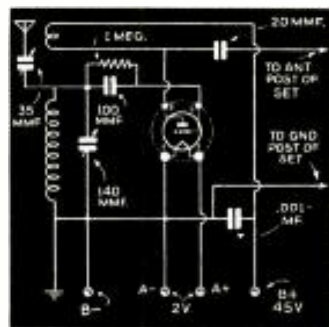

1-tube converter.

denser in the cathode circuit. This addition should be made in order to obtain satisfactory results. The condenser and resistor were omitted from the original diagram.

## 1-TUBE CONVERTER

Floyd Simmon, Oakland, Calif.  
(Q) I would like to construct a 1-tube converter using a type 30 tube. I have been told that such an arrangement works out very well.  
(A) This 1-tube converter must

necessarily be of the autodyne type. While it provides fair sensitivity the same station will be received in two places on the dial and both positions will provide the same signal strength. This is one reason why the 1-tube converter never became very popular, aside from its being less sensitive than the usual type.

## RECEIVER USING TWO 30's

S. Lipshitz, New York, N.Y.  
(Q) I would like to construct a set using two type 30 tubes, using 22½ volts on the plates. Would you kindly print the diagram?  
(A) The diagram you request is shown. However, we believe more satisfactory results would be obtained with 45 volts on the plates of the tubes and probably the set would be less critical in operation.

## BEST SET FOR FIVE METERS

V. J. Pilvelatis, Cambridge, Mass.  
(Q) I would like to know if it is possible to use a straight regenerative receiver for 5 meter operation. If so, will satisfactory results be obtained.  
(A) In the early stages of 5 meter radio straight regenerative receivers were used but were replaced by the super-regenerator because of the greater stability. A straight regenerative detector is not recommended for five meters.

## POWER SUPPLY DIAGRAM

Walter H. Burden, Chicago, Ill.  
(Q) I have constructed several simple receivers described in past issues of *Short Wave Craft*, and would like to build a power-supply to operate them. Would you be kind enough to print the necessary diagram?  
(A) We have printed the diagram you request, and we might add that if you have not already purchased a power transformer, you endeavor to obtain one having both 2.5 and 6.3 volt filament windings, because this will permit the use of either type tubes. Many readers

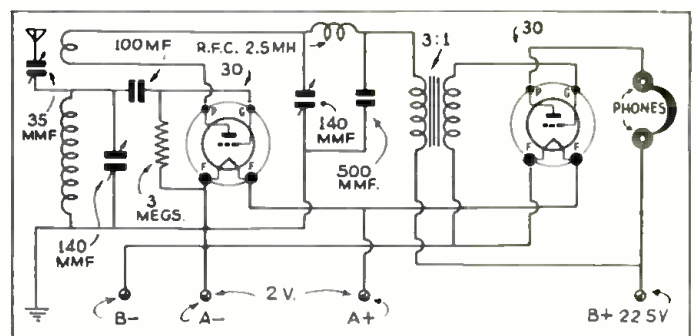

2-tube battery receiver using type 30 tubes.

are interested in trying out the new metal tubes and find that they lack the necessary filament or heater supply voltage.

printing the diagram for those who were unfortunate in missing the December, 1934 issue.

## WEAK SIGNALS ON SUPERHET

Richard Lindauer, Belleville, Ill.  
(Q) I have constructed a 6-tube superheterodyne but it is sensitive only on one set of plug-in coils. On the other coils I receive only one or two stations very weakly. What do you think is the trouble?  
(A) We suggest that you look for your trouble in the plug-in coils. From what you state, it would seem that the coils which do not give satisfactory performance are not tuning properly. You will find with a superhet the oscillator coils should have slightly less turns than the detector coils, unless you have a very large paddler on the detector which will permit constant readjustment as the set is tuned.

## 4-TUBE RESISTOR DIAGRAM

Charles Allen, Southington, Conn.  
(Q) Please publish in the next issue of the *Question Box* a circuit

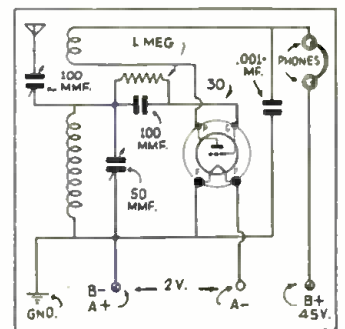

The famous pocket set.

## POCKET SET

Allen Clark, N.S.W., Australia.  
(Q) I have read much comment on the 1-tube pocket set described in the December, 1934 issue. However, I have been unable to obtain that issue and would be pleased if you would print the diagram in your "Question Box."  
(A) The 1-tube pocket receiver was very popular among our readers and excellent results have been obtained with this receiver. We are

for a "Ham" receiver using four 2.5 volts A.C. tubes. Two of them should be transformer-coupled in the audio amplifier. Also incorporate hand-spread and 140 mmf. condensers.

(A) The diagram you request is shown and hand-spread is accomplished by connecting 35 mmf. condensers in parallel with the large tuning condensers. We would not recommend transformer coupling, as you are liable to run into considerable difficulties.

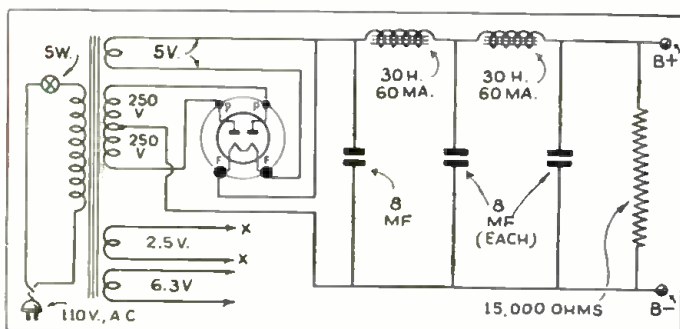

Power supply diagram for any S-W receiver.

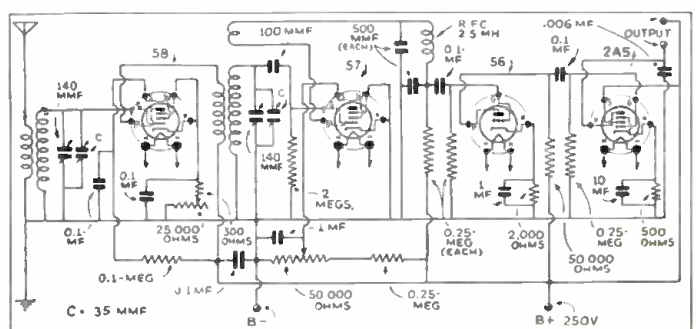

T. R. F. receiver of the most popular design.

# SHORT

## TWENTY-NINTH "TROPHY CUP"

Presented to  
SHORT WAVE SCOUT  
SAMUEL SOLITO  
Leitsdale, Pa.

For his contribution toward the  
advancement of the art of Radio

by



Magazine

### 29th TROPHY WINNER 100 Stations—79 Foreign

● IT HAS been quite some time since one of our Trophy Winners has had a total of 100 stations. This surely is a mark for you other fellows to shoot at. The receiver used by Mr. Solito was a National FB-7A superheterodyne, employing 8 tubes and 2 antennas. One antenna was a 66-foot doublet pointing east and west; the other was a 50-foot flat-top of the Marconi type, running north and south. Both earphones and speaker were used in the reception of these stations.

Verified List of Short Wave Stations Heard  
CALL—FREQ.—TITLE and LOCATION

W1XK—9,570 kc.—Boston Mass.  
W1XAL—11,790 kc.—Boston, Mass.  
W1XAI—6,040 kc.—Boston, Mass.  
W2XE—6,120 kc. (1)—New York, N.Y.  
W2XE—11,830 kc. (2)—New York, N.Y.  
W2XE—15,270 kc. (3)—New York, N.Y.  
W3XAL—17,780 kc.—Bound Brook, N.J.  
W3XAL—6,100 kc.—Bound Brook, N.J.  
W3XAU—6,060 kc.—Philadelphia, Pa.  
W3XAU—9,590 kc.—Philadelphia, Pa.  
W4XB—6,040 kc.—Miami, Fla.  
W8XAL—6,060 kc.—"Crosley Radio," Cincinnati, Ohio  
W8XK—6,140 kc.—Pittsburgh, Pa.  
W8XK—11,870 kc.—Pittsburgh, Pa.  
W8XK—15,210 kc.—Pittsburgh, Pa.  
W8XK—21,540 kc.—Pittsburgh, Pa.  
W9XAA—6,080 kc.—Chicago, Ill.  
W9XF—6,100 kc.—Chicago, Ill.  
KWU—15,355 kc.—Dixon, Calif.  
KWV—7,610 kc.—Dixon, Calif.



# WAVE . SCOUTS

## Honorable Mention Awards

Leo J. Vince, 2805 E. 117th St.,  
Cleveland, Ohio  
Wm. Rickards, R.R. No. 1, Mount  
Hamilton, Ont., Canada

CALL—FREQ.—TITLE and LOCATION

KWV—10,840 kc.—Dixon, Calif.

Foreign Stations

CJRO—6,150 kc.—Winnipeg, Canada.  
CJRX—11,720 kc.—Winnipeg, Canada.  
VE9CA—6,030 kc.—"The Voice of the Prairies,"  
Calgary, Canada.  
VE9BK—4,795 kc.—Vancouver, B.C., Canada.  
VE9HX—6,110 kc.—Halifax, N.S.  
VE9—6,000 kc.—Goderich, Canada.  
COCD—6,010 kc.—Havana, Cuba.  
COCD—6,130 kc.—"La Voz Del Aire," Havana,  
Cuba.  
XEFT—6,120 kc.—"La Voz de Vera Cruz," Vera  
Cruz, Mexico.  
XEUW—6,020 kc.—"El Eco de Sotavento Desde  
Vera Cruz," Vera Cruz, Mexico.  
XEFT—6,060 kc.—"El Buen Tono S.A.,"  
Mexico City, Mexico.  
(Continued on page 249)

● ON this page is illustrated the handsome trophy which was designed by one of New York's leading silversmiths. It is made of metal throughout, except the base, which is made of handsome black Bakelite. The metal itself is quadruple silver-plated, in the usual manner of all trophies today.

It is a most imposing piece of work, and stands from tip to base 22 1/4". The diameter of the base is 7 3/4". The diameter of the globe is 5 1/4". The work throughout is first-class, and no money has been spared in its execution. It will enhance any home, and will be admired by everyone who sees it.

The trophy will be awarded every month, and the winner will be announced in the following issue of SHORT WAVE CRAFT. The winner's name will be hand engraved on the trophy.

The purpose of this contest is to advance the art of radio by "logging" as many short-wave phone stations, amateurs excluded, in a period not exceeding 30 days, as possible by any one contestant. The trophy will be awarded to that SHORT WAVE SCOUT who has logged the greatest number of short-wave stations during any 30-day period.

## Trophy Contest Entry Rules

● THE rules for entries in the SHORT WAVE SCOUT Trophy Contest have been amended and 50 per cent of your list of stations submitted must be "foreign." The trophy will be awarded to the SHORT WAVE SCOUT who has logged the greatest number of short-wave stations during any 30 day period; (he must have at least 50 per cent "foreign" stations). This period need not be for the immediate month preceding the closing date. The complete list of rules appeared in the September issue of this magazine.

In the event of a tie between two or more contestants, each logging the same number of stations (each accompanied by the required minimum of 50 per cent "foreigns") the judges will award a similar trophy to each contestant so tying. Each list of stations heard and submitted in the contest must be sworn to before a Notary Public and testify to the fact that the list of stations heard were "logged" over a given 30 day period, that reception was verified and that the contestant personally listened to the station announcements as given in the list.

Only commercial "phone" stations should be entered in your list, no "amateur transmitters" or "commercial code" stations. This contest will close every month on the 25th day of the

month, by which time all entries must be in the editors' hands in New York City. Entries received after this date will be held over for the next month's contest. The next contest will close in New York City July 25th; any entries received after that date will be held over till the next month.

The winner each month will be the person sending in the greatest number of verifications. Unverified stations should not be sent in, as they will not count in the selection of the winner. At least 50 percent of the verifications sent in by each listener must be for stations located outside of the country in which he resides! In other words, if the contestant lives in the United States at least 50 percent of his "veries" must be from stations outside of the United States. Letters or cards which do not specifically verify reception, such as those sent by the Daventry stations and, also by commercial telephone stations, will not be accepted as verifications. Only letters or cards which "specifically" verify reception of a "given station," on a given wave length and on a given day, will be accepted! In other words it is useless to send in cards from commercial telephone stations or the Daventry stations, which state that specific verifications will not be given. Therefore do not put such

stations on your list for entry in the trophy contest!

SHORT WAVE SCOUTS are allowed the use of any receiving set, from a one-tuber up to one of sixteen tubes or upwards, if they so desire.

When sending in entries, note the following few simple instructions: Type your list, or write in ink, pencilled matter is not allowed. Send verification cards, letters and the list all in one package, either by mail or by express prepaid; do not split up the package. Verification cards and letters will be returned, at the end of the contest, to their owners; the expense to be borne by SHORT WAVE CRAFT magazine.

In order to have uniformity of the entries, when writing or typing your list, observe the following routine: USE A SINGLE LINE FOR EACH STATION; type or write the entries IN THE FOLLOWING ORDER: Station call letters; frequency station transmits at; schedule of transmission, if known (all time should be reduced to Eastern Standard Time) which is five hours behind Greenwich Meridian Time; name of station, city, country; identification signal if any. Sign your name at the bottom of the list and furthermore state the type of set used by you to receive these stations. State total No. stations.

# The New Doerle

**6-TUBE BANDSPREAD RECEIVER**  
**Marvelous SENSITIVITY and SELECTIVITY**  
**Only Found in the Higher Priced Models**

The famous Doerle line of receivers are now equipped with the new Octal sockets in which glass and metal tubes are interchangeable. For the first time this quality receiver is available in KIT form for the short wave experimenter who prefers to "build his own."

Uses 6 of the latest hi-gain tubes (6K7G, 6K7G, 6C5G, 6C5G, 6F6G and 5Y3) in a highly efficient and selective circuit, using two tuned stages—electron coupled regenerative detector—POWERFUL 3 stage resistance capacity coupled audio frequency amplifier with power pentode output stage—full wave high voltage rectifier and self contained hum-free power supply. Built-in High Fidelity dynamic speaker capable of handling the entire 3 watts of audio frequency power output of the receiver.

Continuous bandspread over the entire range of 9½ to 625 meters is obtainable due to the use of a special type, multi-colored, airplane dial having 125 to 1 ratio and two pointers. Two knobs are provided and make possible either fast or slow motion tuning. ALL of the AMATEUR and FOREIGN SW BANDS are spread over a generous portion of the tuning dial, thereby simplifying tuning so that even a beginner can operate it to the utmost satisfaction. Entirely free from all traces of backlash.

The entire unit is contained in a large, black crackle finished metal chassis and cabinet of extreme beauty. All controls are mounted on the front panel and all parts are readily accessible. No adjustments whatever are necessary. Nothing to get out of order. Simply plug into your electric light socket and enjoy an evening of short wave thrills and entertainment such as you have never before experienced.

Mechanical specifications: Dimensions are 17½"x8"x8¾". Net weight 23 lbs. Shipping weight 33 lbs. Designed to operate entirely from 100-130 volts, 50 to 60 cycles AC house current. Shipment made same day as order is received. Complete satisfaction guaranteed.

**DOERLE 6-tube AC BANDSPREAD RECEIVER**, completely wired and tested, with set of 6 matched Arcturus tubes, 8 coils for 9½ to 200 meters, cabinet, instructions, and **READY TO OPERATE**. Licensed under RCA and Hazeltine patents. (Specify whether metal or glass tubes desired.)

**DOERLE 6-tube AC SW KIT**, containing all necessary parts, including 8 low loss ribbed coils for 9½ to 200 meters, full size hi-fidelity dynamic speaker, beautiful cabinet, and 4 page instruction booklet (less tubes, Broadcast coils, and unwired) \$17.96  
 6 Arcturus matched tubes \$3.12  
 Broadcast band coils (2) 1.45

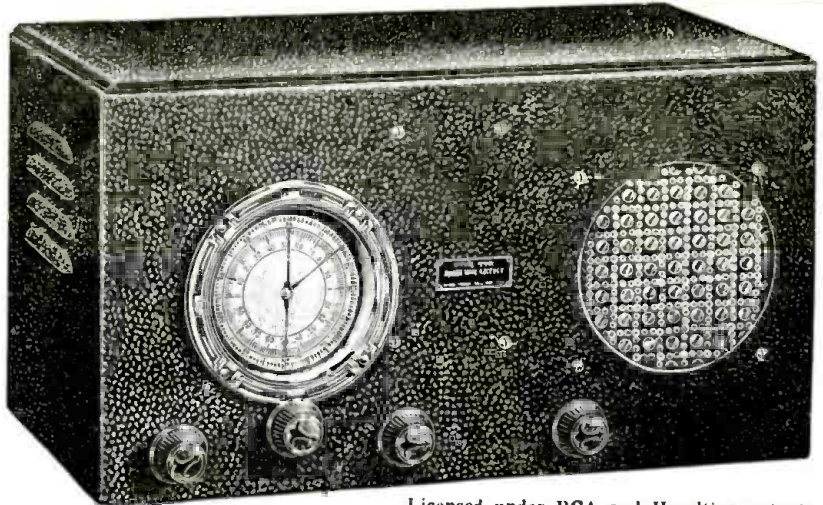

Licensed under RCA and Hazeltine patents

- ★ Continuous bandspread tuning from 9½ to 625 meters.
- ★ An ideal DX receiver for the long distance SW fan or communications receiver for the transmitting amateur.
- ★ Beautiful large, illuminated, dual pointer, multi-colored, airplane type dial of great beauty.
- ★ Operates from either single wire type aerial or noise-free doublet.
- ★ Volume control—stage aligning trimmer—and tone controls.
- ★ Unusually smooth acting regeneration control.
- ★ Headphone jack with speaker cut-off switch.
- ★ Highly efficient, low loss ribbed plug-in coils, are a large factor in the amazing sensitivity and selectivity of this receiver. Coils are of the large 3 winding variety and are color coded for easy identification.

**DOERLE 6-TUBE BATTERY OPERATED RECEIVER**, has same specifications as above except that economical 2 volt type tubes are used and operate entirely from dry batteries. Subtract \$2 from price of electric model (less batteries).

## FREE CATALOG

If you wish to preserve the front cover, COPY the coupon below and mail at once

**GUY STOKELY RADIO CORPORATION** Dept. S-8  
 126 Liberty St., New York City

Attention: Please mail without expense or obligation your catalog of the famous Doerle Receiving Sets, illustrating and fully describing All Electric and Battery models, also reproduction of letters from users in all parts of the country.

I enclose \$..... for which please send me.....  
 (On C.O.D. orders, send 20% deposit.)

Name.....  
 Street Address.....  
 City..... State.....

**GUY STOKELY RADIO CORPORATION, 126 Liberty St., Dept. S-8, New York City**  
 SOLE MANUFACTURERS AND DISTRIBUTORS OF DOERLE SETS

the radio-frequency stage and the detector, until a choice of five methods of coupling and regeneration could be had, all without changing the wiring in the set itself. With the seven-prong tube which was later developed and the use of bakelite tubing, which would make coil-forms out of the bases, my total jumped to ten methods, nine of which are shown here.

### Wiring of Set Remains the Same

With this method the wiring in the set remains the same at all times, with the exception of the .0001 mf. condenser in the plate circuit of figure No. 9. Following is a diagram (A) of all the connections made to the coil socket. Care must be taken to observe the S.P.D.T. switch in the grid circuit, which is turned to position 2 for figures (7), (8) and (9), and to position 1 for all other figures.

In circuit (B) we see the original detector and radio-frequency coupling as used in the "Composite Receiver." With it are shown the coil connections as made to the prongs of the coil form.

Then in figure (1) we see the same cir-

## How To Experiment With New Circuits

(Continued from page 205)

cuit adapted to a seven-prong coil form. The jumper between prongs 2 and 7, you will see by referring to figure (A), connects the cathode into the ground circuit. There is nothing complicated about any of the circuits in the diagrams. They have all been described in past issues of *Short Wave Craft* and all are capable of possible good reception.

### One Chassis Serves Many Circuits

The main purpose of this article is to show that one chassis can serve as the "backbone" of a dozen different receivers, each one being a distinct type. With no extra wiring it is possible to have a different type of circuit for each wavelength. It is then possible to choose the circuit, and the band for which it is suited the best, and use them accordingly. The exceptional performance need not be lost because it is no longer necessary to make one type of re-

ceiver work on all bands.

Perhaps a word should be said about the construction of the coils. In figure (C) we see a phantom view of the coil form and arrangement of the apparatus inside. It is best to install the necessary resistors and condensers in the tube base, before attaching the bakelite tube. If a stiff piece of wire size No. 14 or No. 16 is soldered to each of the prongs internally and left six inches long inside the form it will not be difficult to fasten the connections to the base. For example refer to figure (D). All necessary condensers and resistors used in the coils are the very smallest available, and if properly placed will exert no undesirable capacity effects upon the coil. The coils should be wound about 1¼" from the bottom.

In figures (8) and (9) variable condenser and resistor C1 and R1 respectively are mounted in the head of the coil and project beyond the panel in a panel-mounting arrangement. In each of their circuits they become the "regeneration" control. The usual regeneration controls, R2, in both cases, are set at the point of oscillation and remain fixed.

Please mention **SHORT WAVE CRAFT** when writing advertisers

# HARRISON RADIO COMPANY is pleased to Announce the addition of GERALD D. COLEMAN W8FRC to their sales and technical staff--

G. D. C.  
12 West Broadway  
New York, N. Y.  
June 16th, 1936

To Every Reader of S.W.C.,  
I will be glad to give my close attention to all inquiries and orders to the Harrison Radio Co. directed to my attention. If you can't conveniently stop in, do not hesitate to get in touch with me by letter.  
I am grateful for the opportunity to express my thanks to the many readers of Short Wave Craft and to the Harrison Radio Company as well for making possible my continued service to the Radio Amateur.  
Gerald D. Coleman

Gerald D. Coleman with his Amateur Station W8FRC has gained nation-wide renown for his heroic rescue work, via Radio, during the exciting days and nights of the recent Johnstown Flood. His association, now, with the Harrison Radio Co., makes it possible for every reader of S.W.C. to enjoy direct contact with him by availing himself of our free technical service. Your orders and inquiries will have W8FRC's personal attention.

the fact that this device cannot perform wonders in "deposit findings," as is sometimes claimed for the "divining rod" and similar pseudo-scientific devices. The most efficient application of the "radio bomb" can be made when used in cooperation with a mining engineer or a geologist. Since experts of this kind are mostly connected with boring projects, all the conditions for a one-hundred-per-cent utilization of the new invention may be arrived at.

Prospecting by boring is most successful in cases of mineral deposits which are nearly horizontal, or at least not highly inclined. (See Figs. 2 and 3) Beds of such minerals are pierced at a number of points and the depth at which each hole enters the deposits and the thickness of the bed itself can be quite readily ascertained, so that a map can be constructed with some degree of accuracy. Samples of the deposits are secured, also furnishing data for computing the value of the deposit.

The application of the radio bomb makes a number of the very expensive bores superfluous since a character of the underground between the few bores now executed can be surveyed by the radio bomb.

### A Different S-W Survey Scheme

This idea of prospecting or attempting to analyze the mineral and other strata in the ground by means of short waves or other electrical means has been suggested by numerous inventors in the past. One of the methods advocated by more than one of the radio experimenters has been that involving the use of ultra short waves projected by a beam transmitter, using a parabolic reflector, for example. This is caused to project short waves into the ground at a certain angle, and here various reflections or refractions may occur due to mineral or similar deposits in the ground. The reflected waves are supposed to be picked up on one or a series of sensitive receivers located at various points about the field being surveyed.

Another plan made by H. W. Secor for the utilization of ultra short waves in exploring and analyzing the various strata, mineral or other deposits, etc., composing the immediate cross-section of ground in a given location works as follows:

A series of bores are made in a systematic fashion over the area to be surveyed or explored, and a series of measurements are carefully made in a progressive manner across the area of land. (See Figs. 4, 5 and 6) The diminution in strength of the received radio signals, if any, are measured progressively across the field. The transmitter is placed in No. 1 bore on one side of the field and the receiver is lowered into No. 1 bore on the opposite side of the field, for example. Eventually a complete tabulation will be obtained for the measurements across the field; noting where the strength of signal diminishes, this would indicate the presence of a mineral or similar deposit between the transmitting and receiving sets at that particular point. The exact nature of the deposit in any case would have to be checked by making a "test bore" at the indicated spot.

As Mr. Secor pointed out, the short-wave apparatus for carrying out this new method of locating and analyzing mineral deposits (and possibly oil and water as well) is already well-known. Experienced "Hams" or radio amateurs have in their "shack" some sort of field-strength measuring instrument. So here's a chance for the geologist and the "Ham" to get together; maybe a brand new system of mineral locating will result.

### Girl Operators, Attention!

Listen "YL's" and "XYL's"! Why not send the Editor a good photo of your "Rig"—and don't forget yourself. A separate photo of yourself will do, with a "clear" photo of that station! \$5.00 for best "YL" photo.—Editor. See page 649 March issue for details.

## "NOISE SILENCER" • ELIMINATES "MAN-MADE" STATIC!

The noise "Check Valve," a development of James J. Lamb, editor of QST, has been acclaimed as one of the greatest discoveries in radio! Attached to any superheterodyne receiver, it eliminates noises caused by any sparking motors (oil burners, vacuum cleaners, fans, etc.) automobile ignition, high tension lines, dial telephones, etc. Reduction of noise as high as 1000 to 1 in power on sharp interference!

Just attach the noise silencer unit to rear or side of your receiver and make three simple "tip" connections. A few minor adjustments as outlined in the instructions and you enjoy real noise free reception. Works on all wave-lengths. The louder the interference the easier it is to completely cut it out!

HARRISON presents a very compact version by William Green, of this amazing invention as described in QST and other magazines. A neat metal case measuring only 2 1/2" x 1 1/2" houses all necessary parts and the three tubes. Draws only negligible current from receiver. Has self-contained filament supply.

For SUPERHETERODYNE Receivers only. (Both BCL, SWL, and Amateur.) Mention make and model of set when ordering so we may supply the correct pronged attachment plug.

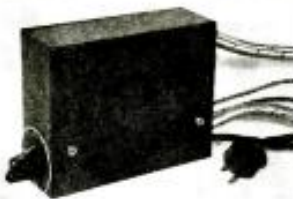

**COMPLETE KIT \$3.85**  
of all necessary first grade parts, crystal finished cabinet with all holes drilled, and complete instructions, less tubes, wired.  
Three 5Y4 vacuum metal tubes..... \$2.50  
Completely wired, ready to attach and operate, with tubes..... \$8.55

**HARRISON RADIO COMPANY** 12 WEST BROADWAY NEW YORK Dept. C-8 N. Y.

**SUPER SKYRIDER**  
**SKY BUDDY**  
**SUPER SEVEN**  
**ULTRA SKYRIDER**

America's leading short wave receivers—rulers of the air! No other communication receivers offer you the same advantages and convenience at the same moderate prices that anyone can afford. Metal tubes. Iron core I.F. coils. No plug-in coils. Micro-Venturi Diaphragm—Electro-Mechanical band spread—Built-in Power Packs and Speakers. See these amazing receivers at your jobbers today or write

COMMUNICATION DIVISION  
**THE HALLICRAFTERS, INC.**  
MARION, INDIANA

UNCONDITIONAL GUARANTEE ON ALL OUR RADIO SUPPLIES

**UNCLE DAVE'S**  
RADIO SHACK  
330 BROADWAY-ALBANY, N. Y., U.S.A.

PEERLESS AC dynamic speakers 9"	\$2.65
PEERLESS DC dynamic speakers 9"	\$2.00
9"	\$1.50
12"	1.75
14"	2.25
PEERLESS I-tube DC receiver kit, with coils	1.75
tube	\$1.75
Wired & tested	.35
tube	.39
CG-1162 Navy 5 watt tubes, 12 for	1.00

Let us give you an allowance on your old receiver towards a new HRO. HME. or S.P. PRO, etc.

Cable Address "Uncle Dave"  
Long Distance Phone 4-5746  
Include 20% deposit with c.o.d. orders  
Prices F.O.B. Albany Foreign Trade Solicited  
Send for new Ham Catalogue—just out!

**GOOD RESULTS Demand GOOD INSTRUMENTS**

TRIPLETT manufactures a complete line of electrical instruments for radio, electrical and general industrial purposes, both standard and custom built—For better short wave work, write for catalogue.

Model 525  
D. C. Portable  
Accuracy within 1%

Triplet Electrical Instrument Co.  
288 Harmon Drive  
Bluffton, Ohio

**TRIPLET**  
Precision  
ELECTRICAL INSTRUMENTS

## Short-Wave Radio Bomb Locates Mineral Deposits

(Continued from page 200)

tures as they are found in the vicinity of the bore to be surveyed, since the character of the underground strata and its "mixture" changes greatly in different parts of the country.

By means of a thermo-couple the plate current variations are sent, as the diagram indicates, to a galvanometer (millivoltmeter) which shows on its specially calibrated scale the kind of material which surrounds the bore.

### Radio Amateur Could Build the S-W Exploring Apparatus

It should not be very difficult for an experienced radio amateur to construct such a prospecting device, especially if he has some knowledge of the design and construction of small transmitters operating in the range between 9 and 10 meters. And no difficulties are to be expected in the calibration of the galvanometer (milli-volt or ammeter), since placing different materials between the casing and attached antenna will do the trick. If we consider that no great difficulties are involved in the construction of such a device, and the interesting experiments which can be executed with the new invention, one should expect that many amateurs will try to utilize it as a lucrative hobby.

In former times a great many borings were necessary to obtain proper surveys, especially in those cases where irregular and steeply inclined deposits of small areas had to be sounded. Now only a few will be necessary, and the space between the few bores executed will be searched by the ultra short wave apparatus more exactly and expeditiously. If we keep in mind that sometimes tremendously deep shafts have had to be bored for a single geological survey, at enormous cost (for example a bore near Pittsburgh, Pa., 5,532 ft., and at Wheeling, W. Va., one nearly 5,000 feet), and that now instead of many bores as formerly necessary, a few bores only may do the trick with this new system, the importance of the new invention to the art of mining engineering is beyond any doubt.

An important point to be mentioned is

Please mention SHORT WAVE CRAFT when writing advertisers



**Eilen**  
**RX-14**  
6-tube Bandspread Receiver  
8 1/2 to 600 meters

OUR LARGEST, FINEST, AND MOST SENSITIVE SHORT WAVE RECEIVER which WILL satisfy even the most discriminating SW fan. Uses two 6D6, two 76, and 12 1/2 electron coupled screen grid regenerative detector, POWERFUL 3 stage audio amplifier, ILLUMINATED full wave rectifier and built-in power supply. Operates from your AC house current. POWERFUL hi-quality audio system delivering 3 watts of power to the built-in hi-fidelity dynamic loudspeaker—automatic headphone jack—smooth regeneration and volume controls—connections for doublet or single wire antenna—black shrivel finished metal chassis and cabinet of extreme beauty—selectivity, sensitivity, and volume that will amaze you. PRICE, complete with 6 tubes, 8 coils, \$21.95 cabinet, speaker, wired, less B.C. coils, ready to use.

and one 5Y3 hi-gain tubes as TUNED RF amplifier, TUNED electron coupled screen grid regenerative detector, POWERFUL 3 stage audio amplifier, ILLUMINATED full wave rectifier and built-in power supply. Operates from your AC house current. POWERFUL hi-quality audio system delivering 3 watts of power to the built-in hi-fidelity dynamic loudspeaker—automatic headphone jack—smooth regeneration and volume controls—connections for doublet or single wire antenna—black shrivel finished metal chassis and cabinet of extreme beauty—selectivity, sensitivity, and volume that will amaze you. PRICE, complete with 6 tubes, 8 coils, \$21.95 cabinet, speaker, wired, less B.C. coils, ready to use.

(2 Broadcast band coils, extra \$1.15)

**RX-14 KIT \$14.95**  
of necessary parts, including 8 low-loss coils for 8 1/2 to 200 meters, and simple instructions, (less cabinet, tubes, and B.C. coils, un-wired) \$11.95  
Beautiful, heavy steel cabinet, extra \$2.50  
6 MATCHED ARCTURUS tubes \$2.95  
**SPECIAL**  
Complete kit, cabinet, tubes, speaker, and detailed instructions, less B.C. coils, un-wired \$19.95  
Labor for wiring and testing, extra 2.00  
Broadcast band coils (2), extra 1.45

**IF METAL TUBES** are preferred over the glass type, add \$1 to price.

**RX-14B:** Battery model of RX-14. Subtract \$1 from above price (less batteries).

**AMATEURS:**  
Model RX-14-AB CONDUCTIONS RECEIVER has same specifications as RX-14 except that it is equipped with special coils for the 20-40-80-160 M bands which spread these bands over a generous portion of the tuning dial. Also equipped with plate voltage cut-off switch for use during transmitting periods. An ideal receiver for amateur communications work. Add \$1 to price of RX-14.

**Eilen**  
**BS-5**  
5-Tube Band switch Receiver



9 1/2 to 600 meters  
A powerful, sensitive, and selective SW receiver covering the entire wavelength span of 9 1/2 to 600 meters in 5 steps. NO PLUG-IN COILS are used. Simply turn the waveband selector switch and enjoy reception on any wavelength within this range.

Uses two 6D6, one 76, one 43, and one 25Z5 tubes as RF amplifier, electron coupled screen grid regenerative detector, powerful 2 stage audio amplifier with pentode output stage, rectifier, and complete built-in power supply.

Illuminated vernier dial—automatic tuning control—automatic headphone jack—extremely smooth acting controls—operates from your AC or DC house current—beautiful, heavy, black shrivel finish chassis and cabinet.

DELIVERS GREAT LOUDSPEAKER VOLUME ON THE GREAT MAJORITY OF SHORT WAVE FOREIGN STATIONS UNDER FAIR CONDITIONS.

Uses two 6D6, one 76, one 43, and one 25Z5 tubes as RF amplifier, electron coupled screen grid regenerative detector, powerful 2 stage audio amplifier with pentode output stage, rectifier, and complete built-in power supply.

Illuminated vernier dial—automatic tuning control—automatic headphone jack—extremely smooth acting controls—operates from your AC or DC house current—beautiful, heavy, black shrivel finish chassis and cabinet.

DELIVERS GREAT LOUDSPEAKER VOLUME ON THE GREAT MAJORITY OF SHORT WAVE FOREIGN STATIONS UNDER FAIR CONDITIONS.

PRICE, complete with 5 tubes, cabinet, speaker, wired, ready to use \$16.95

**BS-5 KIT, of necessary parts, including speaker and detailed instructions, less tubes, cabinet, unwired \$10.95**  
Beautiful, black shrivel finish metal cabinet, extra \$2.00  
Set of 5 MATCHED Arcturus tubes, extra, 2.50  
**SPECIAL:** Complete kit, cabinet, tubes and instructions, unwired \$14.95  
Labor for wiring and testing, extra \$2.00 (if metal tubes are preferred to glass type, add \$1)

**AMATEURS:**  
Model BS-5-AB has same specifications as BS-5 except that it has special bandspread circuit for 20-40-80-160 M bands and is equipped with plate voltage cut-off switch. Add \$1.00 to above price.

**Eilen HF-19 One-Tube Transceiver**  
5 to 10 meters

A masterpiece in simplicity! An unequalled value for the experimenter who is interested in an inexpensive transceiver which will enable him to maintain reliable 2 way communication with a friend over distances up to 5 or 10 miles. So simple that even a beginner may readily obtain remarkable results with it. Uses one type 19 (twin 2 in 1 tube) in special circuit producing great volume and signal strength. Operates from 2 dry cells and 90 to 135 volts of B battery.



**HF-19 TRANSCEIVER KIT, of necessary parts, and simple instructions, less cabinet, tube, microphone, unwired \$3.95**  
Beautiful crackle finish cabinet, extra \$1.25  
Type 19 tube, extra .65  
Wired and tested, extra 1.50  
Microphone for above, extra 1.95

**Eilen 6C Short Wave 4-Tube Receiver**  
A Giant in Performance

FULL 6 TUBE PERFORMANCE—POWERFUL 3 STAGE AUDIO AMPLIFIER which takes the guesswork out of so-called "loudspeaker reception."  
Uses 6D6-6E7 twin 2 in 1-76-12A7 twin 2 in 1 hi-gain tubes as RF amplifier, screen grid regenerative detector, POWERFUL 3 stage audio amplifier with pentode output stage, rectifier and built-in hum-free power supply. Completely self-contained. Nothing else required. Operates entirely from 105 to 130 volt AC or DC light socket.



**BAND SPREAD TUNING—smooth** regeneration control—built-in high quality loudspeaker—automatic headphone jack—large illuminated airplane type vernier dial—large 3 winding low-loss inductances—selectivity, sensitivity, and volume that will amaze you. Heavy black shrivel finish metal chassis and cabinet. Must be seen to be appreciated. Satisfied owners report dozens of foreign stations on loudspeaker. You may do the same under the proper conditions. ORDER YOURS TODAY! YOU'LL NEVER REGRET IT!

6C kit (unwired), of all necessary parts, 4 coils for 9 1/2 to 200 meters and instructions (less cabinet, tubes, speaker, and B.C. coils) \$7.45  
Beautiful cabinet 1.25  
4 matched Arcturus tubes 4.15  
Special loudspeaker 1.45  
Broadcast band coils (2) 1.25  
Special: complete kit, cabinet, 4 tubes, loudspeaker, and one B.C. coil, unwired \$12.45  
Labor for wiring and testing, extra 1.00

**Eilen Two-Tube SHORT WAVE Radio Only \$3.00**  
less tubes, phones, unwired



A REAL, powerful 2 tube short wave set that readily brings in amateurs, police calls, broadcast stations, experimental and foreign stations under fair conditions. THE WORLD AT YOUR DOOR!  
A DEPENDABLE RECEIVER which is guaranteed to give RESULTS. Operates entirely from the AC or DC house current. Simple to build and easy to operate. Beautiful, black shrivel finished cabinet and instructions furnished. Wavelength range 10 to 600 meters.

**TWO TUBE BATTERY SET, less tubes, phones, batteries, unwired \$2.00**  
Kits wired, extra \$0.75. Tubes, each \$0.75  
Cannonball double headphones \$1.25

**FREE**  
Large, illustrated 20 page catalogue of short wave receiver kits, transmitters, and accessories. Send stamp to cover postage and handling charges.

**AMATEURS:** Model 6C-AB has same specifications as 6C except that it has special tuning circuit and coils for spreading out the 20-40-80-160 M bands over 80% of dial scale—plate voltage cutoff switch. Add \$1 to price of 6C.

**EILEN RADIO LABORATORIES, Dept. SC 8, 136 LIBERTY STREET, NEW YORK, N. Y.**

**Super-Regenerator**  
(Continued from page 207)

ing duplex, the coupling may be reduced considerably without affecting the tuning range of the receiver. Also duplex operation is facilitated with this method of coupling. The size of the coupling condenser in this case is much greater than if we were coupling to the grid directly. A 15 mmf. variable proved to be the most satisfactory.

Referring to the diagram we find that plenty of mica by-passing condensers are employed. Each has a capacity of .0001 mf. where they are used in the R.F. circuits. We found that the midget size moulded condensers gave best results and were most effective.

The audio amplifier consists of a triode first stage and a pentode as the second stage. Both are transformer-coupled. The first tube may be either a 37 or a 76 and the second one may be either a 41 or a 42. The 42 provides slightly greater volume but there is sufficient with the 41; so much in

fact, that the audio gain control in the grid circuit is necessary. A further improvement suggested by one of the Hams who built this set was a tone control. This is shown in the diagram for the benefit of anyone wishing to make this improvement, but it was not found necessary in the original receiver.

The entire set is built in a National SW3 cabinet, which makes a very convenient housing and proved to be just the right size. A separate power-supply is needed and should deliver approximately 250 volts and at least 50 milliamperes. If the reader wishes to combine the receiver and power-supply in the same cabinet, a larger one will be necessary. The combined unit should be carefully laid out so that the detector picks up no hum from the power unit wiring. Unused filament windings have been found to cause a tunable hum; so watch for this in your power supply.

As a further stamp of approval this set has been recommended by the Garden City Radio Club as a model to be used in reporting the famous Long Island Sound Yacht Races this summer.

**Beginner's 2-Tube S-W Receiver**  
(Continued from page 216)

Examination of the circuit diagram reveals the use of two type 37 tubes. One of these functions as a half-wave rectifier tube, the grid and plate terminals being tied together at the socket base, and the other as a highly efficient regenerative detector, which is capable of picking up even the faintest of signals.

The aerial may be any length of wire from 30 to 100 feet in overall length. No ground connection is required. Tuning procedure is the same as in any standard regenerative receiver. Using this model in New York City, the author has had no difficulty in experiencing nightly reception from Europe, South America, and numerous North American stations.

This article has been prepared from data supplied by courtesy of Eilen Radio Laboratories.

Please mention SHORT WAVE CRAFT when writing advertisers

# PROMPT DELIVERY ASSURED

on following models

R.C.A. MODEL ACR-175	SUPER-SKYRIDER	MARINE TRANSMITTERS
NATIONAL HRO	ULTRA-SKYRIDER	Write for details and illustrated literature on the complete line of MARINE Transmitters for the "Amateur" ranging in power from 20 to 1000 watts.
NATIONAL HRO Jr.	SKY BUDDY	
PATERSON PR-16	SARGENT 10, 12, 20	
RME-69		

## RECEIVERS SHIPPED PREPAID

If full purchase price accompanies order except where factory regulations prohibit

ALSO AVAILABLE ON OUR

## NO DOWN PAYMENT

20-MONTHS-TO-PAY PLAN

NOW! All Standard receivers and MARINE Transmitters available on the new MARINE RADIO BUDGET PLAN . . . At standard AMATEUR NET PRICES, plus small carrying charge. Write for full details.

# MARINE RADIO COMPANY

62 Lispenard Street, (Formerly Richmond Hill, N. Y.) New York, N. Y.

## Short Waves Directed Hindenburg to America

(Continued from page 197)

Zeppelin Co., Friedrichshafen, Germany) inspected the airship while it was moored at the Naval-Air-Base at Lakehurst, N.J. In an interview with the radio operators, the author was told that the *long wave* set is already considered only as *auxiliary* equipment, and they prefer the use of the 200 watt *short-wave* transmitter which covers a waverange from 17-70 meters and embraces the entire globe, even at times when the long wave signals did not come through because of unfavorable atmospheric conditions.

### Receivers Use Same Antennas As Transmitters

The receivers operate from the transmitter antennas, but a timing device consisting of intricate relays takes care that an interval of about 2 seconds passes before the receivers are connected with the antenna, after the transmitters have been in operation. These relays are controlled by the transmitter key or microphone current. These relays have *clear-out* and *reception* contacts which are connected with a clever device which changes the release time at will.

At the moment the transmitter stops operating the *slow-release* part of the relay goes into action, and in a certain time—adjustable between ½ second and 50 seconds—the antenna is switched from the transmitter to the receiver. In case the operator touches the key again the antenna is instantaneously connected with the transmitter.

### S-W "Homing" Set

Another interesting part of the Zepp's radio equipment is the direction finder or "homing device" which operates in a well-known manner in connection with a vertical loop antenna. Such a homing device is most sensitive to signals coming from transmitters in the direction of its axis, and very low in sensitivity to signals coming at right-angles to this axis. The loop antenna may be rotated until a maximum or minimum signal strength is obtained. The loop position may then be read from an azimuth circle on the base of the control handle, and this indicates the relative bearing of the Zepp's position to the station.

### "Blind-Landing" Device Uses Short Waves

In addition to this direction-finder equipment there are also provided two *blind-landing* receivers which operate upon small indicator instruments as shown in Fig. 1. One of these indicators is installed on the table of the navigation room in the control gondola, and the other is found at the right side of the steering wheel in the prow of the gondola. Both blind landings receivers are connected with a single loop antenna and an auxiliary antenna, in the form of straight single wire stretched beneath the airship body (see Fig. 2).

### Landing in a Fog by Short Waves

In case the airship arrives at the airport of destination in very foggy weather, three small short-wave transmitters installed in automobiles are put into operation. They are placed at three points of the landing field in a triangular formation. These points are selected in such a way that the landing crew is located in the center of the triangle (see Fig. 3).

When the airship approaches the center of the triangle both blind-landing receivers, and also the receiver of the direction-finder (which are connected together in the form of a bridge circuit) have an output of similar magnitude. At the moment the Zepp is exactly above the center of the triangle, the output current of the three receivers is "in balance" and the small indicator instruments mentioned above, which showed until then "left" or "right," goes back into "zero" position.

The elevation is checked from the usual altimeters or altitude gauges.

## CALL LETTERS

to dress up your station. Beautifully mounted on large glass panel and attractively framed. Letters of embossed real gold or silver. Mounted complete and sent postpaid, only a letter. Specify gold or silver.—Order direct, enclosing remittance, or sent C.O.D.

**25c**

G. F. SIGN CO. 1505 N. Paulina St., Chicago, Ill.

## PATENTS — TRADE MARKS

All inventions submitted held confidential and given personal attention by members of the firm.

Form "Evidence of Conception" and instructions

"How to Establish Your Rights"—Free

LANCASTER, ALLWINE & ROMMEL. PATENT LAW OFFICES

475 Bowen Bldg. Washington, D. C.

We offer you this Magazine Holder ABSOLUTELY FREE

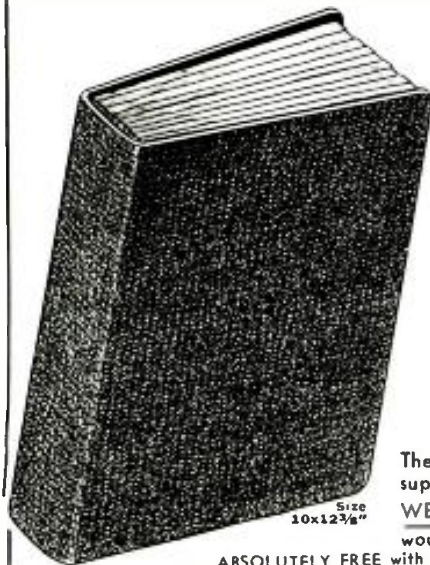

# SAVE MONEY! SPACE! TIME!

and your TEMPER!

by placing all your magazines in this holder and keep your "shack" or home tidy.

Instead of having your magazines scattered all over the house—on chairs, tables, shelves or on the floor and have them torn or soiled, you will always be able to find your favorite magazine when you need it.

These holders are of ample size to hold a year's supply of magazines.

WE DO NOT SELL THESE HOLDERS—although it

would readily sell for \$1.00. This holder is offered

ABSOLUTELY FREE with one year's subscription to SHORT WAVE CRAFT for the regular price of \$2.50 a year (foreign countries \$3.00) or if you prefer we will furnish this holder with twelve back numbers for \$1.50.

We can supply only the following back numbers: Dec. 1930; Feb., April, June, Oct. 1931; Sept. 1932; Sept., Nov., Dec. 1933; Jan., Feb., Mar., April, May June, July, Aug., Sept., Oct., 1934; 1935—All issues; 1936—All issues to date.

The holder is made of the highest grade material obtainable. Two very HEAVY cardboards are covered with genuine DuPont black grained leatheroid, with a flexible backbone.

We have only a limited number of these holders and we would suggest prompt action.

### SHORT WAVE CRAFT

99 Hudson St. New York, N. Y.

Short Wave Craft 99 Hudson Street New York, N. Y. SW-8

Gentlemen:  I enclose \$2.50 (Foreign \$3.00) for one year's subscription to SHORT WAVE CRAFT, including the Magazine Holder FREE.

I enclose \$1.50 for twelve back numbers of SHORT WAVE CRAFT, including the Magazine Holder FREE. (Please attach to coupon list of back numbers desired.)

Name .....

Address .....

City ..... State .....

Please mention SHORT WAVE CRAFT when writing advertisers



## Electric Wave Guides

(Continued from page 198)

So far as is now known, no experimental work was attempted at that early date. As often happens in science these principles were independently discovered by others. In particular, a group of workers in Germany studied this problem and published several papers. They were Hondros and Debye in 1910, Zahn in 1916 and Schriever in 1920. Also our own J. R. Carson in 1924 and R. V. L. Hartley in 1931 gave thought to this problem. Both Zahn and Schriever did a small amount of experimental work but it related mainly to the form of wave guide consisting of insulation alone, and dealt with just one of the many types of waves that may be propagated. The published literature indicates that their work was dropped at that point.

In 1931 the author resumed some experimental work on this subject, which he had started in 1920. This has now been expanded slightly and moved to our Holmdel Laboratory where long wave guides may be constructed. Some details have been given in the April, 1926, issue of the Bell System Technical Journal. Throughout this experimental research there has been considerable work done by members of the mathematical groups, notably by J. R. Carson, Sally P. Mead, and S. A. Schelkunoff, who also have a paper in the Bell System Technical Journal for April. Sometimes experiment has suggested analysis. Sometimes analysis has suggested experiment. As in military operations so in experimental research, greatest progress is made when the efforts of line and staff are complimentary.

The analytical work of Rayleigh and others has now been greatly amplified. The extensions which have been added to the theory include calculations of characteristic impedance, attenuation, and inductive effects into neighboring wave guides, and particularly the discovery that, theoretically at least, one of the many waves that may be transmitted through a hollow pipe becomes progressively less attenuated as its frequency is raised. This remarkable property appears altogether unique in the field of electrical transmission.

These electric waves that are guided through hollow pipes and dielectric rods are moving configurations of electric and magnetic fields. Mathematical theory indicates that in cylindrical guides these two fields may be associated in many different ways to provide a wide range of types of waves. Four of these are shown in Figure 1. They may be generated by any source of sufficiently high frequency, such as a Barkhausen or a magnetron oscillator. To set up any particular type of wave it is necessary, of course, to provide an appropriate launching mechanism. If the  $E_z$  wave is desired, the source may be connected between the outside shell of the guide and a rather large central disc perpendicular to the principal axis. For  $H_z$  waves the source is connected between diametrically opposite points on the inside of the pipe.

Wave guides behave somewhat like wire lines in that they have a definite characteristic impedance and a definite attenuation. Also waves travel through them with a velocity that may be predicted with considerable accuracy. The calculated attenuations of the four principal waves are of particular interest. They are shown in Figure 2 for the special case of a five-inch hollow copper pipe.

It will be noted that all waves suffer infinite attenuation at or below certain critical frequencies, and that with an increase in frequency this attenuation decreases very rapidly. For three of the types of waves it approaches a minimum, and then increases for higher frequencies. For the wave that has been designated as  $H_z$ , this attenuation appears to decrease indefinitely with the increase of frequency.

Not all of the calculated characteristics of wave guides have yet been verified experimentally. In particular, no informa-

# An Ideal Receiver!



## The Hammarlund "Super Pro"

IN the nation's leading research laboratories, on the air fields, in "ham" shacks, on scientific expeditions, in naval and war departments, coast-to-coast broadcast systems, foreign commercial and government services—everywhere—where the most exacting equipment must be used, Hammarlund "Super Pros" have been unanimously approved and promptly installed! "Super Pros" receive such decided acclamation, for they have every grand, important feature demanded by experts—truly the "ideal receiver." One such feature is the electrostatically shielded input. Then there is that uncanny, exclusive Hammarlund five-band switch, remarkably positive and smooth in action. The unique variable selectivity system affords continuous variation from 1/3 to over 3 times critical coupling. Another fea-

ture is the special 12-gang band spread condenser. That cleverly designed "Super-Pro" crystal unit permits selectivity from a knife-like point for C.W. to a wider degree for practical phone reception. And there are dozens of other outstanding features winning new admiration every moment. The "Super-Pro" reaches new performance standards that you've always wanted! The complete story of this "ideal instrument" appears in a profusely illustrated bulletin. Write for your copy today!

### MAIL COUPON FOR FULL DETAILS!

HAMMARLUND MFG. CO., Inc. SW-4  
424-438 W. 33rd St., New York  
 Check here for complete data on the new Hammarlund "Super Pro."  
 Check here for 1936 Hammarlund General Catalog.

Name \_\_\_\_\_

Address \_\_\_\_\_

## HAMMARLUND'S 25<sup>TH</sup> YEAR

### HANDY MIDGET Electrolytics



Series GLS 1" dia. can units half height of former units (to save space) or twice capacity for given size (for better filtering). ● Inverted mounting. Color-coded leads. ● In 200 and 450 v. working ratings. Several capacities. And inexpensive. ● Send for catalog.

# AEROVOX

CORPORATION

72 Washington St., Brooklyn, N.Y.

### CORNELL-DUBILIER Quality Moulded Mica X-Mitting Condensers



The finest made—C.D. moulded mica Type 4 and 9 mica x-mitting condensers are used extensively in aircraft and marine applications where dependability in operation is of utmost importance. Available in 1,000, 2,500 and 5,000 volt ratings.

For complete capacity and voltage range send for catalog No. 128 free on request. These and others of the complete C-D line of capacitors are available at all Cornell-Dubilier authorized distributors.

MICA • DYKANOL • PAPER WET & DRY ELECTROLYTICS

CORNELL-DUBILIER CORPORATION

4376 BRONX BOULEVARD NEW YORK

Please mention SHORT WAVE CRAFT when writing advertisers

# THE RIGCHECKER



## For Bigger and Better Carriers

Designed by A. J. Haynes as an all-purpose instrument for the transmitting station; it is almost the answer to the Ham's prayer—"Oh Lord, give me a gadget that does everything."

Here are some of its more important uses:—

1. Field Strength Meter.
2. Over Modulation or Frequency Shift Indicator.
3. Wave Meter; Seven separate coils; one for each amateur band.
4. Vacuum Tube Voltmeter;—0-17, 0-100 Volts; A.F. or R.F. with direct linear scale reading.
5. D.C. Voltmeter; 0-10, 0-100, 0-1000 Volts.
6. Monitor;—Voice Quality, Line Hum, Key Clicks, etc.
7. Receiver Tuning and Signal Strength Indicator.
8. 0-1 Milliammeter;—May be used separately with or without variable shunt or fixed series resistors.

In fact, here combined for the first time in the Haynes RigChecker, is everything you need to adjust your transmitter to its maximum efficiency and keep it there.

The Haynes RigChecker may be purchased from any of the following radio concerns:—

- AKRON, OHIO  
Akron Radio Parts Co., Inc., 889 South Main St.
- ALBANY, N.Y.  
Uncle Dave's Radio Shack, 356 Broadway
- ATLANTA, GA.  
Wholesale Radio Service Co., 430 W. Peachtree St., N.W.
- BUTLER, MO.  
Henry Radio Shop, 211-215 N. Main
- CHICAGO, ILL.  
Wholesale Radio Service Co., 901 W. Jackson Blvd.
- MILWAUKEE, WIS.  
Radio Parts Co., Inc., 332 West State St.
- NEWARK, N.J.  
Wholesale Radio Service Co., 219 Central Ave.
- NEW YORK, N.Y.  
Comet Radio Corp., 65 Cortlandt St.  
Gross Radio, Inc., 51 Vesey Street  
Harrison Radio Co., 12 West Broadway  
Harvey's Radio Shop, 103 W. 43rd St.  
Leeds, 45 Vesey Street  
Sun Radio Company, 227 Fulton Street  
Wholesale Radio Service Co., 100 Sixth Ave.
- PHILADELPHIA, PA.  
M. & H. Sporting Goods Co., 512 Market St.  
Radio Electric Service Company, N.E. Cor. 7th & Arch Sts.
- SAN FRANCISCO, CALIF.  
Offenbach Electric Co., Ltd., 1452 Market St.
- SCHENECTADY, N.Y.  
M. Schwartz & Son, 710-712 Broadway
- SEATTLE, WASH.  
Seattle Radio Supply, Inc., 2319 2nd St.

The Haynes RigChecker complete with self-contained tube, batteries, seven plug-in coils, resistors, etc., ready for use; Net price to amateurs ..... \$17.00

FREE on request:—descriptive circular and instructions for use.

Order from your dealer. If he has none in stock and will not order one for you, please communicate with us and we will have one sent to you by the nearest dealer or direct.

**Radio Constructors Laboratories**  
Dept. S, 136 Liberty St., Export Dept. 105 Hudson St.  
New York, N.Y.

tion is yet available on the very interesting  $H_0$  wave except near cut-off. At present, the author, together with A. E. Bowen, A. P. King, and J. F. Hargreaves, is working at the Holmdel Radio Laboratory measuring the attenuations. For this purpose two hollow copper pipes are used, which are four inches and six inches in diameter and 1250 feet long. These pipes are shown in one of the photos.

In much the same way that a pair of



Some of the experimental apparatus employed for wave-guide transmission.

wires may resonate to waves traveling along their length, or an air column may resonate to certain sound waves, so may a short section of wave guide be made to resonate electrically to the frequencies which it is able to propagate. In its role as resonator it behaves as if it were a coil and condenser, sometimes in series with an electromotive force, and sometimes in parallel. These resonance effects are very pronounced and may be simply demonstrated by a cylindrical chamber such as that shown in Figure 3.

The open end of a guide may be made to radiate wave power much the same as sound waves issue from a pipe. To enhance this effect the pipe may be expanded into a cone, thus producing an electrical horn. Tests show that it may function much the same as an acoustical horn, and accordingly may be used as an efficient radiating load for the generator to which it is connected.

The question naturally arises as to what use wave guides may be put. This is a difficult question at this early day. Wave guides have definite limitations. The diameter of the hollow pipe that may be used is directly proportional to the wavelength. For a pipe that is at all convenient in size, the frequencies are the highest that have yet been tried out for radio. It is true that the diameter of pipe might be reduced if it could be filled with a suitable insulator. At this point we are met with a conflicting difficulty of producing at reasonable cost the necessary medium that will incorporate high dielectric constant with sufficiently low losses. It is true too that low attenuation could probably be had with much smaller pipes by the use of  $H_0$  waves, but this calls for an even higher range of frequencies. For long-distance transmission, the situation is that the art at these extreme fre-

quencies is not yet at a point which permits a satisfactory evaluation of practical use. For transmission over very short distances, however, or for use as projectors of electric waves, or as selective elements under certain conditions, the use of wave guides has definite possibilities.—*Courtesy Bell Laboratories Record.*

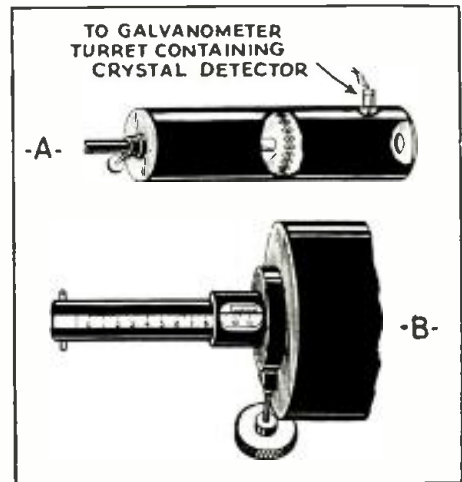

Fig. 3—One form of resonant chamber used in connection with wave-guide transmission.

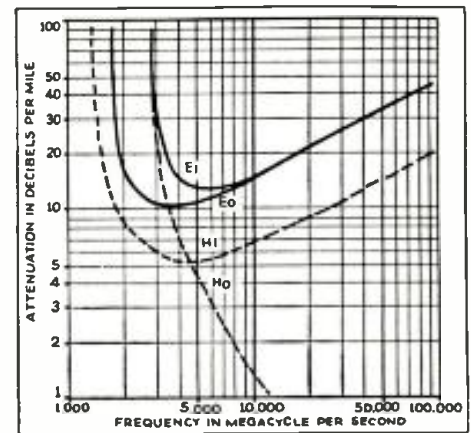

Fig. 2—Attenuation characteristics for four types of wave-guide transmission.

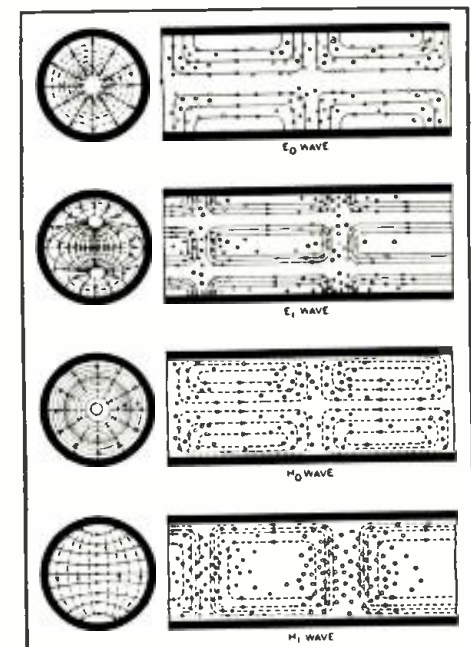

Fig. 1—Schematic reproduction of electric and magnetic fields for four types of wave guide transmission.

## WAKE UP! FELLOWS!

\$20.00 Prize Monthly for Best Set

● THE editors are looking for "new" receiving circuits—from 1 to 5 tubes preferably. A \$20.00 monthly prize will be awarded to the best short-wave receiver submitted. The closing date for each contest is 75 days preceding date of issue (July 15 for the October issue, etc.) In the event of a tie, an equal prize will be given to each contestant so tying. Address all entries to: Editor, SHORT WAVE CRAFT, 99 Hudson St., New York City.

Please mention SHORT WAVE CRAFT when writing advertisers

## "Queen Mary" Uses 32 Different Wave-Lengths

(Continued from page 202)

Mary's" radio station is comparable in equipment to that of the largest and most modern land stations and, in fact, is operated on quite similar lines.

Not only is there ship-to-shore radio-telephone service for the passengers, but the equipment is duplicated, so that it is possible for two passengers to speak simultaneously, in one case to a friend in New

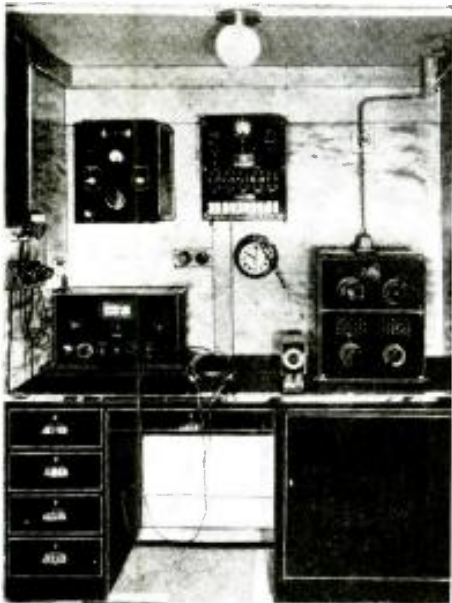

Photos courtesy Int'l Telephone and Telg. Corp.

The emergency radio equipment on the "Queen Mary," comprising transmitter—receiver—and storage battery. This equipment is entirely independent of the ship's electrical power supply, and has a range of at least 500 miles. It is, in fact, of the same power and type as that usually installed as the main equipment of the average ship.

York, and in the other to someone in London or Paris. Radiotelephone booths are provided in suitable positions about the ship, but the ship-to-shore telephone can also be hooked up with any of the 500 staterooms on the telephone system of the ship, depending on the preference of the passenger making or receiving a call. By means of the "Queen Mary's" powerful radio-telephone, passengers will be able to converse with friends practically anywhere in the civilized world.

The receiving station of the "Queen Mary" is situated on the boat deck, between the first and second funnels, and the control of the entire radio equipment is concentrated at this point. This structure occupies an area of approximately 800 square feet and within it is found eight operating positions, the radio-telephone exchange, the emergency installation and the chief accepting office for the radiotelegrams of passengers.

Typewriters and high-speed machines for transmission and reception are provided for the handling of messages, and telephones are installed for communication with the officers' bridge and other important positions. A particularly interesting feature of the radio installation is the remote control of the transmitting station by the staff stationed in the receiving station.

The transmitting station is located 350 feet further aft than the receiving station, to permit of simultaneous transmission and reception of signals without mutual interference. The transmitting station contains four large transmitters, each of which is capable of maintaining continuous communication with both sides of the Atlantic throughout the voyage.

Each of the operators on duty in the

## R-S-R Jr. 3-Tube Communication Receiver 5-555 METERS

A new development of the famous HAYNES R-S-R at an unheard of price for this class of receiver. We have priced this set at an absolute direct-sale minimum as a special Summer feature.

The R-S-R Jr. was designed as an amateur communication receiver; but it is equally as effective on long distance, short wave, and broadcast reception. It's selectivity and regenerative gain amazes even the hard boiled "old-timers". Using two 76 Super-Triodes and an 80 rectifier it will operate a speaker on good signals.



### FULL B-A-N-D-S-P-R-E-A-D

- Separate tank and bandspread condensers.
  - Super-Regeneration on 5 & 10 meter bands.
  - High voltage A.C. transformer and 80 rectifier power supply built-in.
  - Straight antenna or doublet connections with front panel variable antenna coupling.
  - Standby switch for communication work.
  - All coils are included, giving full coverage from 15 to 555 meters; also 5 & 10 meter bands.
- Complete kit, including coils from 5 to 555 meters; drilled panel, chassis, power supply, etc., less tubes, cabinet, unwired.....\$7.60
- Crystalized metal cabinet.....1.00  
Kit of three matched tubes.....1.25  
Assembled, wired and tested.....2.35

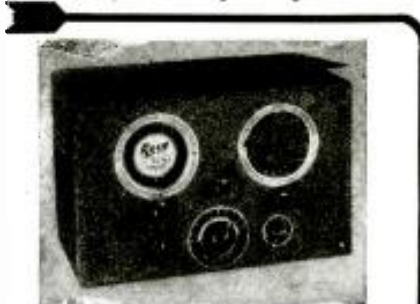

## ORIGINAL HAYNES R-S-R 5-Tube Receiver 2 1/2-555 Meter

This remarkable Regenerative-Super-Regenerative receiver has become too well known to require further description or praise by us. The many hundred R-S-R's we have sold are speaking for themselves. Ask your friends about it and look at their logs of foreign DX.

Complete R-S-R set; wired, tested, in hinged top crystalline cabinet with dynamic 5 tubes (2-6K7's, 1-76, 1-MG25Z5, 1-MG13) ready to plug in and operate.....\$24.65

Complete kit; unwired, including dynamic speaker, power supply, and wired switch coil assembly (less cabinet and tubes).....14.95

Hinged top crystalline cabinet.....2.50

Kit of 5 selected tubes.....3.60



**RADIO CONSTRUCTORS LABORATORIES**  
Dept. SW-8, 136 Liberty St. New York, N. Y.



## R-S-R PORTABLE 1-Tube Receiver 5-555 METERS

The smallest of the R-S-R family but delivering the same fine performance, this Regenerative-Super-Regenerative receiver, with self-

contained batteries, utilizes a new, unique circuit which provides unusual single tube performance. Foreign reception guaranteed. Full bandspread with separate tank condenser gives easy, precise tuning on either phone or CW. This is a portable job you will be proud to show your friends; another of our sensational direct-sale Summer specials.

- Complete kit of parts, including all coils from 15 to 555 meters; less cabinet, tube battery and 5-10 meter coils, unwired.....\$3.75
- Crystalized cabinet.....1.00
- 30 tube (1)......50
- Assembled, wired and tested.....1.35
- 5 or 10 meter coils, each......30

receiving station has in front of him a dial, similar to those on the ordinary dial telephones. By the operation of this dial he is able to start up or shut down a transmitter 350 feet away, increase or decrease its power as required, or change to any required wavelength. Each of these operations takes but a few seconds to complete, while a system of indicators keeps the operator informed of the conditions under which the transmitter is functioning. The whole system is duplicated to guard against possible breakdown.

Elaborate precautions have been taken to prevent the radio system being put out of commission by power failure. The whole system is supplied by a special power-plant generating alternating current. The dynamos for supplying the current are duplicated, so that even if one were to break down, the radio service can still "carry on" at full capacity.

In the possibility of grave emergency, under which both generating plants for the radio system might be put out of action, a complete emergency station, operated entirely from the ship's emergency lighting supply or from storage batteries, is available.

### ATTENTION! HAMS!

Next Issue of this Magazine will contain many valuable "Ham" Features!

## ...Class B Modulator \$2.79

Kit for 53, 79, 46, 59, 49, with Transformers LESS TUBES

Specify Tubes to be used

Write for full Information on

## The Little Giant! S. W. Receiver!

Summer specials on Ultra-High Frequency Parts Transceivers and Tubes.

**M. & H. Sporting Goods Co.**  
512 Market St., Phila.



## UNIVERSAL VELOCITY AND CARBON MICROPHONES

Universal's latest achievement

—Ideal for stage use—Not affected by temperature or humidity—Flat frequency response curve from 40 to 10,000 cps; Output 63 db; Low impedance or direct to grid types.

Compact 2 3/4 x 4 1/4 in. by 1 1/2 in. thick—Weight, less than 18 oz.—Head swings to any desired angle—Beautifully finished in black enamel and artistic chrome plate—ask for new catalog sheet describing models RL, RP, RH and CB—List \$22.50—Latest model music type sectional stand for above microphones—List \$10.00.

**UNIVERSAL MICROPHONE CO., Ltd.**  
424 Warren Lane Inglewood, Calif., U.S.A.

# RADIO INSTRUCTION

You Can Become a Fast, Capable RADIO OPERATOR at Home

## With the Famous CANDLER Scientific Sound System

That Trained Champions Jean Hudson and Ted McElroy.



Let us help you obtain your Amateur or Com'l license. Tell us what you need. Learn code RIGHT with the System that taught the Champions! Easy, Fascinating, Inexpensive.

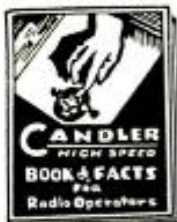

**FREE BOOK OF FACTS**  
Send for it. No obligation.

**CANDLER SYSTEM CO.**

Dept. 5-B ASHEVILLE, N. C.

MAC KEY @ \$7.95 finest speed key built; MAC OSC @ \$3.95 ac/dc oscillator. Tone control; MAC CORD \$1.00 navy spfn speed key cord; MAC MARINE receiver 550-850 meters, r u intd? Few deluxe MAC KEYS @ \$15.00 fm md. Write. T. R. McElroy, 23 Bayside St., Boston, Mass. If u hv May Key write me for xmy ipt & dsrb ifn.

WATCH FOR THE NEXT "HAM" NUMBER. THE SEPTEMBER ISSUE. OUT AUGUST 1

### Be a TELEVISION EXPERT

**LEARN TELEVISION with RADIO—NOW!**  
Great opportunity in exports in this amazing new industry. Recent developments in radio make television a certainty NOW. We teach you by air on the job method Radio and Television from learning to end in our marvelously equipped labs and studios. You actually operate thousands of dollars worth of expensive equipment. You get expert instruction and full guidance by radio-television specialists.

**Demand for Television Experts**  
Television now perfect and ready for the market ON THE NEXT big BUYING WAVE. Business leaders predict new system television will require thousands of relay and installing stations. Ultra-short waves will permit eighty thousand television stations in America alone.

**GET IN NOW!** Join the world's largest million dollar industry.

**6 MONTHS THOROUGH PRACTICAL TRAINING**  
Qualify yourself for the most important and profitable position in the radio-television industry. The radio-television expert is in demand everywhere. Earn big money. Write for details.

**FREE BOOK**

**S. Q. NOEL, Pres. First National Television, Inc.**  
Dept. B-8, Power & Light Bldg., Kansas City, Mo.  
Write for details. Send for FREE book. "The Res On the Air" tells about every detail of the radio-television industry.

Name \_\_\_\_\_  
Address \_\_\_\_\_

## Radio Amateur Course

(Continued from page 219)

sign will provide sufficient audio amplification. Coupling between the beat frequency oscillator (B.F.O.) and the second detector is accomplished through the suppressor of the detector, the same as was done in the original diagram in Fig. 1. This provides an excellent method of coupling the beat oscillator to the second detector. However, the power output of the B.F.O. must be greater with this system than if it were coupled to the grid circuit of the second detector or the second I.F. amplifier. Coupling to the I.F. amplifier or grid circuit of the detector allows a greater chance of running into difficulties than the method shown. For instance, coupling to a grid circuit we may have the tube, to which the oscillator is coupled, considerably overloaded due to the output of the oscillator driving the grid positive. In many commercial receivers coupling is accomplished merely by running a wire from the tuned circuit of the beat oscillator near a grid wire. Should the distance between the two or the couplings change appreciably, a considerable change in results would be noticed. If the coupling becomes too great the entire amplifier may "go dead," in so far as the incoming signal is concerned, because of the fact that it is already overloaded by the signal generated by the B.F.O. In reality there would be an optimum coupling for each value of signal going through the amplifier which we wish to heterodyne. The best that can be hoped for is a "happy medium" adjustment.

We suggest that the experimenter be very careful in using the above mentioned methods, and wherever possible avoid them.

The amplifier shown in Fig. 4 is equipped with automatic volume control, which is more or less essential for phone reception, but does not work out to advantage with code. In Fig. 5, we have shown how automatic volume control (A.V.C.) may be incorporated in a receiver of similar design. Here we have used a *duo-diode triode* as the second detector and first stage of audio amplification. In the second detector circuit, we rectify a portion of the incoming signal and feed it back to the grids of the I.F. amplifiers in the form of negative bias, which cuts down the gain of the receiver. In this manner, a strong signal will allow a large amount of negative bias to be applied to the grids thus cutting the gain of the receiver to a further degree than would a weaker signal. In this respect we obtain a fairly constant signal level. In this second detector circuit it is necessary to couple the oscillator to one of the diode leads. Here we must be very careful, because excessive coupling would, when the switch was in the A.V.C. position, reduce the gain of the receiver the same as would a strong signal or station. It is not so critical in the C.W. position, that is, when the A.V.C. switch is in the *off* position. But, at the same time, considerable cut and dry will be necessary in order to bring about an optimum in coupling. The diode second detector, of course, cuts down the gain of the receiver considerably. In the 57 we had quite a gain, while in the diode there is actually a loss. However, the diode provides quieter reception inasmuch as second detector hiss is entirely eliminated.

Why not purchase a SHORT WAVE CRAFT binder or a loose-leaf book and file these "Course" Lessons. Some day before you know if these lessons are going to prove most valuable to you.

## RADIO or MORSE CODE

INSTRUCTOGRAPH —THE EASY WAY TO PASS GOVERNMENT EXAMS

This Code Teacher is the most practical short cut to increase your speed and quality in Gov. exams. Instructograph sends you perfect code at any speed desired. Practice when convenient—It's always ready. Comes in two models—Senior or Junior Economy with complete Book of Instructions. You may buy or rent, at low cost. Just send postcard for complete details how to—



**INSTRUCTOGRAPH Company, Dept. SW-8**  
912 Lakeside Place, Chicago, Ill.  
Canadian Representatives  
Radio College of Canada, Ltd., 663 Bay St., Toronto

## TRI-STATE COLLEGE

**Radio Engineering** Degree in 2 Years  
Complete Radio Engineering course in 96 weeks. Bachelor of Science Degree. Radio (television, talking pictures and the vast

electronic field) offers unusual opportunities for trained radio engineers. Courses also in Civil, Electrical, Mechanical, Chemical, Aeronautical, Engineering; Business Administration and Accounting. Low tuition, low living costs. World famous for technical two-year courses. Those who lack high school may make up work. Students from all parts of the world. Located in picturesque hill and lake region of northern Indiana. Enter September, January, March, June. Write for catalog.

2586 COLLEGE AVE. ANGOLA, IND.



**Earn While Learning at Home!**  
TELEVISION, PHOTO ELECTRIC CELLS, PUBLIC ADDRESS  
Many R-T-I Trained Men make up to \$75 a week and more in full-time radio jobs—\$5-\$15 in spare time alone. More trained men needed. Learn at home by quick, easy, R-T-I WAY. Endorsed by 50 big concerns. Write for big Opportunity Book FREE.

**PHILCO CROSBLEY ZENITH GRUNOW and 46 other mfgs. endorse R-T-I**

RADIO AND TELEVISION INSTITUTE, Inc.  
2150 Lawrence Ave., Dept. 21-C, CHICAGO, ILL.

## QUICK WAY to make money in RADIO

Modern receivers are demanding men with modern training for service work. New training method and service equipment offer starts you earning almost at once. Up to \$3 an hour easy in a short time. Write today for FREE book of details.  
Radio Training Association of America  
Dept. 5-W.C.-68  
4525 Ravenswood Ave., Chicago

## RADIO ENGINEERING

RCA Institutes offers an intensive course of high standard embracing all phases of Radio. Practical training with modern equipment at New York and Chicago schools. Also specialized courses and Home Study Courses under "No obligation" plan. Catalog. Dept. SW-38.

**RCA INSTITUTES, Inc.**  
75 Varick St., New York. 1154 Merchandise Mart, Chicago  
Recognized Standard in Radio Instruction Since 1909

## RADIO ENGINEERING

broadcasting, aviation and police radio, servicing, marine radio telegraphy and telephony, Morse telegraphy and railway accounting taught thoroughly. Engineering course of nine months' duration equivalent to three years of college radio work. All expenses low. Catalog free. School established 1874.  
Dodge's Institute, Turner St., Valparaiso, Ind.

# Radio 100 Years Old!

(Continued from page 201)

gap left in the inducing coil! This brilliant scholar demonstrated that Maxwell's theoretical reasoning was correct and later more elaborate experiments conducted by Hertz tended to prove conclusively that the medium which serves to carry the vibrations of light and the medium which is vibrated by electro-magnetism is one and the same! Further, that each phenomenon travels with the same velocity; and not only this, but Hertz was able to demonstrate that electro-magnetic waves are reflected from conducting surfaces and also refracted by dielectric substances (analogous to the reflections of light from polished surfaces and its refraction through glass prisms). As Sewall further says—"Hertz was the first to understandingly transmit electric waves through ether, and he is the most important figure in the history of radio. From his discovery in 1886, that etheric vibrations or waves would result from the passing of sparks across an air-gap, began the real development of electric transmission of intelligence without conductors."

## Hertz's Demonstration of Wave Transmission

One of the classic experiments of Professor Hertz was carried out with a spark coil for the transmitter, while the receiver was simply a loop of copper wire with a small spark gap formed between two small metal balls. When this loop of wire, which formed a resonator, was placed in the proper position with respect to the radiator wires of the transmitter spark-gap and its coil, tiny sparks were seen to jump across the gap between the balls. By placing a sheet of metal in different positions behind the transmitter and receiver alternately, Hertz showed that the waves could be reflected. The waves used were short waves and probably of the order of one meter in length, judging from the dimensions of the wire loop with its ball spark gap, which he used as a resonator (receiver) and also the dimensions of his transmitter radiator system.

## Lodge Transmitted Radio Signals in 1890

About 1890, Sir Oliver Lodge, the famous English scientist, was making many experiments in London with apparatus of his own design, and with which he was able to demonstrate the transmission of signals over short distances. Of course, short waves were also used in this case, as we now know, for Lodge did not use an aerial or ground connection, and thus there were no long wires to raise the wavelength above that of possibly a few meters.

## 1890 to 1900—Ten "Eventful Years" in Radio

The ten years between 1890 and 1900 were very fruitful ones, so far as radio inventions were concerned, and a whole group of radio, or as they were then called, "wireless" inventors, come in upon the scene during this eventful ten year period—some of the most famous names in radio history.

Aside from Lodge, the most important figure to appear in the "theatre of radio invention" in this remarkable ten year period was Guglielmo Marconi. Marconi was born in Bologna, Italy in 1874, his father, an Italian nobleman, and his mother of Irish nationality. Guglielmo Marconi studied at Leghorn University under Professor Rosa and later he studied under Professor Righi at the University of Bologna.

After a study of a number of important works, describing the early days of radio history, including the famous classic—"Signalling Through Space Without Wires," by Lodge, and "The Principles of Electric-Wave Telegraphy," by Dr. J. A. Fleming and others, a very important historical point of supreme interest now comes to light, to wit: after studying these experiments of Lodge in 1890 and the years shortly thereafter, and after reading what

### 3-Tube Portable Transceiver (2 1/2 TO 10 METERS)



(Built-in Loud Speaker)  
A compact powerful 2 1/2, 5 and 10 meter portable transceiver designed for loud speaker operation, is now available in the Ultra 3 B. This remarkable unit will be found capable of maintaining positive contact when communication is once established. Class A 100% modulation is employed. This has been made possible by the new 2 Volt tubes; 1F1 Class A modulator—1B1 high gain speech amplifier. These together with a 19 tube, Oscillator-Super regenerative detector result in an ideal transceiver. When used as a receiver loud speaker volume is assured. In ideal localities a workable range up to 200 miles may be expected.

Complete kit of parts including all coils, low battery, tubes, speaker, microphone and cabinet, unwired.....	\$9.95
Wired and tested.....	\$2.50
Sylvania 19 and 1F4 matched set of 3 metal tubes.....	2.50
Cabinet with built-in speaker and battery compartment.....	2.25
Cabinet less built-in speaker with battery compartment.....	1.95
Cabinet less built-in speaker, less battery compartment.....	1.10
Hand microphone.....	1.25
Hand microphone.....	1.25

### Ultra 4A-4-Tube A.C. Operated Transceiver (2 1/2 to 10 Meters)

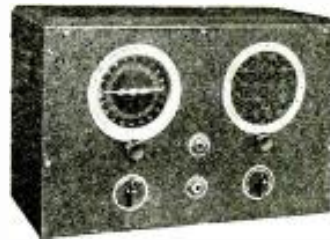

In the design of the Ultra 4A, A.C. operated transceiver, every tradition of radio value has been incorporated. Built-in dynamic speaker.

self contained power supply. Class A 100% modulation are only a few of the outstanding features of this "Ultra High Frequency" product. The new all metal tubes are used as follows: 6F6, Class A modulator—Power amplifier, 6J7, high gain speech amplifier—1st A.F. amplifier, 5Z1, rectifier, 6A8, Oscillator-detector. The Ultra 4A is completely filtered at both R.F. and A.F. Levels. Automatic phone jack silences speaker. Tuning range 2 1/2 to 10 meters with 5 watts output.

Complete kit of parts including all coils, low cabinet, tubes, microphone, unwired.....	\$15.95
Wired and tested.....	\$3.00
Black wrinkle finished cabinet.....	2.50
Sylvania 6A8, 6J7, 6F6, 5Z1 matched set of 4 tubes.....	3.40
Hand microphone.....	1.95

Pictorial diagram furnished with kit.

### (2 1/2 To 550 Meters) All-Wave Amateur 5-Tube Communications Receiver



A new radio amateur communications receiver featuring 5 tube bandspread plus regeneration and super regeneration is now available for the use of the disseminating amateur. 2 1/2 to 550 meters linear in efficiency is accomplished by the use of super regeneration up to 15 meters and straight regeneration with 5 band stretching to 550 meters. The new all metal tubes are used as follows: 6K7—R.F. stage, 6K7—Regenerative detector, 76—super regenerative detector, 25A6—Power output stage, 25Z6—rectifier. Built-in dynamic speaker, self-contained A.C.-110, power supply, large airplane bandspread dial, automatic phone jack.

Complete kit of parts less tubes and cabinet, unwired.....	\$13.95
Wired and tested, extra.....	\$3.00
Sylvania kit of 5 tubes.....	4.50
Black wrinkle finished cabinet.....	2.50
Set complete with 5 tubes and cabinet, wired, ready to operate.....	23.10

Pictorial diagram furnished with kit

### Ultra 1 and 2 Tube Battery Transceivers



For the beginner in the field of ultra high frequencies we unhesitatingly recommend these extremely efficient 1 and 2 tube transceivers. 1 can be used as a 2 1/2, 5 and 10 meter receiver as well as transmitter when calling friends from afar. The one (1) tube unit uses a 19 (21A) tube. The 2 tube unit uses one 1B, plus the (new) 1F4, Class A modulator. Longer battery life is had with this combination. Greatest possible range of any all transceivers on the market. Range of 1 tube unit may be as high as 30 miles, and up to 100 miles with the 2 tube depending on locality. Batteries required are 2 1/2 V. dry cells and 90 to 135 V. battery.

Complete kit of parts including all coils, low tubes, cabinet, microphone and batteries, unwired.....	\$6.95	Complete kit of parts including all coils, low tubes, cabinet, microphone and batteries, unwired.....	\$4.95
Wired and tested.....	\$2.00	Wired and tested.....	\$1.50
Sylvania 19 and 1F4 matched tubes (2).....	1.45	Sylvania 19 tube.....	.58
Cabinet less battery compartment.....	1.10	Cabinet less battery compartment.....	1.10
Cabinet with battery compartment.....	1.95	Cabinet with battery compartment.....	1.95
Hand microphone.....	1.95	Hand microphone.....	1.95

WRITE IN FOR FREE DESCRIPTIVE ULTRA HIGH FREQUENCY LITERATURE  
**ULTRA HIGH FREQUENCY PRODUCTS COMPANY**  
 140 LIBERTY STREET  
 NEW YORK, N. Y.

some of the famous inventors at that time had to say themselves, a remarkable fact presents itself—it almost happened that Lodge instead of Marconi might have been heralded today as the inventor of practical radio transmission!

## Lodge Apparatus Lacked Aerials

As Lodge once said after Marconi had made his first demonstrations in England over a distance of a dozen miles or more, and utilizing an elevated aerial wire as well as ground connections—"If we had only thought to use the elevated aerial wire on our apparatus!" Meaning that if he had used an aerial to give him more powerful transmission, he (Lodge), could have demonstrated similar effects of transmitting signals over a considerable distance, the same as Marconi did six years later. Lodge and his co-workers had built sensitive apparatus for detecting the presence of the waves and they were quite familiar, of course, with the effects of cohesion of minute metal particles in the presence of a spark or a wave set up by a spark. But it remained for Marconi to add the second important step to his train of inventions, and to improve the coherer (given its original name by Lodge) by enclosing the metal filings in a glass tube, from which the air was evacuated by a vacuum pump. This prevented the oxidation of the metal filings and improved the sensitivity of the device enormously, and also its reliability.

It is interesting at this point, as Sewall relates, that at the time Hertz announced his first etheric short-wave transmission,

## GET ON THE LIST FOR THESE CATALOGS



Here are the four big catalogs sent to every Burstein-Applebee customer this year. Each catalog is brim full of latest information and lowest wholesale prices on Radio, Electrical and Refrigeration Equipment. Write today—get on the list.

**BURSTEIN-APPLEBEE CO.**  
 1012-14 McGee St., Kansas City, Mo.

## 10-METERS

The band that is offering new thrills  
 Build a 10-Meter "Rig" with  
 Nationally Advertised

## RADIO PARTS

Regularly stocked by us for the  
 Amateur and the Experimenter  
 Write for our free catalog

## CAMERADIO

601-3 GRANT ST., PITTSBURGH, PA. 30 TWELFTH ST. WHEELING, W.VA.  
 Established 1919

Please mention SHORT WAVE CRAFT when writing advertisers

# Everything in RADIO

1936

Send for FREE 136 page Radio Catalog packed with 10,000 parts, dozens of kits, sets, tools, books, etc. Latest Televe, metal tube, 6 volt and battery sets; new Amateur gear; low-cost Sound Equipment; dependable service instruments. Special Amateur-Experimenters, Service and P. A. sections. Get your copy now!

## BUILD YOUR OWN

Write to us for FREE parts list for building any transmitter or receiver described in any radio magazine or handbook. Use ALLIED approved parts and be assured of best results. For faster service, greater values and lower prices—order from the ALLIED Catalog.

# ALLIED RADIO

ALLIED RADIO CORP. Dept. E.  
833 W. Jackson Blvd., Chicago, Ill.  
 Send me your FREE Radio Catalog

Send me Parts List for

Name.....

Address.....

## Short Wave League Letter-heads

Designed for Members

It is invaluable when it becomes necessary to deal with the radio industry, mail order houses, radio manufacturers. It can be used in many ways and gives you a professional standing. No member of the LEAGUE can afford to be without this letterhead. This can only be used by members of the LEAGUE. No one else can purchase it. Take advantage of this opportunity to handle your LEAGUE correspondence in a business-like manner.



This is the official letterhead

See Page 252 for order blank.

SHORT WAVE LEAGUE

99-101 Hudson St., New York, N. Y.

Manufacturers of

VITREOUS TRANSMITTING GRID LEAKS  
VOLUME CONTROLS · POWER RHEOSTATS

Write for Complete Free Catalog

**ELECTRAD, Inc.**

175 Varick Street, New York

## We Make to Your Specifications

Metal Cabinets, Chassis, Shield Cans to fit Chassis, Panels—Aluminum or steel.

Send us your drawing for estimate.

**KORROL MFG. CO. Inc., Dept. S-8**  
232 Greenwich St., New York City

QUALITY PARTS FOR HAMS SERVICEMEN RADIO INDUSTRY

Complete facilities to meet every requirement in drilling and engraving of panels, and on all insulating materials and metals. Write today for complete descriptive catalog on parts of standard manufacture. Send for stamps or coins to cover cost of handling and mailing.

INSULINE CORP. OF AMERICA  
25 PARK PLACE NEW YORK, N. Y.

## American Microphone Co., Inc.

CRYSTAL, ELECTROSTATIC CARBON, AND CONDENSER

Microphones, Stands, and Accessories

New catalogue available upon request.  
1915 South Western Ave., Los Angeles, Calif.

Lodge was also conducting experiments along similar lines, and Hertz afterwards said that in time Lodge would undoubtedly have reached the same results as himself!

Branly (1890) of France is generally given credit for the discovery and careful research on the coherency among metal filings, whenever an electric spark at a distance was caused to be discharged in the neighborhood. Prof. Calzecchi Onesti\* in Italy (1884) was probably one of the first to observe a similar effect or rather the effect on the conductivity of metallic powders under the action of various voltages.

Many investigators noted the effect of spark or electric discharges on metal or carbon particles, one of the very first of record being Munk of Rosenschoeld, who in 1835 (100 years ago) described the permanent increase in the electric conductivity of a mixture of tin filings, carbon, and other conductors, resulting from the passage through it of the discharge of a Leyden jar (see Fleming, page 356). Also Varley (1856) noted the rapid fall in resistance of loose metallic powder whenever a lightning flash occurred. In 1878, Hughes, while experimenting on microphones, noted that a glass tube filled with filings of zinc and silver, connected in series with a telephone receiver and a battery cell, was sensitive to electric sparks at a distance, as evidenced by its sudden change in conductivity.

### Basis of All "Tuned" Circuits

As one of the accompanying pictures shows the basis of tuned radio circuits was laid down in 1890 by Lodge, when he described before the British Institution of Electrical Engineers, in London, some of his experiments in which he was able to show the coherer effect and also—highly important to radio history—the transmission and reception of short waves (probably a meter or so in length), by means of sharply tuned circuits.

The "recently invented" long lines oscillator is, broadly speaking, nothing but a re-invention of Lodge's syntonie circuits, demonstrated and described by him forty-six years ago!

Lodge's apparatus involved two polished metal balls resting close together in a vertical plane so that whenever a spark passed between them, they cohered or tended to stick together, and caused the electric bell circuit connected with them to become conducting; the bell signalled this fact.

Those interested in the early days of radio history will do well to refer to Lodge's scientific papers and books, now out of print but available at the principal public libraries, as many interesting and basic experiments were illustrated and described by Lodge in these papers, especially with regard to tuned circuits and tuned radiating aeriels and antenna systems.

Radio men today probably think that they have made quite a departure in transmitting and receiving circuits because on short waves they generally do not use a ground, but employ instead a balanced radiator system, comprising a couple of rods or an aerial such as the "doublet" type. Too bad to spoil your dream, S-W Fans, but Lodge was there first, and the diagrams and descriptions of his apparatus, which experiments were carried on in those famous ten years between 1890 and 1900, show all sorts of doublets and tuned circuits, very much like those now in use. Lodge also understood and demonstrated plenty of examples of standing waves of various fractional wavelengths.

With the Lodge coherer shown in the diagram, the bell continues ringing, of course, until the polished metal knobs are gently tapped asunder, except where the bell stands on the same table as the knobs; when it is first struck, it taps them back instantly and automatically. Thus every discharge of the "sending" or transmitting Leyden jar is signalled by a single stroke of the bell.

Lodge Had "Sharply Tuned" Circuits

Note that Lodge tuned his syntonie

\* Il Nuovo Cimento, 1884, Vol. 16, p. 58, also 1885, vol. 17, p. 35, and Journal de Physique, 1886, vol. 5, p. 573.

(tuned) transmitting and receiving Leyden jar circuits by moving a metal slider, S, along the metal rods; he further points out in one of his descriptions of this apparatus that the transmitting and receiving circuits must be accurately tuned together, if there is to be any response. Lodge also stated that a very little error in tuning, such as caused by altering the position of the slider, S, will make them quite unresponsive, unless the distance between them is reduced.

In 1894 Lodge gave his famous lecture, in England, in which he reviewed the work already done with Hertz's oscillator, with Branly's coherer, and also with the apparatus devised by himself and Dr. Muirhead. Some of the apparatus devised by Lodge and Muirhead is very ingenious and worthy of study by everyone interested in the history of the art.

### Nikola Tesla

Nikola Tesla was one of the earliest radio investigators and undoubtedly those connected with the development of radio circuits, especially tuned oscillatory circuits, in the period between 1890 and 1900, were influenced in many cases by the pub-

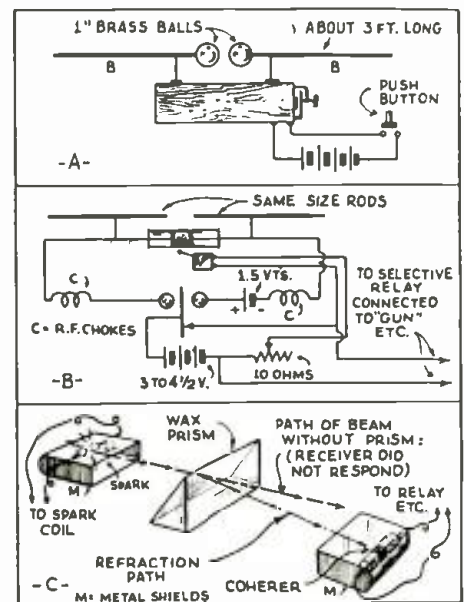

Top—Early S-W Transmitter, using spark-coil. Center—Receiver, using coherer and decoherer. Below—How bending of waves was demonstrated at an early date.

lished diagrams of the famous Tesla coil oscillator circuit, and also Dr. Tesla's patents on tuned circuits. The Tesla coil and circuit description for the production of high-frequency operations was described in his patent application filed April 5, 1891. Among other famous Tesla patents, is one describing a system of controlling the movements and operations of a vessel or other object at a distance, in a patent application dated July 1st, 1898.

As early as June 20, 1896, Tesla took out a patent describing his famous system of concatenated "tuned" circuits. Other patents were taken out by Tesla, covering the methods of storing the energy transmitted, and strengthening feeble signals, etc., in a series of patents granted in 1901. In 1893 Tesla delivered his famous lectures before the Franklin Institute in Philadelphia and the National Electric Light Association in St. Louis, in which he advanced a plan of wireless transmission, not only for the transmission of telegraphic signals—but also for the transmission of power!

Reference to Sewall's "Wireless Telegraphy" discloses an interesting description and also diagrams of Tesla's radio power transmission system.

Lecher is given credit by many radio historians for the invention of oscillatory circuits, similar to those used today for short-wave transmitters, etc., and on which stationary electric waves are produced or

set up. Fleming points out, however, that practically all the circuits ascribed to Lecher by certain writers were originally used by Lodge and also by Hertz.

In 1895, Count Popoff of Russia appears upon the scene and, judging from the references to his work, it would seem that he never demonstrated any transmission of signals with his apparatus, which involved a coherer. Also any ideas he entertained of transmitting telegraph signals, for instance, to a distance, were mostly in his mind, and his practical results were principally along the line of a sensitive detector (including a collecting wire or aerial) of atmospheric electrical discharges such as lightning.

In 1896, Marconi came to England and succeeded in transmitting signals across a space of 100 yards (300 feet) at the British Post Office in London. Shortly thereafter he made another demonstration over a distance of two miles at Salisbury Plain. In May, 1897, Marconi transmitted signals successfully over a distance of nine miles over water in England and during the next few years the signalling distance negotiated by the Marconi system increased rapidly, until it culminated in the great surprise for electrical men on both sides of the Atlantic, when he finally linked Europe and America with the historic signal of three dots, representing the letter "S," on December 12, 1901.

**Marconi's First Tests Employed "Short Waves"**

It is interesting to note that *short waves* were first used by Marconi in his experiments in Italy in the 1890's and one of the first elevated wires or aeriels he used was two meters long, and thus on the quarter-wave theory, the wave-length was probably about 8 meters. Marconi found that he could transmit signals and receive them, utilizing a coherer, etc., over a short distance of a few rods with the wire elevated *two meters*, a metal plate or cap being secured at the upper end of the wire where it was affixed to the top of the pole. He then bethought himself to try a higher wire and gradually he increased the height, until it was 8 meters or more.

Three basic and very far-reaching improvements were made by Marconi and these were as follows: *first*, he was the earliest inventor of record to use an *elevated wire or aerial*, and also a ground connection, at both the transmitter and receiver. Popoff, (1895) in Russia, had used an elevated wire—but only at the receiver (as a collector of atmospheric electricity.) He could pick up distant lightning and other atmospheric discharge effects. *Secondly*, Marconi vastly improved the coherer, as aforementioned, carefully determining by many experiments the best mixture of nickel, iron and other filings and placing them in an exhausted glass tube. It is also interesting to note that at this point it was Marconi who is given credit for the development of the *receiving apparatus*, relay, coherer, etc., which could be accurately adjusted so that when the key was depressed at the transmitter and a train of sparks were liberated in the spark gap, that a single "dash" signal would be recorded at the receiver and not a "series of jerky impulses."

*Third*, it was Marconi, as Fleming points out, who toward the close of the famous "ten-year period" between 1890 and 1900, who deduced the fact that the coherer or detector, when placed simply in series with the antenna and ground, was *not* working at its highest efficiency, as the voltage distribution at the base of the antenna was at its weakest value. The invention of the "jigger" or aerial coupling transformer was the result and this helped to increase tremendously the sensitivity of the receiver and the distance over which the apparatus would pick up signals. Not only were hundreds of different "jiggers" experimented with, but it was found by Marconi that the number of turns of wire or the inductance of the primary of the coupling transformer had to be suited to the particular wave-length to be received, and further, that when the circuits were, so to speak, considerably "out of tune," the response of

**Announcing SARGENT MODEL 11 UNIVERSAL—9.5 to 20,000 Meters**



**Model 11** has a world-wide range on short waves, and the operator who understands the handling of regeneration can also pick up many short wave broadcast stations that are lost in the noise on larger sets.

**EMERGENCY WAVE COVERAGE FOR AMATEURS.** The owner of a well equipped amateur station finds himself upon ability to establish emergency contacts. This includes the occasional necessity for listening in on 600 meters, on the airplane beacon waves and on the navy waves up to 3,000 meters. Amateurs are recognizing the need of a COMBINATION RECEIVER to go with that big super-het. Model 11 fills the bill, quiet, extremely sensitive, selective, flexible, easy to operate—a turn of the switch takes you from the 10 meter band up to 20,000 meters where NSS, GBR and others may be heard. C.W. operators especially are coming to realize the benefits offered by a tuned r.f. receiver which cannot be duplicated by any other kind.

**TIME SIGNALS.** Jewellers, yacht owners and others interested in time signal reception will find Model 11 exactly suited to their needs. It covers every wavelength on which time signals are sent.

**WEATHER REPORTS.** Sent out every hour of the day from airplane beacons, commercial stations, broadcasters and other services. Amateur meteorologists will find Model 11 a friend in need.

**SHIP TELEGRAPH.** Highest efficiency on 600 meters and on 2,200. Any ship operator will be proud to own a Model 11 for his own personal receiver.

**IMMEDIATE DELIVERY**  
We specialize in receivers for long wave coverage and for D.C. and battery operation.

**E. M. SARGENT CO.**  
212 9th St., Oakland, Calif.

**RADIO OPS!** Here's the receiver you've been waiting to hear about. Continuous tuning, without a break, from 9.5 to 20,000 meters. Dial calibrated all the way. Antenna trimmer, band spreader on all waves, break-in switch, phone jack—everything a real operator's receiver should have, and housed in our new attractive all-metal tray-type cabinet. A.C. models use 5 tubes, D.C. and battery models, 4. One stage r.f., regenerative detector, 2 audio. Tuned r.f. circuit. Built to highest standards of engineering design. Full efficiency at short waves, extension of tuning range introduces no additional losses, couldn't be better if designed for short waves only. Available in 3 tuning ranges.

Net prices on A.C. models follow:  
Model 11-0A, UNIVERSAL TUNING RANGE, 9.5 to 20,000 meters.....\$75.00  
Model 11-MA, MARINE TUNING RANGE, 9.5 to 3,750 meters.....\$54.00  
Model 11-AA, AMATEUR TUNING RANGE, 9.5 to 550 meters.....\$46.00  
Prices include power supply, speaker, I.C.A. tubes. Available for D.C. and battery operation, also A.C./D.C. with separate power pack. Write for details. IMMEDIATE DELIVERY.

**Model 10-5-Tube Receiver.** This popular receiver continues unchanged in our line. One tuning range only—9.5 to 550 meters—longer waves now covered by Model 11. Net price, Model 10 for A.C. operation, \$37.50 with power supply, tubes and speaker. Available also for D.C. and battery. Write for details.

the coherer was very weak—or else it was not effective at all!

One of the diagrams, which will undoubtedly be of interest to all present-day radio fans and hams, shows the Marconi apparatus as set up in 1896 for transmission and reception.

In this particular set-up, kites or balloons covered with tinfoil were used to hold the aeriels elevated above the ground but, of course, poles were generally employed. Another diagram shows the details of one of Marconi's jiggers and the secondary winding was frequently wound in sections of conical form, as shown.

Another very interesting point of interest to short-wave fans at this juncture, is that in some of his experiments Marconi placed the spark discharge balls in the focal line of a cylindrical parabolic mirror, and the receiver likewise in the focus of another similar mirror, using, for the purpose of collecting the *short-wave* energy, two metal straps or rods attached to the extremities of the coherer tube. The wave-length here, of course, was probably a fraction of a meter and the system is identical with that used today, roughly forty years later, except for the fact that we now use a vacuum tube oscillator instead of a spark gap, and an induction coil to excite it; also a vacuum tube in the focus of the receiving reflectors, instead of the little coherer tube with its attached aerial rods or collectors. It is interesting also to note that in the period around 1905 or 1906, that a *short-wave* system of radio transmission and reception was demonstrated on the American vaudeville stage by an Army captain, the coherer being used at the receiver, with a step-by-step selective relay, so that he could fire a small cannon, cause a flag to rise on a pole and do a number of other stunts. A one-inch spark coil was mounted on a short pole, fitted with a battery box, a flexible cable, and a push-button, so that when the usher walked along the theatre aisle, various persons in the audience could have the satisfaction of pushing the button and causing certain things to happen at the receiving apparatus on the stage. Many American, as well as European and other radio experimenters, at about this time experimented with a similar apparatus and it is interesting today when *short waves* are considered quite new, that all of these early demonstration apparatus were used with brass or other metal rods, about a meter in length, so that the wavelength employed was in the realm of what we now call short waves

**Be Considerate of the Older Folks!**



Of course, you want to hear Australia and other foreign stations, but you may not be able to get them until late at night or early in the morning. You can do both, if you use

The favorite set of "Hams"  
The phones are built with very heavy bar magnets which greatly increase their efficiency.

**CANNONBALL HEADSETS**  
Write for illustrated circular S-8  
**C. F. CANNON COMPANY**  
SPRINGWATER, N.Y.

Write to "Headquarters" and Get a Better Deal

**"CHI-RAD"**  
Headquarters for "Hams" for 15 years

The latest in receivers and transmitters —available on easy terms.

**Liberal Trades Arranged**  
Complete stock of parts and accessories at standard prices.

**CHICAGO RADIO APPARATUS COMPANY, Inc.**—W9PST  
415 S. Dearborn St. Chicago, Ill.

Mail us your order for the world's most reliable and accurate Balancing or Grid Condenser

**XL VARIO DENSER** in 4 ranges  
Mod. N, Cap. 1.2 to 20 MMF  
Mod. G1, Cap. 20 to 100 MMF  
Mod. G5, Cap. 100 to 500 MMF  
Mod. G10, Cap. 500 to 1000 MMF  
and the **XL PUSH POST** (best spring type Binding Post)



Mod. N \$1.00 ea.  
Mod. G \$1.50 ea.

Non-Corroding—Navy Type—Hak. Top 24 ea.  
Type B1 (Aluminum Base, Baseplate Insulated Top) 15c.  
Type M (All Aluminum Body) at 10c each.  
For quick connections and positive contact at all times.

**X. L. RADIO LABORATORIES**  
Dept. S.W. 8, 1224 Belmont Ave., Chicago, Ill., U.S.A.

Do You Own the 6 Best Short Wave Radio Books? See Page 256.

Please mention SHORT WAVE CRAFT when writing advertisers

## BUD IMPROVED MIDGET CONDENSERS

Note These Improved Features!



1. New Positive Wiping Contact on rotor shaft with adjusting screw, eliminates mechanical noise on high frequencies.
2. Close Fitting Bearings hold rotor calibration and smoothness of operation.
3. Insulated with ISOLANTITE. Soldered brass plate assemblies, and heavy aluminum end plates make a precision built, ruggedly constructed condenser.
4. Shaft extends 5/16" beyond rear bearing for gauging several units with flexible couplings.

Dual units and multiple space units in various capacities illustrated and described in our new catalog. Free upon request!

40% DISCOUNT TO AMATEURS

**BUD RADIO, INC.** 1937 E. 55th St. Cleveland, Ohio

Scout the Air Waves with H. G. Cisin's Amazing New 1936

### MIDGET METAL TUBE ALL-WAVE FOUR

4-Tube Kit  
Complete Kit with all coils, high-quality Find-All parts, and including drilled chassis and dynamic speaker less tubes, unwired. **\$9.95**

Set of four matched metal tubes—\$4. Also available wired and laboratory-tested, ready to use.

**ALLIED ENGINEERING INSTITUTE**  
98 Park Place, Dept. S-27, New York, N. Y.

### Short Wave League Members



IDENTIFY THEMSELVES WITH THE ORGANIZATION

In order that fellow members of the LEAGUE may be able to recognize each other when they meet, we have designed this button, which is sold only to members and which will give you a professional appearance. If you are a member of the LEAGUE, you cannot afford to be without this insignia of your membership. It is sold only to those belonging to the LEAGUE and when you see it on another, you can be certain that he is a member. See page 252.

- Lapel Button, made in bronze, gold filled, not plated, prepaid..... **35c**
- Lapel Button, like one described above, but in solid gold, prepaid..... **\$2.00**

### A REAL POWER PACK

at an unusually Low PRICE  
Only 100 Model X left  
325 Volts PURE DC at 50 Milli-ampere and 2 1/2 Volts AC CT 5 Amps. Completely wired and tested. Built on heavy steel chassis, finished in brown crackle. A rare bargain. Uses type 80 tube. Hurry, before they are all sold. **SPECIAL PRICE, only \$3.48**

General Engineering Corp., Dept. S-8, Charlotte, Michigan

## BUILD YOUR OWN ELECTRIC OUTBOARD MOTOR

From old auto generator. We show you how. Make money building for others. Variable Speed. Light weight and silent. Operates from 8 to 12 hours on ordinary storage battery. Blue prints complete simplified plans and catalog.

**LEJAY MFG., 1517 W. Lake, Minneapolis, Minn.**

### GENERAL CEMENT

**CRYSTALLIZING LACQUER**  
This crystal lacquer is especially adapted to provide a professional and finished appearance to all radio apparatus, such as: radio panels, chassis, test panels, analyzers, etc. Easily applied, is fast drying, air drying, and requires no baking. It can be used on all surfaces.

List Prices—2 oz. black \$2.00—2 oz. red, green, blue, brown, yellow 15c. Pint of black \$2.00. Pint of colors \$2.25.

See your radio hobbyist—if he cannot supply you, write us. Send for free circular of other radio needs.

**GENERAL CEMENT MFG. CO. Rockford, Illinois**

or approximately 4 meters in length (considering that each rod was about one meter long, representing one-half of a doublet or Hertzian radiator) and it was therefore 1/4 wavelength long. In some of the experiments, the rods were much shorter or only six inches long, when the wavelength was four times this or twenty-four inches, or roughly 1/2 meter in length.

In 1908, the editor, Hugo Gernsback, sold on the American market coherer type receivers and spark-coil transmitters, which operated on short waves of about this length. But we didn't think anything about short waves in those days, as such, the main thing being whether the apparatus would "work"—and magical indeed were the results, especially to laymen.

### Slaby, of Germany, an Early "Wireless" Inventor

One of the most interesting "sidelights" in radio history was that another man, who may have been heralded as the inventor of practical radio, was Professor Slaby, an engineering professor in the technical high school at Charlottenburg, Germany, and when the news of Marconi's successful demonstration in England in 1897 came to his attention, Professor Slaby at once hurried to England, as Fleming recites, to discover how Marconi had "solved a problem" that had hitherto baffled him (Slaby). Slaby saw Marconi's experiments in transmitting radio signals across the Bristol Channel, and he also assisted in some of these experiments.

Most interesting today is to read what Professor Slaby wrote in a magazine article on the "new telegraphy," in the Century magazine of April, 1898: "In January 1897 when the news of Marconi's first successes ran through the newspapers. I myself (Slaby) was earnestly occupied with similar problems. I had not been able to telegraph more than 100 meters through the air. It was at once clear to me that Marconi must have added something else—something new—to what was already known. . .

"In certain professional journals an attempt has been made to deny novelty to the method of Marconi. It was urged that the production of Hertz rays and radiation through space, the construction of his electrical eye—all this was known before. Though all this had been known to me also (Slaby) and yet I never was able to exceed 100 meters (328 feet).

"In the first place, Marconi has worked out a clever arrangement for the apparatus, which by the use of the simplest means, insures technical results. Then he has shown that such telegraphy was to be made possible only through, on the one hand, a ground connection between this apparatus, and, on the other, the use of long extended upright wires. By this simple but extraordinary effective method he (Marconi) raised the power of radiation in the electric forces a hundred fold."

So much for these few interesting "highlights" on the early history of practical radio transmission and reception of intelligence, and perhaps at a later date, if enough requests are received from readers, we may go into more detail on some of the later inventions, such as the inventions of the vacuum tube detector by Fleming, generally known as the "Fleming valve" (including the "Edison effect" noted by Thomas A. Edison in 1883) and the sensitivity of which was enormously increased by the addition of the third electrode or grid by Dr. Lee de Forest; and a host of other inventions, including the regenerative circuit, the superheterodyne circuit and the great horde of electrolytic, crystal and other detectors which flooded the stage of invention in the years between 1900 to 1917, which would form a most interesting article and space for which is not available here.

### CORRECTION

● IN our January number, page 518, we published an article entitled, "New S-W Sets at the German Radio Show." One of the sets, including a photo of the "Fly Wheel" tuning dial arrangement, was labelled, "Newest Telefunken S-W Receiver." We are glad to announce that this was not a Telefunken receiver but a "Blaupunkt," Idealwerke A. G. fuer Drahtlose Telephonie.

# DATAPRINTS

Just the CONSTRUCTION

Information

You Need

To Build

Electrical

Apparatus

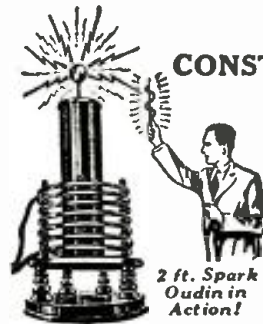

2 ft. Spark Oudin in Action!

### TESLA OR OUDIN COILS

Dataprint containing data for constructing this 3 ft. spark Oudin-Tesla coil. Requires 1 K.W. 20,000 volt transformer as "exciter". **\$ .75** see list below. Includes condenser data. . .

- 8 inch spark, data for building, including condenser data; requires 1/2 K. W. 15,000 volt transformer; see list below..... **0.50**
- Violet type, high frequency coil data; 110 volt A.C. or D.C. type; 1" spark; used for "violet ray" treatments and "Experiments"..... **0.50**
- How to operate Oudin coil from a vacuum tube oscillator..... **0.50**
- 3 inch spark Tesla coil; operates on Ford ignition coil..... **0.50**
- 3 inch spark Oudin coil; 110 volt A.C. "Kick-Coll" (Vibrator type.)..... **0.50**
- 20 Tricks with Tesla and Oudin Coils..... **0.50**

### TRANSFORMER DATA

- 1 k.w. 20,000-volt transformer data, 110-volt, 60-cycle primary. Suitable for operating 3 ft. Oudin coil..... **0.50**
- 1/2 k.w. 15,000-volt transformer data, 110-volt, 60-cycle primary. Suitable for operating 8-inch Oudin coil..... **0.50**
- Electric Welding Transf. (2 K.W. 110 Vt. Prim. 18 Vt. Sec. (Other Ser. Vt. data given.)..... **0.50**
- Induction Coils—1 to 12 inch spark data..... **0.50**
- ARTIFICIAL FEVER Apparatus..... **0.75**

(Low, Medium & High Power Data Given)

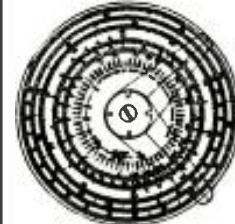

### SLIDE RULE

MIDGET

Metal 4" Dia. Price \$2.00 Net.

With case and instructions

This rule solves any problem in multiplication, division, addition, subtraction, and proportion; it also gives roots and powers of numbers, sines, cosines, tangents and cotangents of all angles; also logs, numbers. Adds and subtracts fractions. Approved by colleges.

8" Dia. 25" Scale "Special" Rule, \$5.00 Net.

**TELEGRAPHONE** — Records Voice or "Code" signals on steel wire by magnetic action. Code can be recorded "fast" and translated "slow." Construction data (special)..... **\$0.80**

### MAGNET COIL DATA

- Powerful battery electro-magnet; lifts 40 lbs..... **\$0.50**
- 110 Volt D.C. magnet to lift 25 lbs..... **0.50**
- 110 Volt D.C. 300 lb. Lift electromagnet..... **0.50**
- 110 Volt D.C. solenoid; lifts 3 lb. through 1 in. **0.50**
- 110 Volt D.C. solenoid; lifts 6 lb. through 1 in. **0.50**
- 12 Volt D.C. solenoid; lifts 2 lb. through 1 in. **0.50**
- A. C. Solenoid, powerful, 110-volt, 60-cycle..... **0.50**
- MOTOR—1/16 H.P., 110 volt A.C., 60 cycle (suitable for driving 12" fan, etc.)—Data..... **0.50**

### MISCELLANEOUS DATAPRINTS

50c each Prepaid

- Radio Control for Model Boats..... Motor
- Electric Refrigerator Data..... Induction Balance
- Treasure or Ore Locator..... Telautograph
- Water Turbines..... Einthoven String Galvanometer
- Water Wheels..... Electric Fan Motor
- Motor (Brush) (20)..... Watch Demagnetizer
- Telephone Hook-ups 120..... Electric Furnace Drain
- 100 Mechanical Movements..... Regulator
- Polarized Relay, Ultra-sensitive..... Building a Simple Telephone
- Shocking coil..... Ignition Coil Data
- Ring 4 bells on 1 circuit..... Battery Motor (small)
- 20 Simple Bell Hook-ups..... Wheatstone Bridge
- Public Address System..... Rotary Converter
- Electric Chime Ringer.....
- fits any clock.....

20 "Electrical Tricks" for LODGES and PARTIES..... **\$0.50**

How to Fry Eggs on Cakes of Ice Electrically..... **\$0.50**  
"Rewinding" Small Motor Armatures..... **0.50**

"ENGINEERING SERVICE BY MAIL"  
(20% off on orders for \$3.00 or more. No C.O.D.)

**The DATAPRINT COMPANY**  
Look Box 322 RAMSEY, N. J.



# When To Listen In

By M. HARVEY GERNSBACK

## All Time Is Eastern Standard

### DAVENTRY

● THE British Broadcasting Co. is building 3 additional transmitters for the Daventry station. Each of these will have a power of about 75 kw. When these are finished the 2 low power transmitters now in operation (15 kw. each) will either be combined to form a single high power transmitter or, what is more likely, they will be left as is and used to transmit to areas relatively near to England. The 3rd transmitter now in use will probably be used for the same purpose. Thus a total of 6 transmitters will be available to be operated simultaneously if the occasion requires it. The new transmitters are scheduled for completion late next spring.

The schedule of operations for July is as follows. Trans. 1: 11:30 p.m.-1:30 a.m. on GSB and either GSD or GSN. Trans. 2: 6-8:45 a.m. on GSH and either GSG or GSJ. Trans. 3: 9-10:30 a.m. on GSG and GSH. GSF will probably be employed as a 3rd wavelength. 10:30 a.m.-12 n. on GSG and GSF. GSH may be used as a 3rd wavelength. Trans. 4: 12:15-3:40 p.m. on GSI, GSD and GSB. GSG may replace one of these 3 wavelengths, however; 3:40-5:45 p.m. on GSG, GSB and GSF. Trans. 5: 6-8 p.m. on GSC, GSF and either GSP or GSG. (GSF may be replaced by GSO at any time.) Trans. 6: 9-11 p.m. on GSD and either GSC or GSF.

### GERMANY

● THE German station is now broadcasting the evening program for N. America on DJB (15200 kc., 19.74 met.) in addition to DJD. DJB also broadcasts for N. America on Sundays from 11 a.m.-12 n.

### R.M.S. QUEEN MARY

● MANY listeners probably heard the new British transatlantic liner Queen Mary broadcasting during her maiden voyage. Her radiotelephone transmitters are more powerful than those of any other ship so that she can be heard more clearly. The call letters of the ship are GBTF. She can be heard on 4.1, 4.12, 8.2, 8.81, 12.34, 13.33, 16.24 and 17.8 mc. Unlike other ships with radiotelephone, however, she is equipped with scrambling devices to render conversations unintelligible thus assuring privacy to the passengers' conversations.

### JAPAN

● THE Japanese are still experimenting with overseas broadcasting. At present a program for Europe is broadcast each Tues. and Fri. from 2-3 p.m. on JVH (14,600 kc.) and JVN (10660 kc.). A program for the east coast of N. America is broadcast on Mon. and Thurs. on JVH and JVM (10740 kc.). A program for the Pacific coast and Hawaii is broadcast daily from 12 m.-1 a.m. on JVH and sometimes JVM. From 4-8 a.m. daily JVM and sometimes JVN broadcast for Manchuria.

### AFRICA

● FIU at Tannanarive, Madagascar, is on daily from about 7 a.m.-10:45 p.m. It operates on about 6015 kc. In Rhodesia two stations are in regular operation broadcasting the same program simultaneously although they are 300 miles apart. They are ZEA at Salisbury on 6000 kc. and ZEB at Bulawayo on 6150 kc. They are in operation on Thurs. from 1:15-3:15 p.m. and Fri. from 10-10:45 a.m., 12 n.-1 p.m. Due to their low power (less than 1 kw.) and the hours at which they operate it is unlikely that they are heard in N. America except on very rare occasions.

### RUSSIA

● A NEW Moscow broadcaster is reported. It is RW96 on 9520 kc. daily at 7 p.m. and on 15,040 or 15,180 kc. on Sun. at 1:30 p.m.

### PHILADELPHIA

● W3XAU will be off the air until approximately August 15th in order to increase the power of the transmitter to 10 K.W.

## NEW BRITAIN

● A NEW station has been heard testing according to reports for "down under." The station is VJZ at Rabaul, New Britain in the East Indies. VJZ operates on about 13700 kc., 21.9 meters. It is heard most frequently from 3-6:30 a.m.

## AUSTRALIA

● VK3ME, 9510 kc., at Melbourne operates daily except Sun. from 4-7 a.m. 3LR, 9580 kc., at Lyndhurst, Victoria, operates daily except Sun., from 3-7:30 a.m. and in addition on Fri. from 10:30 p.m.-2 a.m. (Sat.). VK2ME at Sydney on 9590 kc. operates on Sun. from 12 m.-2 a.m., 4:30-8:30 a.m. and 11:30 a.m.-1:30 p.m.

## Short Waves and Long Raves

(Continued from page 199)

From Fresno, Calif.

wave length, and can receive stations from all over the world. I have received a great many letters from foreign countries. The photo shows me listening to a station.

ED. OLIVES.

Gen. Del. Fresno, Calif.

### A Voice from Kirklin, Ind.

a transformer coupled (233) pentode audio stage. This gives plenty of "wallop" so that the magnetic speaker (changing on the wall inclined sounding board, et al) can be used on all ordinary stations, including EAQ, Madrid; Berlin stations; and Daventry, etc.

PAUL S. GODWIN,

Kirklin, Ind.

### This Month's Prize Winner

used is an 8-inch dynamic. The next receiver is a hand-spread converter using a 2A7 tube. The receiver in the center of the photograph is the famous "Doerle," using a 56 and a 57 as described in the July, 1933, issue of *Short Wave Craft*. At the right, is the old "stand by" battery set, employing two 201A's. All receivers are wired for headphone use, to permit logging at night.

On short-waves, I have verifications from over forty countries, and on the "broadcast" band, I have over two hundred verifications from nine countries.

Here's hoping I'll be the lucky one to win the prize for this month!

A. W. BRADLEY,

35 Hunter St., Toronto (6), Ont. Can.

(Well A. W. B. you win! We hope you enjoy the prize a year's subscription to *Short Wave Craft*.—Editor.)

### "We're the Berries" He Says

S-W "Rx" station with the hope that same will interest your readers.

I am a regular reader of *Short Wave Craft*. This mag. is sure the "berries"—always full of interest and I find your articles most valuable.

Well, I guess I will QRT. 73 to all the "W Hams," and thanks to you, Mr. Editor for your "FB" magazine. Here's to your continued success.

FREDERICK REDWOOD,

"Pembroke" 30, Norwich Road,

Thornton Heath, Surrey, England.

(Thanks, Frederick, for your excellent letter, and your good wishes. We hope our efforts to please the readers will merit your continued interest in *Short Wave Craft*.—Editor.)

One Year's Subscription to  
SHORT WAVE CRAFT  
FREE

for the "Best" Station Photo

Closing date for each contest—75 days preceding date of issue; July 15 for October issue, etc. The editors will act as judges and their opinions will be final. In the event of a tie a subscription will be given to each contestant so tying.

# FREE RADIO CATALOG

This big, all-inclusive radio catalog is yours for the asking. It lists thousands upon thousands of items—anything and everything in radio, for hams, experimenters, service men and dealers. Whatever your needs may be—  
—a 4 or 24 tube receiver, all-wave and short wave mantels and consoles; parts; tubes; kits; accessories; amateur equipment; P.A.—they can be comfortably and economically filled while you sit in your easy chair at home. You will find nationally known, nationally advertised merchandise at lowest WHOLESALE prices—backed by a

FOR EVERYONE



INTERESTED IN RADIO

guarantee of Wholesale Radio Service Co., Inc., the largest radio institution of its kind in the world. This convenient catalog will serve as a handy reference book and shopper's guide to radio. It is thorough—complete—and it brings the world of radio to your door. Back of it all is a competent organization of experienced radio engineers and service men, whose services are available at all times in helping you with your radio problems.

Be sure to get a copy of this helpful catalog for your own use. You will enjoy the assurance of knowing that every single item carries the guarantee of WHOLESALE RADIO SERVICE CO., INC. You will like our service too—the fastest, most dependable service in the field. Five huge, conveniently located branches bring over nite service to most parts of the country—and these five branches are brought to you in the pages of this catalog.

MAIL THIS COUPON TODAY

Wholesale Radio Service Co., Inc. Dept. H-4  
100 Sixth Avenue, New York, N.Y.  
Please Rush catalog by return mail.

Name.....  
Address.....  
Town..... State.....

WHOLESALE RADIO SERVICE CO.  
NEW YORK, N.Y.  
100 SIXTH AVE.  
CHICAGO, ILL. 901 W. JACKSON BLVD.  
ATLANTA, GA. 430 W. PEACHTREE ST. N.W.  
BRONX, N.Y. 547 E. FORDHAM RD.  
NEWARK, N.J. 213 CENTRAL AVE.

Please mention SHORT WAVE CRAFT when writing advertisers

**"COSMAN 4" 5-Band-4 Tube Receiver**



The year's outstanding inexpensive short-wave receiver. Provides hand spread tuning of any signal. Uses two of the new Metal-2's. Built-in Dynamic Speaker. 15-550 meter tuning range. 5-Band switch coil assembly—no plug-in coils. 4" Airplane Dial. Hammarlund Tuning Condenser. Built-in power supply and numerous other features found only in higher priced receivers. Uses four tubes: 2-6K7's; 1-63 and 1-25Z5. A.C.-D.C. Operation. Complete kit of parts and instructions. **\$10.50** Not wired, less tubes and cabinet. **\$2.50** Wired and tested. Extra. **2.25** 4 Matched Sylvania tubes. **2.25** All Metal Crystallized Cabinet for "Cosman 4". **2.25** Send For Our New 1936 Catalogue

**TRY-MO RADIO CO., INC.**  
85 CORTLANDT ST. NEW YORK CITY  
Distributor: Powertone Electric Corp., 179 Greenwich St., N.Y.C.

Internationally popular for its many scientific and technical articles . . .



**EVERYDAY SCIENCE AND MECHANICS** is the finest scientific-technical—mechanical—construction magazine in the field. Up-to-the-minute with news flashes of scientific events. Dozens of constructional articles and many popular experiments. Ideas from which you can make things to sell.

Edited by **HUGO GERNSBACK**  
A Host of Interesting Subjects Covered

Woodworking—Photography—Patents and Inventions—Book Reviews—Metal-Working—Chemistry—Engineering—Microscopy—Electrical Experiments—Household Hints—Astronomy—Prize Contests—and other subjects.

**10c** the copy  
(On all newsstands)

**EVERYDAY SCIENCE AND MECHANICS**  
99-C Hudson St.  
New York, N. Y.

**SPORTS BINOCULAR**

A real high-power field glass that enables you to enjoy such sporting events as Baseball, Boat Races, Horse Races, etc. Most useful on Auto Trips, Hunting, Outings, Beaches, etc. It's a real buy at a fraction of its worth.



PARCEL POST PREPAID **\$1.50**

5 1/2" long, extends to 6 1/2". Lenses nearly two inches in diameter. Black crackle finish. Carrying strap.

Money back guarantee. You can't lose!

**GOLD SHIELD PRODUCTS CORP.**  
17 West 60th St. Dept. S. New York City

**WOMAN'S DIGEST**

OPENS A NEW ERA IN WOMEN'S MAGAZINES. It presents today's most urgent and serious problems for women, besides instructional news, amusing articles, funny travel sketches, prize contests, unusual recipes from all over the world—loads of entertainment and information. Send 10c for sample copy or \$1.00 for the next 5 issues. Sold at better newsstands.

WOMAN'S DIGEST, 99-SW Hudson St., New York City

**High-Gain "Metal-2"**

(Continued from page 203)

band-setting condenser must be at least 3/8 inch or more, in order to prevent short-circuits to the chassis and capacity effects. If 6.3 volts A.C. is to be used for the heater supply, the wire leads to the heater circuits of both the 6J7 and the 6C5 should be twisted to prevent hum; if a 6 volt battery is used the chassis can be used as one lead.

The hand-spread condenser, C2, is set at around 50 or 60 on the dial and the band-setting condenser is rotated until the desired band is found. The 100 mmf. condenser is now set at the center of the band and all tuning is done with the 35 mmf. midget.

This receiver is designed to be operated on a 6 volt storage battery and two or three 45 volt "B" blocks. However, there is no reason for using the storage battery where 110 A.C. is available, as a small transformer supplying 6.3 volts for the heaters is much more inexpensive. The "B" batteries can be used for plate supply or a small power-pack, capable of supplying 90 to 180 volts at 10 or 15 milliamperes may be used. If more than 90 volts is used on the plate of the tube, a resistor of about 2,000 ohms, 1 watt rating, should be connected in series with the cathode lead of the 6C5 to supply bias to the grid of this tube. A paper or electrolytic condenser of from 1mf. to 10 mf., 25 volts rating, should then be connected from the cathode to the chassis. If the electrolytic type is used the end marked positive goes to the cathode of the tube. For 90 volts or less, no bias is needed.

The antenna used with the receiver is only about 20 feet long; a longer wire of at least 50 feet would be much better.

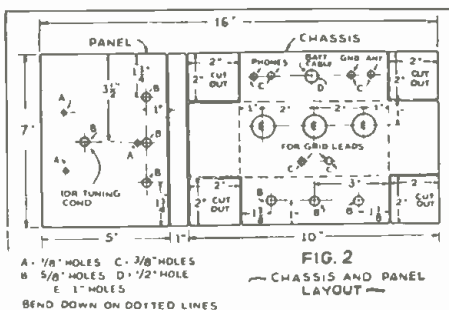

**Coil Data**

Range	Meters	Turns	Spacing	Tap	Wire Size
200-80	52	Close	10		No. 28 D.C.C.
80-10	23	1/16"	5		No. 28 D.C.C.
40-20	10	3/32"	3 1/2		No. 24 D.C.C.
20-10	5	3/16"	2		No. 22 D.C.C.

Coil form—2 1/8" long by 1 1/4" diameter. 5-pin base.

- List of Parts**
- C1 Midget tuning condenser. 100 mmf. (.0001 mf.) Hammarlund.
  - C2 Midget tuning condenser. 35 mmf. (.000035 mf.) Hammarlund.
  - C3 Mica fixed condenser. 100 mmf. (.0001 mf.) Cornell-Dubilier.
  - C4 Mica trimmer condenser.
  - C5 Paper cartridge condenser. 200 volts, .25 mf. Cornell-Dubilier.
  - C6 Mica fixed condenser. 1000 mmf. (.001 mf.) Cornell-Dubilier.
  - C7 Paper cartridge condenser. 400 volts, (.01 mf.) Cornell-Dubilier.
  - R1 Metallized resistor, 1/4 watt, 3 megohms, I.R.C.
  - R2 Metallized resistor. 1 watt, 100,000 ohms, I.R.C.
  - R3 Potentiometer. 50,000 ohms. Electro.
  - R4 Metallized resistor. 1 watt, 250,000 ohms, I.R.C.
  - R5 Metallized resistor. 1/4 watt, 500,000 ohms, I.R.C.
  - L1 Plug-in coil. See text and coil table.
  - SW1, SW2 D.P.S.T. switch.
  - One 7x16 inch aluminum sheet (for panel and chassis).
  - Two "Octal" or 8-prong sockets for metal tubes. Isolantite.
  - One 5-prong socket for plug-in coils. Isolantite.
  - One dial. Bud.
  - RCA 6J7 and 6C5 metal tubes.

**Every Radio "Fan" Needs These SHORT-WAVE RADIO MANUALS**

There has been tremendous progress made in short-waves during the last few years, and only in the OFFICIAL SHORT-WAVE RADIO MANUALS will you find a true picture of the important developments. Whether the advancement has been in set design and construction, servicing all-wave receivers or tube changes, or new scientific discoveries in the short-wave field, all are published chronologically in these SHORT-WAVE MANUALS. The Manuals are edited by Hugo Gernsback and H. W. Secor.

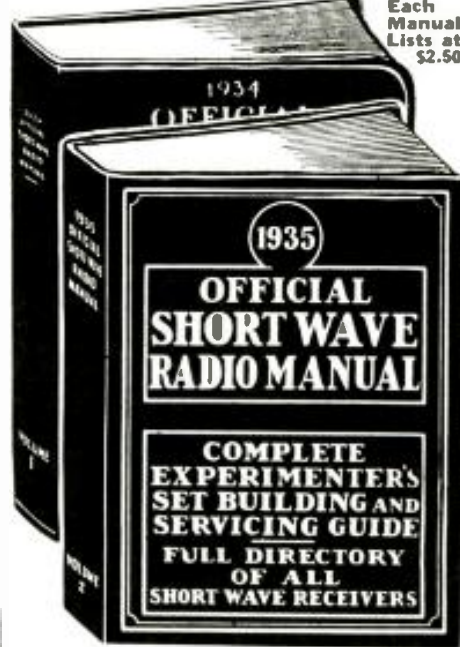

**Contents of the 1935 SHORT-WAVE MANUAL**

Short-Wave Beginners' Section—Short-Wave Receivers—Battery Short-Wave Receivers—"5-Meter" Department—Short-Wave "Artificial Eyer" Apparatus—Short-Wave Experimenters' Section—Extra Short-Waves—Commercial Short-Waves—How to Build "Power Supply" Units—Latest Short-Wave Converters, The Short-Wave Antenna—Superheterodynes—Phone Transmitters for Amateur Stations—"Skip" Distance—Heaviside Layer—Super-Regenerative Short-Wave Receivers—Recording Short-Wave Programs—High Fidelity—Short-Wave Questions and Answers—Short-Wave Kinks—Foreign Short-Wave Review—Tubes for Short-Wave Purposes—Short-Wave Transmitter—Multi-purpose Tubes—Audio Amplifiers—"Band-Bread"—Plug-less "Mono-coil" Receivers—Boosters, Pre-amplifiers and Beat Oscillators—Portable Receivers and Transmitters—Short-Wave Service Data for Radio Service Men.

**Contents of the 1934 SHORT-WAVE MANUAL**

Important Short-Wave Receivers and how to construct them—Short-Wave Transmitters—Building one to seven tube receivers—Coil winding data—Commercial Short-Wave Receivers and Servicing Data—Kinks—Converters and their Construction—Antenna and Noise Eliminators—Superheterodynes—Amateur Phone Transmitters—Short-Wave Physics—theoretical short-wave data—Super-Regeneration in Short-Wave Sets.

**Each Manual Contains Over 240 Pages—1,000 Illustrations**

Flexible, Looseleaf Leatherette Binder 9 x 12 Inches

**Special Combination Offer**

To give every short-wave enthusiast the opportunity to add both SHORT-WAVE MANUALS to his library (Volume 1 and 2) both books, if bought together, can be purchased at a saving. Each Manual sells regularly for \$2.50. If both are bought together, the price is \$4.50. You save fifty cents.

**SHORT WAVE CRAFT**

99-101 Hudson Street New York, N. Y.

SHORT WAVE CRAFT SWC-836  
99-101 Hudson Street, New York, N. Y.

Gentlemen: I enclose herewith my remittance for which send me, postage prepaid, my copy of the OFFICIAL SHORT WAVE RADIO MANUALS as indicated below.

( ) 1934 Official Short Wave Radio Manual—\$2.50  
( ) 1935 Official Short Wave Radio Manual—\$2.50  
( ) Both Manuals—\$4.50.

Name \_\_\_\_\_  
Address \_\_\_\_\_  
City \_\_\_\_\_ State \_\_\_\_\_  
Send Remittance by check, cash, stamps or money order—register letter if cash or stamps are sent.

Please mention SHORT WAVE CRAFT when writing advertisers

# All-Band Transmitting Doublet

(Continued from page 211)

switching from 40 to 20. We mention 40 and 20 although the same system could be used for 20 and 10 with the same combination.

The antenna shown in Fig. 1 will work on all harmonics. There is absolutely no reason why we could not build an antenna of the current fed type for 40 and operate it all the way down to even 5 meters. Of course, for the very short waves a separate half-wave antenna is desirable. But in any case in the band which this antenna operates as two half-waves in



Special "Bud" aerial insulator for doublet feeders.

phase, a considerable advantage is brought about. During experiments and measurements with this type of antenna, it was found that a 40-meter doublet worked on 80 meters as well as on wave-lengths below 40. This statement, of course, is based entirely upon practical experience with the antenna.

The 40-meter doublet was used on the 80-meter band for a considerable length of time, and strange as it may seem, it proved in the particular case in mind to work out better than a 132 foot single-wire antenna, which was end-fed with Zeppelin feeders. No claims are made that this 40-meter antenna operating on 80 is an ideal condition, but we do wish to point out that it is *entirely satisfactory*. The antenna tried out had a length of 33 feet each side for the flat-top section, and a

feeder length of around 50 feet. *Series tuning* was used on 40 and 80 meters and *parallel tuning* on 20.

In designing an antenna, it is a good idea to lay it out on paper beforehand, in order that you will be familiar with just what is going on.

We have marked off the feeder when connected to a half-wave antenna, as shown in Fig. 1, in points  $\frac{1}{4}$  wave apart. In Fig. 2 when operated as two half-waves in phase, we have also marked off the  $\frac{1}{4}$  wavelengths. For each length of the feeders we have shown the type of tuning required. For instance, where there is a current minimum we have parallel tuning, and where the current is maxima we have series tuning. Following this system will enable the builder to construct an antenna with feeders of a convenient length and determine from the diagram which is the best tuning method to use.

We can highly recommend that any amateur using the Zeppelin type antenna, switch to this type and he will undoubtedly experience greater antenna efficiency. We believe this would be true, even though the transmitter might be located near the end of the antenna proper which would necessitate a curvature of the feeding system as shown in Fig. 3. Of course if the shack is located directly underneath the center of the antenna, a more symmetrical system can be maintained.

When making bends or curves in the feed lines, they should be gentle; avoiding all sharp or right-angle bends. Wherever a bend is made, it should be well rounded out and in no case should the feeder lap back toward the antenna. A 90-degree angle is all that may be permitted for satisfactory results.

There are many amateurs who wish to operate on 80, 40, and 20 meter bands, and have experienced difficulty in erecting a 133-foot antenna. This antenna should solve the difficulty, inasmuch as it works apparently as well on 80 meters as on 40 or 20, even though it is only 66 feet long.

Some of our readers may be interested in knowing the complete story of the antenna installation at W2AMN, and for this reason we shall describe the antenna tuning or coupling unit.

This is clearly illustrated in the photograph and in the diagram. First we have a three-pole double-throw switch which changes from *series* to *parallel* tuning. The unique feature of this system is that in the parallel position, the two tuning condensers are connected in series across the coil and feeders. This increases the break-down voltage to twice the value of one condenser, which is a very desirable feature.

This unit is link-coupled to the transmitting amplifier. In another photograph we have shown the ceramic four-point insulator, which is used in the center of the antenna and permits bringing the feeders off at any angle in relation to the flat-top, without causing one of the feed wires to become loose and the other tight and thus throw it out of shape.

This *cross-insulator* acts just like a *swivel* in all directions. The end insulators consisted of 12" straight round insulators, and the lead-ins were brought into the operating room through regular lead-in bushings and insulators.

The antenna wire used was heavy stranded wire (7 strands of No. 20). All of the insulators, including the special double center insulators, are of Bud design, in case the reader wishes to use the identical parts.

### Parts List for Antenna Tuner

- 2—250 mmf. receiving condensers, National
  - 1—2 $\frac{1}{2}$ " ceramic form grooved for 26 turns. National (the wire used on this form was No. 12 tinned copper)
  - 1—7x12x3/16" bakelite panel, I. C. A.
  - 1—3-pole, double-throw switch, I. C. A.
- Special antenna insulators, see text and photos for details.

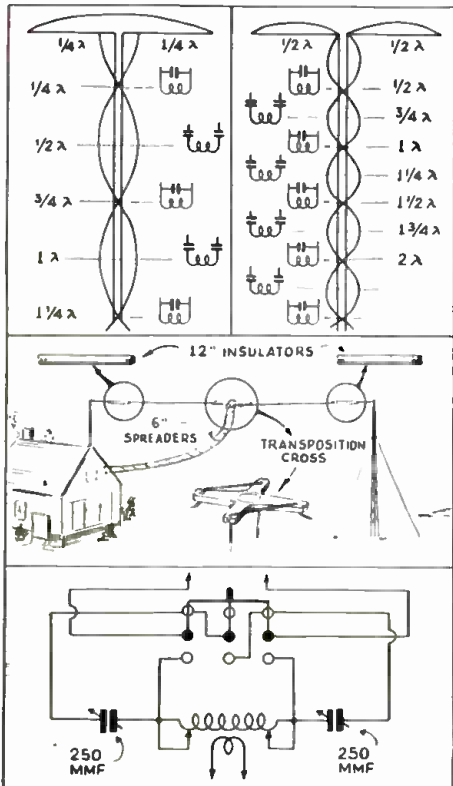

Top—Wave formation on doublet and feeders (1). Center—Use of special new insulator (3), (illustrated above). Below—Switch hook-up for changing from "series" to "parallel" tuning. Fig. 2.

## BRUSH Hand Microphone



For describing athletic events, parades, crowds, etc., from press boxes, balconies, the tops of sound cars, etc., and for commercial interstation, police and amateur transmission work. Priced low. Fits the hand perfectly. Wide frequency response and typical Brush sound cell operation. No button current or polarizing voltage and no input transformer is required.

Size only  $3\frac{1}{4}$  inches x  $1\frac{1}{2}$  x  $\frac{1}{2}$  inches. Weight 3 oz. Output level minus 66 D. B. Shipped complete with 15 feet of cable. Can be furnished on special order with locking type plug and socket for stand connection. Details—Data Sheet No. 8. Free. Send for one.

## BRUSH Headphones



—meet every headphone requirement. Response 60 to 10,000 cycles. No magnets to cause diaphragm chatter. Specially designed cases minimize breakage. Light in weight—Only 6 oz. complete with headband and cords. A quality product at a low price. Details—Data Sheet No. 10. Free. Send for one.

**BRUSH** DEVELOPMENT COMPANY  
1887 E 40th St. CLEVELAND, O.  
ELECTRIC

MICROPHONES • WIRE STANDS • TWEETERS • HEAD PHONES • LOUD SPEAKERS

### The DX2, 2-Tube All-Wave Receiver



A good battery operated receiver that is **GUARANTEED FOR FOREIGN RECEPTION**. Good volume & economical in operation. See article page 601 Feb. 1935 issue SWC. Uses 30-33 tubes as var. detector & power pentode amplifier. Works on 2 dry cells & 1-45V B battery, & 1 C batt. Black shrivel metal chassis & Arcturion tubes. 1.55 extra. Metal cabinet. 1.00 panel. Coils for 12-205 meters & instructions included. CANNONBALL HEADPHONES. \$1.35

Kit assembled & ready to wire. Less tubes, phones, B. C. coils, cabinet, batteries. **4.35** Wired & tested extra. 1.25 Arcturion tubes. 1.55 B. C. coils (2). 1.00 Metal cabinet. 1.00 Special: Complete set, wired ready to use, less phones, batteries, and cabinet \$7.75.

Stamp for Literature  
**CENTRALION ENGINEERING CO.**  
Dept. SW-8 136 Liberty St.,  
New York, N. Y.

## OXFORD NEW SPEAKERS

...with "Changeable Fields" and Universal Transformer, bring you new convenience, performance and economy in Speaker Replacements. Ask your Jobber or Write today for Bulletin 3615.  
**OXFORD-TARTAK RADIO CORP.**  
917 W. VAN BUREN ST., CHICAGO, U.S.A.

## RADIOS..SAVE UP TO 50%

DEAL DIRECT: Factory Price. Many models to select from. AC DC All-wave. Farm, Car and new metal Tube Models. Your name and address on postcard brings you NEW 24 page 1936 Bargain Catalog in colors FREE. Get details of 30-DAY TRIAL plan and Agent User proposition. Goldenstone Radio Co., Dept. 303 8780 Grand River, Detroit, Mich.

30 DAY TRIAL \$6.98 Free Catalog

Please mention SHORT WAVE CRAFT when writing advertisers

# WORLD WIDE ALL WAVE RADIO



**ONE TUBE KIT ONLY \$1.25**

Haven't you always wanted a Real, Powerful Radio Receiver, unscrubbed all your own? A Short and Long Wave set that will actually bring in many foreign stations from all parts of the World, police calls, airplanes, amateurs, etc., as well as your local station. A.C. Radio gives **GUARANTEED RESULTS!** Thousands now in use. Amazing performance!

NOW, the world famous A.C. Construction Kits are priced so low that anyone can afford one! For only \$1.25 we send you, postpaid, every part needed to build a powerful one tube receiver with heavy, attractive metal chassis-panel. Not a feeble crystal set! Works on two inexpensive dry batteries. Later, you can change your set into the Two Tube Battery or All-Electric set at special low cost! You get a valuable radio education by wiring it yourself from our clear diagrams. It's easy for even a child! Just a few simple instructions. Wavelength range 15 to 1000 meters.

**FOR MORE POWER AND VOLUME \$2.00 BUY THE TWO TUBE KIT**

**ALL ELECTRIC TWO TUBE RECEIVER \$3.00**

Tube—75c each. Double headPhone—\$1.15 Any kit laboratory wired and tested—75c extra. REMEMBER!—WE pay the postage! Save! You 15c to 50c or more.

**ORDER NOW! NOT A TOY OR AN ATTACHMENT! ACE RADIO LABORATORIES**  
1619 Broadway Dept. C-3 New York City



## RADIO'S LIVEST MAGAZINE

Edited by HUGO GERNSBACK  
RADIO-CRAFT is devoted to general Radio in all its phases, to Radio Hacking and to the advanced set builder and Radio Technician. Kinks show simple ways out of difficult problems. The latest radio equipment is illustrated and described.

**8 Months for \$1.00**  
RADIO-CRAFT is fully illustrated with photographs, diagrams and sketches. Each issue contains over 150 illustrations. Sample copy—15c.  
**RADIO-CRAFT**  
99C Hudson Street New York, N. Y.

## 6 BACK NUMBERS SHORT WAVE CRAFT MAILED PREPAID 70c

For a limited time only, and as long as they last, we will send you six back numbers of **SHORT WAVE CRAFT** assorted, your choice, for 70 cents.  
The usual price for six copies would be \$1.50 and most publishers charge a higher price for back numbers over one year old.  
We can supply only the following back numbers: Dec. 1930; Feb., April, June, Oct. 1931; Sept. 1932; Sept., Nov., Dec. 1933; Jan., Feb., Mar., April, May, June, July, Aug., Sept., Oct., 1934; 1935—All issues; 1936—All issues to date.  
If you do not specify copies we will use our own judgment in sending assorted numbers to fill your order. Note we cannot exchange the copies for ones that have been sent to you.  
Practically every copy of **SHORT WAVE CRAFT** contains important information that you should have. Here is a chance to get those copies.  
As we have only a small supply of back numbers on hand, this offer will be withdrawn as soon as they have been sold.  
We accept U.S. stamps, U.S. coin, or money order. Rush your order today.  
**SHORT WAVE CRAFT**  
99-101 Hudson Street New York, N. Y.

SHORT WAVE CRAFT x-36  
99-101 Hudson Street, New York, N. Y.

Gentlemen: I enclose herewith 70c. for which you are to send me six back number copies of **SHORT WAVE CRAFT** as follows:.....

Name.....  
Address.....  
City..... State.....

## Midget "Metal-Tube" All-Wave 4

(Continued from page 204)

in place. Then, mount the regeneration control potentiometer at the lower left of the speaker and the station selector variable condenser at the lower right. The two-section dry electrolytic condenser which is in a cardboard container, is mounted on the rear of the panel at the right. The antenna trimmer is mounted on the rear chassis wall with a Fahnstock clip soldered to one terminal for making connections to the antenna. The 300 ohm filter choke is fastened to the rear of the panel at the center, below the chassis deck.

There are eight small resistors and four small fixed condensers below the chassis. These are soldered directly to the terminals of the sockets and other parts with which they are to function. The grid-leak and grid condenser can be seen near the variable tuning condenser. The .0005 mf. mica condenser from the B plus terminal of the tickler winding of the plug-in coil is soldered in place directly below the coil socket. Practically all the wiring is performed below the chassis deck. The only wire visible from the top is the connection which goes from the grid-leak and grid condenser to the control grid of the 6J7 tube. This wire terminates in a clip which fits over the cap of the tube.

The "foreign" stations come in on the dynamic speaker with real volume and, as mentioned above, the fine selectivity is a source of surprise. For the benefit of those who missed the preceding article on the Midget A.C.-D.C. "glass tube" set, (See Dec. 1935 issue of *Short Wave Craft*) it might be mentioned that this entire set is only 6"x6"x4" deep.

### Complete List of Parts Required for the Midget Metal Tube All Wave Four

- C1—Equalizer Antenna Trimmer, 2 to 30 mmf., Hammarlund type MEX
- C2—140 mmf. Variable Tuning Condenser, Hammarlund, type SM-140 "Star"
- C3—.0001 mf. Mica Condenser, Cornell-Dubilier, type 3L
- C4—.1 mf. 400 volt "Cub" Tubular Condenser, Cornell-Dubilier, type BA-4P1
- C5—.0005 mf. Mica Condenser, Cornell-Dubilier, type IW
- C6—.01 mf., 400 volt "Cub" Tubular Condenser, Cornell-Dubilier, type BA-4S1
- C7—8 mf., 200 volt Tubular Electrolytic Condenser, Cornell-Dubilier, type ED-7080
- C8—.1 mf., 400 volt "Cub" Tubular Condenser, Cornell-Dubilier type BA-4P1
- C9—.01 mf., 400 volt "Cub" Tubular Condenser, Cornell-Dubilier, type BA-4S1
- C10—5 mf., 50 volt Tubular Electrolytic Condenser, Cornell-Dubilier, type ED-3050
- C11—.01 mf., 400 volt "Cub" Tubular Condenser, Cornell-Dubilier, type BA-4S1
- C12, C13—Dual Section Dry Electrolytic Condenser, cardboard container, 16 mf. and 8 mf., 150-200 volts, Cornell-Dubilier, type MA-11261
- R1—1 meg., 1/2 watt I.R.C. Metallized Resistor
- R2—1 meg., 1/2 watt I.R.C. Metallized Resistor
- R3—170,000 ohm, 1/2 watt I.R.C. Metallized Resistor
- R4—1 meg., 1/2 watt I.R.C. Metallized Resistor
- R5—75,000 ohm Electrad Potentiometer with Switch (Sw1) type 202-S
- R6—25,000 ohm, 1/2 watt I.R.C. Metallized Resistor
- R7—1500 ohm, 1/2 watt I.R.C. Metallized Resistor
- R8—170,000 ohm, 1/2 watt I.R.C. Metallized Resistor
- R9—1 meg., 1/2 watt, I.R.C. Metallized Resistor
- R10—600 ohm, 10 watt vitreous enameled resistor, Electrad
- R11—180 ohm, 50 watt resistor in line cord
- L1—One set of 4-Prong short-wave coils, 17 to 270 meters, Hammarlund type SWK-4
- L1—One 4-Prong broadcast Coil, 250 to 560 meters, Hammarlund type BCC-4
- One 4-Prong wafer socket for L1
- Four "Octal" sockets for V1, V2, V3, and V4
- V1—6J7 Metal Tube, RCA Radiotron
- V2—6C5 Metal Tube, RCA Radiotron
- V3—25A6 Metal Tube, RCA Radiotron
- V4—25Z6 Metal Tube, RCA Radiotron
- HP1—Fahnstock antenna clip
- CH1—300 ohm, 30 henry audio filter choke, Thordarson
- 1—5" Dynamic Speaker with 2500 or 3000 ohm field and 4500 ohm output transformer
- 1—Metal Chassis, Blan, 6"x4"x1 1/2" deep
- 1—Aluminum Panel, Blan, 6"x6"x1/16" deep
- 2—Crown knobs

## Extraordinary Bargains!

No. 227 tested and guaranteed tubes, 10 for \$1.00  
Metric spark plugs, made in France for U. S. Government aviation engines, brand new, suitable for modern high powered autos, motor boats, etc.  
Visor Cab. Just the thing to use during the hot Summer days. 15c each, 10 for \$1.00  
Luminous Gear Shift Balls. In beautiful transparent colors, with your initial made of nickel silver with blue enameled background. 25c each, 5 for \$1.00  
Sun-Mite, Sr., ultra violet carbon sun lamp, with base. \$1.98 each  
Sun-Mite, Jr., screw-in type, which utilizes an ordinary floor or table lamp for support. \$1.49 each  
U. S. Auto Compass, always shows you clearly in which direction you are traveling. \$1.98 each

**GOLD SHIELD PRODUCTS CORP.**  
17 West 60th Street New York City

# INVALUABLE

## SHORT WAVE COIL BOOK

**Short Wave Coil Data for Every Conceivable Short Wave Receiver**

**Price 25c**

**RADIO PUBLICATIONS**  
97 Hudson Street  
NEW YORK

## SHORT WAVE SET BUILDERS MUST HAVE THIS BOOK

It is now possible for the experimenter and short wave enthusiast to obtain the most exhaustive data on short wave coil winding information that has ever appeared in print.  
As every experimenter who has ever tried to build a short wave set knows only too well by experience, the difference between a good and a poor receiver is usually found in the short wave coils. Very often you have to hunt through copies of magazines, books, etc., to find the information you require.  
Between the two covers of this book you now find every possible bit of information on coil winding that has appeared in print during the past two years. Only the most modern "kinks" has been published here.  
No duplication. Illustrations galore, giving not only full instructions how to wind coils, but dimensions, sizes of wire, curves, how to plot them, by means of which any coil for any particular short wave set can be figured in advance, as to number of turns, size of wire, spacing, etc.  
There has never been such data published in such easy accessible form as this.

**FRIENDS PESTER HIM**  
Dear Sirs:  
I received your Short Wave Coil Book and am very well pleased. I showed it to my radio friends and now they are always pestering me for coil data. hi hi!  
**BERNARD A. DECKELMANN,**  
11348 So. State St., Chicago, Ill.

**RADIO PUBLICATIONS**  
97 Hudson Street, New York, N. Y.

Radio Publications, 97 Hudson Street, New York, N. Y. 8-36

Please send immediately, your Short Wave Coil Book, for which I enclose 25c herewith (coin, U. S. stamps or money order acceptable). Book is to be sent prepaid to me.

Name.....  
Address.....  
City and State.....

Please mention **SHORT WAVE CRAFT** when writing advertisers

## Improving the 2-Volt Superhet Receiver

(Continued from page 210)

be disturbed; if the tickler is wound in the opposite direction, it can be properly "phased" by reversing the plate and "B" positive leads until oscillation is secured. The coil is given a coat of coil "dope" and allowed to dry before reassembling the transformer.

After carefully experimenting with the mixer and the oscillator coils, it was found that the small padding condenser across the oscillator tuned circuit could be removed with no effect on the tracking. The regeneration control also proved to be an effective volume control so the 50,000 ohm potentiometer in the screen-grid circuit of the 1C6 was removed and the 250,000 ohm unit installed in its place on the chassis. The band-change switch is mounted in the hole left vacant by the small padding condenser.

### Re-Aligning I.F. Stages

The next step is to realign the I-F circuits as the regeneration will have some effect on the adjustment of both the *grid* and *plate* circuits of the output transformer. Set the regeneration control just below the point where oscillation begins and rotate the tuning dial until a *weak signal* is heard. Adjust the tuning controls until the set is operating as close to the center of the carrier as possible and then turn the adjusting screw of each I-F trimmer until maximum volume is obtained. Always "peak" each trimmer before going on to the next and do not disturb the tuning controls or turn the volume up or down during this process. This type of adjustment is for the reception of both phone or broadcast and code stations, the regeneration control being turned above the point of oscillation for receiving code or locating the carrier in exactly the same manner as in the ordinary regenerative receiver. When the control is reset just below oscillation, the I-F circuits are in the "peaked" position where maximum amplification is obtained.

### Close Approach to Single-Signal Selectivity

Where the receiver is to be used for *code* work exclusively, a close approach to *single-signal selectivity* can be had by simply turning the regeneration control full-on and aligning the trimmers of the output transformer with the second detector oscillating. This method is extremely critical in the adjustments, but it gives much better *selectivity* on code. The tuning controls are set for "zero beat" with a weak signal as outlined above before any of the I-F circuits are adjusted. Unfortunately, this method cannot be used where the reception of broadcasting stations is desired, as the I-F stages will go out of alignment when the regeneration control is turned down.

When properly adjusted, using either method, the regenerative second detector will increase the sensitivity of this receiver at least 20% or more. A little experience with the circuit will teach the experimenter just where to set the regeneration control for best results. It is likely that a high noise level will be encountered when the detector is operated precisely on the point of oscillation, although this condition disappears when the control is set above or below this spot.

### New Method of Changing Coils for Different Bands

The second improvement in the design of the 2-volt superhet is the new method of changing the oscillator and mixer coils. As shown in Fig. 3, the new coils are of the familiar *tapped* variety, the taps being brought out to the pins of a standard 7-prong coil form, instead of going directly to the coil switch, as is usually done in circuits of this type. This arrangement does not confine operation to one set of coils and allows the receiver to be used on even the very *long* wave bands if desired. The coils shown in the drawing cover the

short waves from 14 to 130 meters on three positions of the coil switch as follows: Position "one" 14 to 28 meters; position "two" 28 to 51 meters; position "three" 50 to 130 meters. A second set of coils will allow reception on the 130 to 200 meter band and the standard 200-600 meter broadcast band on three positions of the switch. Thus only two sets of coils are required for complete coverage of all wavelengths between 14 and 600 meters in six bands! Furthermore, by simply placing the switch on position "three" and inserting a regular plug-in coil in each socket, *the switch and all its taps are removed from the circuit*. Therefore, either method of band-changing can be used at will and some interesting comparisons between the two systems made at any time.

In winding the oscillator coil, the tickler is wound at the bottom of the form first of all. The grid coil is then wound in the same direction and is spaced and tapped as shown in Fig. 3. The various sections of the coil and the tickler are close wound. All wiring from the taps to the pins of the 7-prong form and socket should be as short and direct as possible in order to prevent undue losses and oscillator instability. The mixer coil is wound in exactly the same manner as the oscillator coil except that more turns are required. Of course no tickler is used in this circuit. Complete data on both coils can be obtained from Fig. 3.

### Extra Parts for Revamped 2-Volt Super

- 1 Triple-pole triple-throw coil switch
- 2 7-prong coil forms, ribbed type, I.C.A.
- 2 7-prong spring-mounting sockets, Isolantite.
- 1 250,000 ohm potentiometer, Eleetrad.
- 1 1-mf. metal case paper by-pass condenser, 300 w.v., Cornell-Dubilier.
- 1 supply of No. 32 enameled silk-covered magnet wire, for winding tickler on the 2nd I.F. transformer.

[See article on 2-volt super in the July 1936 *Short Wave Craft* for additional parts.]

## A Strong, Easily-Made Hole-Cutter

(Continued from page 211)

Of course the square hole and the two smaller holes that hold the cutting tool should pass squarely through the center and not slanting. Use a reasonable amount of care in laying out and boring all holes and things will work out all right.

This cutter will stand all the work it is called on to do. You can tighten up on the nuts without breaking anything and once tightened the cutting tool and shank will not slip. The cutting tool can be separately turned and adjusted in its hole without disturbing the shank. The cutting tool being round can be turned to give it the correct clearance needed, a feature not possible in commercial cutters using a square cutting tool.

The pilot on the shank is not hardened. If drill rod cannot be obtained easily an old three-sixteenth diameter drill can be broken off about two and one-half inches in length, softened and filed to correct cutting and clearance shape, re-hardened and used. In hardening, the tool is heated to bright red, polished with emery cloth or sand paper and then carefully reheated by holding it a few inches from a very small flame until the polished tool begins to turn to light straw color, which in turn changes to a darker straw color. When this color is reached plunge it into water. In reheating to color, do not hold the point in the small flame, but the part about one inch above the point, and the color will run down to the point. It must be done carefully, as all hardening is done.



## HRO JUNIOR SUPERHETERODYNE

The HRO Junior is a superheterodyne receiver, outstanding for its excellence and low price. It is designed expressly for those who are interested in world-wide short wave reception and who demand the performance of a commercial-type receiver, but do not require the highly specialized features that necessarily increase the cost of a receiver designed expressly for two-way commercial service.

A fine tube circuit (including two stages of preselection and two stages of I.F., with air dielectric trimming condensers), a precision built tuning condenser, separate shielded coils, and strict adherence to National's high standard of quality permits the attainment of unsurpassed selectivity and sensitivity. Laboratory calibration of each coil range, plus the unique easy-reading tuning dial (no perplexing intermingled tuning scales) provides an accurate means for logging and locating stations. Fast or slow tuning is accomplished by the clever arrangement of the tuning drive mechanism. Only one knob is used—no unwieldy double or two-position knobs.

For those desiring the specialized features of a crystal filter, 8 meter and amateur band spread, we recommend the standard HRO!

Write for an illustrated description of both receivers.

**NATIONAL CO., INC.**  
MALDEN, MASS.

## "Do You Know the Answer?"

How to Go About Looking for a Job?

How to Better Your Position? How to Plan Your Career?

The answer to these and many other questions, such as: How to earn money in spare time jobs, what occupation to choose, inside stories of how the other fellow has done it, statistics, facts, will be found in the new monthly magazine

## JOBS & CAREERS

For Sale at all Newsstands NOW.

Leading articles by vocational experts, personnel directors, leaders of industry tell you how to tackle your problems and how to increase your chances of success.

IF YOU WANT TO LEARN WHY MOST FELLOWS FAIL, WHERE OTHERS SUCCEED, READ

On all Newsstands 25c a copy.

If your dealer cannot supply you, send a quarter and we will forward a copy at once.

## JOBS & CAREERS

520 N. Michigan Avenue, SW8, Chicago, Ill.

## \$1 MODERN SLIDE RULE \$1



With A-B-C-D Scales. 6" Long—Thin Construction Fits In Vest Pocket. NO WOOD OR CELLULOID. Sold \$1 M.O. and receive rule with instructions and genuine leather case by return mail. H. Bieher & Company, 59 Pearl St., New York, N. Y.

Please mention *SHORT WAVE CRAFT* when writing advertisers

The chassis used measure 8 by 12½ by 3 inches, and are ordinary thin wall steel chassis, available at any radio store. These can easily be drilled because of the lightness of the material. Looking at the transmitter from the front, we find that the oscillator chassis is on the right, and the amplifier chassis is on the left.

On the oscillator chassis is mounted the coils, tuning condensers, and resistors associated with that circuit. The top view shows that we use the large variable condenser for the cathode tuning. On the right, and directly behind it, we have a cathode coil; in the center of the chassis we have the tube, and behind it the quartz crystal. To the left of the tube, we have the plate tuning condenser in the front, and the plate-coil in the rear. Along the front edge we have on the right, below the cathode condenser, the B negative switch which turns the oscillator on and off. On the left-hand side of the chassis, below the plate condenser, we have the jack through which the meter readings are taken for both the plate current and screen current combined.

**Amplifier**

Next we go to the amplifier chassis on the right of which we have the grid coil in the rear, and the grid tuning condenser toward the front. In the center we have the two tubes. Behind them is located the neutralizing condenser, and finally on the extreme left, we have the plate coil and the plate tuning condenser, which is of the split-stator variety. Along the front edge of the amplifier panel, we have four jacks—one for the key and the other three for reading the grid current, screen current, and plate current.

In the power supply, we have in the rear right-hand corner, the 400 ma. plate transformer, in front of it is the combination filament transformer, with the four filter condensers along the front edge, and behind them the rectifier tube and the

**The "Beam Tube-3"  
An Astonishing  
Transmitter**

(Continued from page 209)

**Chassis Details**

heavy-duty filter choke. Along the front edge of the power supply, we find two toggle switches and two sockets. The switches are for turning on the plate and filament transformers separately—a very desirable arrangement. The two sockets are wired in parallel, except for the high voltage connections. The socket to the right is used for the oscillator and from it we obtain the B plus and B negative connections supplying 250 volts to the oscillator, and 6.3 volts for the filaments. The other socket to the left is wired exactly the same and the amplifier plugs into it. But here we have the full output voltage of the power supply—around 600 volts. The filament transformer has three windings—one 5 volts; one 2½ volts; and one 6.3 volts. The 5 volt winding is used for the rectifier while the 6.3, of course, is used for the 6L7's.

**Condenser Input Used in Power Supply**

Returning to the circuit, we find that condenser input is used in the power-supply and on each side of the choke we have two 8 mf. condensers connected in series resulting in a capacity of 4 mf. each side. Condenser input was used in order to boost the voltage. That is why the transformer, although rated at only about 550 volts, delivers 600 under full load.

Link coupling is used between the oscillator plate circuit and the amplifier grid circuit. The link coils are wound directly on the form with the plate and grid windings. The coil data given at the

end of this article will cover the 80, 40, and 20-meter amateur bands, and no "cut and try" will be necessary.

When operating a transmitter on the crystal frequency, the cathode tuning condenser plates are fully meshed and by simply bending a small portion of one corner of one rotor plate, the condenser automatically becomes short-circuited, and the tube then operates as a straight tetrode oscillator. Adjustment of the transmitter is exactly the same as for any other transmitter of similar design, except that when the amplifier has been finally loaded and slight adjustments are made in the oscillator circuit or the grid circuit of the amplifier, the plate current will decrease as the point of maximum excitation is approached, instead of increasing, as would be the case if fixed bias were employed on the amplifier.

**Coil Data for Beam Tube Transmitter**

Osc. Cath.	Osc. Pl.	TURNS Amp. Grid	Amp. Pl.	Neut. Tap.
10	18	80 METERS 18	20	6
4	12	40 METERS 12	12	4
None	5	20 METERS 5	6	2

All coils except the 40 and 20-meter amplifier tank coil are close wound with No. 16 D.S.C. copper wire. The 40 and 20-meter plate coils are wound with the same size wire, and the winding is spaced to a length of 2½ inches. The 40-meter cathode coil is only used when a 40-meter crystal is employed.

The link coils have two turns each, close-wound and spaced approximately 3/16" from the cold end of the tank coils. All coils are wound on 5-prong forms, having a diameter of 1½" and are 3½" long, except the amplifier plate tank coils, which are wound on forms having a 2¼" diameter and a length of 3½ inches.

**YOU CAN'T BUY THIS BOOK**

**SHORT WAVE GUIDE**

Published by **SHORT WAVE CRAFT**  
99 HUDSON STREET  
NEW YORK, N. Y.

The special subscription rate is 7 months for \$1.00. (Regular newsstand rate is \$1.75.)

Send the coupon today, with your remittance of One Dollar (\$1.00). When your subscription is received, a copy of our SPECIAL ANNIVERSARY GIFT will be sent to you—POSTPAID.

You do not have to be a new subscriber to receive this gift. If you are a subscriber at present, a copy of "SHORT WAVE GUIDE" will be sent you upon receipt of \$1.00, and we will advance your subscription by seven months.

**With Your \$1.00 Subscription to Short Wave Craft You Get This Brand New FREE Book.**

The size of **SHORT WAVE GUIDE** is 5 1/2 inches—with over a hundred wiring diagrams and photographs.

because it is our  
**Sixth Anniversary**  
**FREE GIFT to YOU!**

This year, SHORT WAVE CRAFT celebrates its Sixth Anniversary. Annual increases in circulation, plus authentic, exclusively short-wave editorial material, makes SHORT WAVE CRAFT unquestionably the leading magazine in its field. To commemorate this notable occasion, the Editors have written this outstanding book.

**Partial Contents of Short Wave Guide**

- Short-Wave Questions and Answers**  
It is impossible to publish each month in SHORT WAVE CRAFT all the questions (and their answers) sent to us. We have printed with full illustrations, in SHORT WAVE GUIDE hundreds of important questions which have been recently received.
- Best Aerials for Short-Wave Reception**  
The many elaborate antennas suitable for short-wave receivers often present problems for set owners. SHORT WAVE GUIDE will help you decide which aerial is best for your receiver. Many types of antenna are illustrated.
- Practical Hints on Short-Wave Tuning**  
Hundreds of short-wave stations are heard by fans—and hundreds more could be heard distinctly if only you knew more about tuning them in. Expert advice on proper tuning is included in SHORT WAVE GUIDE.
- "Police Call" Receiver and How to Build It**  
The most stirring signals on the air are police calls and every fan wants to hear these exciting alarms. Complete details for building and operating a "police call" receiver will be found.
- A Simple "Ham" Transmitter**  
There are thousands of fans who want to build a simple transmitter. Here is the ideal transmitter for beginners. It is practical, yet inexpensive to construct. List of necessary parts, wiring diagrams, and construction details are included.
- Simple, Efficient Short-Wave Receivers Which Anyone Can Build**  
Complete constructional plans for building many 1, 2 and 3-tube receivers will also be found. Schematic diagrams, lists of parts—everything you need to know to build these sets and make them function properly is included.

**SHORT WAVE CRAFT, 99G Hudson Street, New York, N. Y.**

Gentlemen: Enclosed you will find my remittance of ONE DOLLAR (\$1.00) (Canada and Foreign \$1.30) for which enter my subscription for Seven Months to SHORT WAVE CRAFT. You are also to send me absolutely FREE, and postpaid, a copy of the Special Anniversary Gift Book—SHORT WAVE GUIDE.

Name .....

Address .....

City .....

State .....

New Subscriber  Old Subscriber

Send remittance in form of check, money order or unused U. S. Postage Stamps. (Foreign: International Postal Money Order.) Register letter if it contains cash or stamps.

Please mention SHORT WAVE CRAFT when writing advertisers

# The Hammarlund "Super-Pro" Receiver

(Continued from page 214)

constitute the input circuits of the three 6D6 I.F. amplifier tubes. A 4th transformer, directly behind the first three, couples the output of the third I.F. tube to the control grid of the 6B7 second detector.

Since the pentode section of the 6B7 second detector amplifies at intermediate frequency, it really constitutes a fourth I.F. stage. Its plate circuit is coupled back to its diode plates by means of a fifth twin-tuned transformer, similar in design to the fourth or detector input transformer. The coupling between primary and secondary of this detector output transformer is also variable by means of a knurled nut on the top of its shield.

## 10 Tuned Circuits in I.F. Amplifier

Altogether, the I.F. amplifier has ten tuned circuits arranged in five pairs, three pairs of which may have their coupling continuously varied from the front panel, while the coupling of the remaining two pairs may be adjusted from inside the receiver to suit various service conditions met with in the field.

All the intermediate transformers, AVC transformers and the beat-oscillator circuit are tuned by means of special dielectric variable condensers. This insures stability of both gain and selectivity even under adverse atmospheric conditions.

## New Tuning Dial Features

The tuning dials are laminated translucent celluloid with the scales printed on the

center lamination. Each dial is brightly illuminated from the rear, affording quick and accurate settings. The main tuning dial has five ranges as follows: 540-1160 kc., 1160-2500 kc., 2.5-5.0 mc., 5.0-10.0 mc., and 10.0-20.0 mc.

Only one scale is visible at a time. A slotted black mask controlled by the band-changing switch knob automatically exposes the scale corresponding to the frequency range for which the switch has been set. Both dials are rotated smoothly and easily by friction drives, entirely free from any backlash. The knob drives have a ratio of 12 to 1, requiring approximately five and one half turns to cover a complete frequency range. The band-spread dial is calibrated in 100 equal divisions. Due to the circuit used for band-spreading, its readings are almost exactly straight-line frequency. Consequently the kilocycles per scale division remain practically constant from 0 to 100.

## Power Supply a Separate Unit

The power supply is an entirely separate unit in which two rectifiers are used. A 5Z3 is used for the plate voltage and a 1V for the grid voltage. This unit supplies individual C bias and B voltage. Due to the special filtering system employed, positively humless output is available. This unit is connected to the receiver by way of a special 10-lead cable. The speaker field connections are also obtained from this unit.

In our next article, we will discuss the audio system, AVC unit, and the special crystal filter, etc.

# New All-Around Test Meter

(Continued from page 216)

Just below the meter, and connected directly across it, is a variable 40 ohm shunt which is out of the circuit when the control knob is fully advanced.

A toggle switch is provided in the lower right hand corner to turn the filament battery (contained in the cabinet) on or off. Seven plug-in coils are furnished: one for each amateur band from 5 to 160 meters and a VT voltmeter coil which contains a jumper but no winding.

## Uses of the RigChecker

**Field Strength Meter:** This is one of its most valuable uses as it indicates power actually in antenna.

Re-radiation and resonance in guy wires, etc., may be checked by bringing the checker near them (using short antenna pick up wire).

**Warning:** Relative meter deflections at different frequencies mean nothing as the standing waves in the antenna field will shift with frequency changes. They can be traced by walking about with the checker tuned in resonance.

On very low power transmitters greater sensitivity can be obtained by placing a shorting jumper on phone plug and inserting in phone jack.

**Monitor:** With phones plugged into phone jack and fil. switch "on" the instrument may be used as a monitor to check voice, key clicks or carrier hum.

**Over-Modulation Indicator:** the instrument will indicate over modulation or frequency shift.

**Wave Meter:** The six coils may be indi-

vidually calibrated, by one of the methods described in the handbooks, to serve as frequency meters on the various amateur bands. When used thus the fixed 10-in. pick-up wire should always be used.

**Tuning Indicator for Receiver and "R" Strength Meter:** The variable meter shunt should be turned full to the left (shorting meter) and the meter inserted in series with the plate lead to one of the I.F. tubes having maximum A.V.C.

**V.T. Voltmeter:** Can be used for either A.F. or R.F. measurements where a slight circuit load can be tolerated.

The sensitivity depends upon the resistance that is used across the instrument phone jack. With no plug in jack (10,000 ohm resistance is across it) the reading will be from 0 to 17 volts with a practically linear scale. Thus .5 on the meter will be 8.5 volts; .2 on the meter would be 3.4 volts (17 x .2), etc.

With the 100,000 ohm resistor inserted in the phone plug and plugged into the jack, the meter scale will read from 0 to 100 volts.

**D.C. Voltmeter:** Reads 0 to 10 volts with no plug in phone jack (Move decimal point of meter reading one place to the right). 0-100 volts with 100,000 ohm resistor connected in phone plug and inserted in jack (move decimal point on scale 2 places to the right) 0-1000 volts with 1,000,000 resistor in plug. (Move decimal point on scale 3 places to right.)

This article has been prepared from data supplied by courtesy of Radio Constructors Laboratories.

microphones. As many as four velocity microphones can be fed into one transformer. Hum pickup is entirely eliminated by the hum neutralization design of the transformer. An alloy case is used which will withstand a great deal of mechanical abuse. Only a few seconds is required to connect the input of the transformer to the microphone—and a single conductor shielded cable is supplied for the output. Either a 50 or 200 ohm microphone can be fed into the standard input impedance of 200 ohms. Other impedances obtainable.

This article has been prepared from data supplied by courtesy of Amperite Co.

## External "Mike" Input Transformer

(Continued from page 214)

microphones directly into amplifiers having high impedance input. It permits the cable of the low impedance microphone to be any length up to 2,000 feet. Makes high gain amplifiers immediately adaptable to any location. Equal output is obtained by the use of this specially designed transformer and the low impedance velocity as is obtainable with high impedance

## Tune with Your Eye



An "RCA Cathode Ray Kit," easily installed on any receiver having Automatic Volume Control, makes your set tune like a '36 model. Kit, including tube, socket, escutchcon, cable, everything needed, only \$3.00. Stock No. 9688.

## New RCA Spiderweb Antenna



Gives improved pick-up on all bands with noise-reduction on short waves. Functions as a T from 140 to 4,000 kc., multiple tuned doublet 4000 kc. to 23 megacycles. Completely assembled, soldered, \$8.95. Stock No. 9685. Kit extending range to 70 mcs., \$1.50. Stock No. 9689.



See your dealer or write to Parts Division

RCA Manufacturing Co., Inc.  
Camden, New Jersey  
A Service of Radio Corporation of America

# New! 1936 EDITION

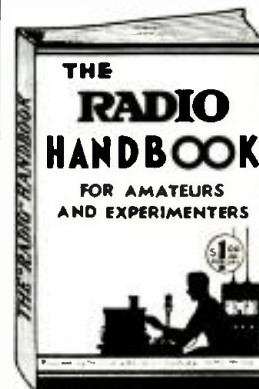

360 PAGES  
OVER 400

ILLUSTRATIONS  
AND  
DIAGRAMS

Complete  
Radio Course  
AND  
Valuable  
Reference  
Guide

- ★ Amateurs and experimenters "awear" by the facts in this new Handbook. No space has been wasted on matter which is not of practical use. Nothing of value has been omitted. The book is concise, to the point and profusely illustrated. PARTIAL LIST OF CONTENTS: Learning the Code, Fundamental Theory of Electricity, Theory of Vacuum Tubes, both receiving and transmitting, Receiver Design, Crystal Filters, A.V.C., Audio Circuits, Construction and Operation of transmitters, Famous Jones Exciter, Numerous Coil Winding Charts, Radio Telephony, Controlled Carrier Modulation, Complete 53 page chapter of 10 Meter and Ultra-High Frequency Equipment, Complete 25 page chapter on All Types of Antennas, Power Supplies, Test Instruments, Cathode Ray Oscilloscope and Its Application to Short-Wave Receivers and Transmitters, Regulations of the Federal Communication Commission and Board of Fire Underwriters, Complete List of "Q" Signals, etc., etc. Size 6"x9", Flexible card-board covers.
- ★ ORDER TODAY. Send \$1.00 plus postage (weight, 2 lbs.). Check or money order accepted. Register letter if you send cash or unused U. S. postage stamps.

## RADIO PUBLICATIONS

101 Hudson Street

New York

Please mention SHORT WAVE CRAFT when writing advertisers

# SPRAYER OUTFIT

ELECTRICAL—PORTABLE

**\$32.50** Complete with Gun, ready for Service



This is the ideal Outfit for all around spraying work wherever Current is available. Sprays everything: Lacquers, Oil, Cold Water Paints, Enamels, Varnish, Insecticides, Disinfectants, Shoe Dyes, etc. The Unit is compact, completely self-contained.

Ideal for spraying Furniture, Radiators, Screens, Machinery, and other maintenance paintings in Homes, Schools, Clubs, Hospitals, Stores, Factories, and office Buildings.

The Gun furnished with this Unit is of Pressure Cup type; requires but 2 cu. ft. of Air per minute. Has Bleeder type construction which assures uniform pressure at all times without clogging the Air Passage which is easily cleaned. Furnished with 3 Nozzles which produce Fan, Round, and Right Angle Spray respectively.

Complete Unit consists of Air-cooled Compressor with machined Fan-cooling Pulley, V-Belt Drive; Pressure type Gun with 1 quart Aluminum Paint Cup; 3 Tips; 1/4 H.P. Heavy Duty Motor, 110/120 volt, 60 cycle, AC; 15 ft. rubber covered 2 Ply Air Hose; 8 ft. Cord & Plug; Filter Tank; Entire Unit mounted on Base with Ball Bearing Casters.

A low priced Power Sprayer; the kind of Machine that usually sells for \$50.00 to \$60.00.

Price of complete outfit, shipping weight, 60 lbs.	<b>\$32.50</b>
Price of outfit complete, less Motor, shipping weight—35 lbs.	<b>\$25.50</b>
Price of Gun only with 3 nozzles, shipping weight, 7 lbs.	<b>\$7.50</b>
Price of Compressor only, shipping weight 15 lbs.	<b>\$9.50</b>

**Our Old Customers Know That Our Merchandise Is Sold on a Strict Money-Back Guarantee**

All Shipments will be forwarded by Express Collect if not sufficient postage included with your order.

**WELLWORTH TRADING CO.**  
560 W. Washington Bd. Dept. SW-836, Chicago, Ill.

## MAILING LISTS



GET OUR FREE REFERENCE BOOK and MAILING LIST CATALOG FREE

Gives counts and prices on accurate guaranteed mailing lists of all classes of business enterprises in the U. S. Wholesalers—Retailers—Manufacturers by classification and state. Also hundreds of selections of individuals such as professional men, auto owners, income lists, etc. Write today for your copy

**R. L. POLK & CO.**

Polk Bldg.—Detroit, Mich.  
Branches in Principal Cities

World's Largest City Directory Publishers  
Mailing List Compilers, Business Statistics, Producers of Direct Mail Advertising.

# Ultra Short Wave Super-het

(Continued from page 207)

is proportional to this value, provided that the external damping is negligible. This means that the efficiency of the coils must be high and their inductance must be as high as possible—which necessitates the reduction of stray capacities to a minimum. If the capacity of a tuned circuit can be cut in half, the inductance can be doubled and this increases both the L/C ratio and the dynamic resistance of the tuned circuits, with a resulting increase in gain for the stage.

Unfortunately, tubes have a rather low input resistance at these frequencies—sometimes as low as 5,000 to 20,000 ohms. When it is realized that the dynamic resistance of the tuned circuit may be no greater than this value, the difficulties in the path of obtaining high amplification can be understood. Also, because of the high frequencies, feed-back effects are much more serious than on lower frequencies, making it more difficult to attain stability.

However, with all these draw-backs, practical experiment has shown that it is possible to build a single-stage amplifier which will give a worth-while amplification without instability. In the experiments conducted by *Wireless World*, it was estimated that a gain of about 10 per stage could be obtained at 7 meters.

The circuit used in these experiments which was found to be most successful is shown in Fig. 1, while the photos show the positions of the parts used in the preselector and the frequency-changer. Short leads are essential and the arrangement shown permits this to be achieved. The horizontal mounting of the tubes enables very short leads to be obtained in the coupling circuits (the tubes are facing each other, because in the English tubes used, the top cap of the preselector is the plate while in the frequency-changer tube it is the control-grid).

Ganged tuning is used and for ease of adjustment the oscillator operates at a lower frequency than the signal frequency. For this reason, the padding condensers C2 and C4 are in the signal-frequency circuits instead of the oscillator.

In the case of the signal-frequency circuits the stray capacities are roughly equalized by adjustment of the tap positions on the coils. It was found that with 40 mmf. tuning condensers, L2 and L3 should be about 0.45 microhenry and coils consisting of 7 turns of No. 12 wire, spaced 8 turns per inch, with a diameter of 3/4-in. are suitable; L2 should be tapped at 4 1/2 turns from the ground end and L3, 3 1/2 turns. The oscillator coil L4 must be about 0.5 microhenry and 8 turns, made as described above, are satisfactory. The coils should be made self-supporting and slight changes in inductance can be made by compressing and spreading turns.

Additional capacity is needed in the oscillator circuit, which is provided by a parallel trimmer of 4 mmf. capacity shunted across C5.

Tests with this preamplifier and frequency-changer with a 2 stage I.F. amplifier were very satisfactory. No difficulties from instability or modulation hum were encountered and the high-frequency amplifier definitely increased the gain sufficiently to justify its use. The additional signal-frequency tuned circuit also greatly reduces the chance of second-channel interference.

The gain in the preselector stage undoubtedly varies with wavelength and is highest at 8 1/2 meters, the maximum wavelength of the set. It falls off somewhat at lower wavelengths but is still appreciable at about 5 1/4 meters.

On wavelengths below 5 meters, it is doubtful if much amplification would be secured; at such wavelengths the input resistance of ordinary glass tubes becomes very low unless tubes of the *Acorn* type are used.

An experimental set using the 955 and 954 tubes should prove very effective and interesting.

# TWO GREAT S-W BOOKS

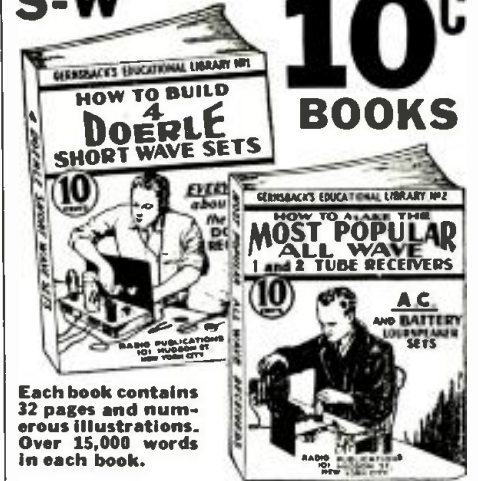

Each book contains 32 pages and numerous illustrations. Over 15,000 words in each book.

### HOW TO MAKE FOUR DOERLE SHORT WAVE SETS

- ★ LITERALLY thousands of radio fans have built the famous DOERLE Short Wave Radio Receivers. So insistent has been the demand for these receivers, as well as instruction details, that this book has been specially published.
- ★ Contains EVERYTHING that has ever been printed on these famous Receivers. These are the famous sets that appeared in the following issues of *SHORT WAVE CRAFT*: "A 2-Tube Receiver that Reaches the 12,500 Mile Mark," by Walter C. Doerle (Dec., 1931-Jan., 1932). "A 3-Tube 'Signal Gripper,'" by Walter C. Doerle (November 1932). "Doerle '2-Tube' Adapted to A. C. Operation" (July 1933). "The Doerle 3-Tube 'Signal-Gripper' Electrified," (August 1933) and "The Doerle Goes 'Band-Spread'" (May, 1934).
- ★ Due to a special arrangement with *SHORT WAVE CRAFT*, we present a complete 32-page book with stiff covers, printed on an extra heavy grade of paper with numerous illustrations. Nothing has been left out. Not only are all the DOERLE sets in this book, but an excellent lower pack if you wish to electrify any of the DOERLE sets. Is also described.

### HOW TO MAKE THE MOST POPULAR ALL-WAVE 1- and 2-TUBE RECEIVERS

- ★ THERE has been a continuous demand right along for a low-priced book for the radio experimenter, radio fan, radio Service Man, etc., who wishes to build 1- and 2-tube all-wave sets powerful enough to operate a loudspeaker.
- ★ This book contains a number of excellent sets, some of which have appeared in past issues of *SHORT WAVE CRAFT*. These sets are not toys but have been carefully engineered. They are not experiments. To mention only a few of the sets the following will give you an idea:
  - The Meekayne 1-Tube Pentode Loudspeaker Set, by Hugo Gernsback.
  - Electrifying The Megadyne.
  - How To Make a 1-Tube Loud-speaker Set, by W. P. Chesney.
  - How To Make a Simple 1-Tube All-Wave Electric Set, by F. W. Harris
  - How To Build A Four-In-Two All-Wave Electric Set, by J. T. Kernsley, and others.
- ★ Not only are all of these sets described in this book, but it contains all of the illustrations, hookups, etc.—And believe it or not, each book contains over 15,000 words of new legible type. Each book is thoroughly modern and up-to-date. All the latest improvements have been incorporated into the sets.
- ★ Remember, these books sell at the extraordinary low price of ten cents; you can not possibly go wrong in buying them. Despite its low cost, our usual guarantee goes with this book as well!
- ★ IF YOU DO NOT THINK THAT THESE BOOKS ARE WORTH THE MONEY ASKED FOR THEM RETURN THEM WITHIN TWENTY-FOUR HOURS AND YOUR MONEY WILL BE INSTANTLY REFUNDED.



There has never been such a wealth of data published in low-priced radio books of this type in the history of the radio publishing business. Take advantage of the special offer we are making and use the coupon below.

**RADIO PUBLICATIONS**  
101 Hudson Street  
New York, N. Y.

RADIO PUBLICATIONS SW-8-36  
101 Hudson Street  
New York, N. Y.

Please send immediately books checked:  
 How to Build Four Doerle Short-Wave Sets.....10c  
 How to Make the Most Popular All-Wave 1- and 2-Tube Receivers.....10c  
 I am enclosing.....c. the price of each book is 10c. (Coin or U.S. Stamps acceptable.) Books are sent post-paid.

Name .....

Address .....

City..... State.....

Please mention *SHORT WAVE CRAFT* when writing advertisers



# New! - GREATEST

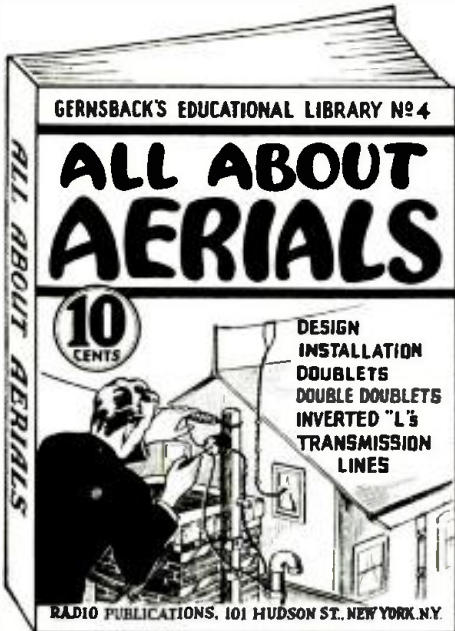

IN recent months the radio public has been made aerial-conscious by virtue of the many articles and advertisements on Aerial Equipment which have appeared in many radio magazines and literature. These articles have been so diversified, and in many cases so conflicting that the radio experimenter, fan and Service Man are beginning to scratch their heads and ask: "What's it all about?" As a consequence, the demand for a low-priced book explaining in a clear, lucid manner the principles underlying the design and installation of efficient aerials has become a crying need. Furthermore, the steadily increasing nuisance of man-made static, resulting in noisy radio reception—particularly in connection with short-wave receivers—has made the importance of a good antenna a paramount issue. For the thousands of radio fans, both short-wave and broadcast, who wish to know just what type of antenna they should use and why, this book has been especially published.

### ALL ABOUT AERIALS

In simple, understandable language this book explains the theory underlying the various types of aerials; the inverted "L," the Doublet, the Double Doublet, etc. It explains how noise-free reception can be obtained, how low-impedance transmission lines work; why transposed leads are used. It goes into detail on the construction of aerials suitable for long-wave broadcast receivers, for short-wave receivers, and for all-wave receivers. The book is profusely illustrated in a manner which will appeal to the most inexperienced in radio; clear, self-explanatory; it is written in so simple a style that it will clear up the aerial situation in your mind, once and for all. Such a wealth of information is presented in this book that you will wonder how it can be done at this low price.

Believe it or not, the book contains over 15,000 words of clear, legible type. It is thoroughly modern and up-to-date.

Remember that this book sells at the extraordinary low price of 10c; you cannot possibly go wrong in buying it. Despite its low cost, our usual guarantee goes with this book.

**IF YOU DO NOT THINK THAT THIS BOOK IS WORTH THE MONEY ASKED FOR IT, RETURN IT WITHIN 24 HOURS AND YOUR MONEY WILL BE INSTANTLY REFUNDED.**

There has never been such a wealth of data published in a low-priced radio book at this price in the history of radio business. Take advantage of this special offer we are making and use the coupon below.

**RADIO PUBLICATIONS**  
101 Hudson Street  
New York, N. Y.

RADIO PUBLICATIONS (No. 4) SW-8-36  
101 Hudson Street  
New York, N. Y.

Please send immediately your book "ALL ABOUT AERIALS," for which I enclose 10c (coin or U. S. stamps, acceptable). Book is to be sent prepaid to me.

Name.....  
Address.....  
City..... State.....

## Short Wave Scouts

(Continued from page 228)

- XEXA—6,120 kc. actually 6,200 kc.—Mexico City, Mexico.
- HP5B—6,030 kc.—"Estacion Radiodifusora Miramar," Panama City, Panama.
- TG2X—5,940 kc.—"La Voz de la Policia Nacional," Guatemala City, Guatemala.
- TRCC—6,550 kc.—"Radioemissora Catolica Costarricense," San Jose, Costa Rica.
- TIPG—6,410 kc.—"La Voz de la Victor," San Jose, Costa Rica.
- HRL-5—11,485 kc.—La Lima Honduras.
- HH—6,814 kc.—"La Voz Del Higuama," San Pedro de Macoris, Dominican Rep.
- HH1A—6,185 kc.—"La Voz del Yaque," Santiago de los Caballeros, Dom. Rep.
- H12J—5,860 kc.—San Pedro de Macoris, Dom. Rep.
- HL—6,500 kc.—Trujillo, Dominican Rep.
- HHX—5,980 kc.—Trujillo, Dominican Rep.
- H1Z—6,310 kc.—"La Voz La Muchasas," Trujillo, Dominican Rep.
- HH2R—9,545 kc.—Port-au-Prince, Haiti.
- HH2S—5,890 kc.—Port-au-Prince, Haiti.
- CEC—10,670 kc.—Santiago de Chile, Chile.
- HCJB—8,770 kc.—"La Voz de la Andes," Quito, Ecuador.
- HC2RL—6,670 kc.—"Hello America" Guayaquil, Ecuador.
- HC2JSH—7,850 kc.—"Radio Ecuador," Guayaquil, Ecuador.
- OAX4D—6,780 kc.—"La Voz de Peru," Lima, Peru.
- OAX1G—6,230 kc.—Lima, Peru.
- VP3MR—7,080 kc.—"The Voice of Guiana," Georgetown, British Guiana.
- YV2RC—5,800 kc.—"Broadcasting Caracas," Caracas, Venezuela.
- YV3RC—6,150 kc.—"Radiodifusora Venezuela," Caracas, Venezuela.
- YV6RV—6,520 kc.—"La Voz de Carabobo," Valencia, Venezuela.
- YV12RM—6,300 kc.—"Emisora 24 De Julio," Maracaibo, Venezuela.
- HJ2ABF—6,115 kc.—"La Voz de Labs Fuentes," Cartagena, Colombia.
- H12ABD—5,980 kc.—"Radio Bucaramanga," Bucaramanga, Colombia.
- HJ2ABC—5,970 kc.—"La Voz de Cucuta," Cucuta, Col.
- HJ3ABH—6,012 kc.—"La Voz de la Victor" Bogota, Colombia.
- HJ4ABA—11,810 kc.—"Ecos de la Montana," Medellin, Colombia.
- HJ4ABC—6,451 kc.—"Ecos del Combeima," Ibaguete Colombia.
- HJ4AB—6,080 kc.—"La Voz de Pereira," Pereira, Colombia.
- HJ5ABC—6,150 kc.—"La Voz de Colombia," Cali, Colombia.
- SUV—10,055 kc.—Cairo, Egypt.
- ZSS—18,890 kc.—Capetown Union S. Africa.
- OPL—20,040 kc.—Leopoldville, Belgium Congo.
- HAT-4—9,125 kc.—"Radio Budapest Labs," Budapest, Hungary.
- TFJ—12,240 kc.—Reykjavik, Iceland.
- RNE—12,000 kc.—Moscow, U.S.S.R.
- TPA-2—15,240 kc.—"Radio Colonial," Pontoise France.
- TPA-3—11,880 kc.—"Radio Colonial," Pontoise, France.
- TTA-1—11,710 kc.—"Radio Colonial," Pontoise, France.
- EAQ—9,860 kc.—"The Voice of Spain," Madrid, Spain.
- EHY—10,070 kc.—Madrid, Spain.
- PHI—11,730 kc.—Huizen, Netherlands.
- HRJ—14,535 kc.—"Radio Nations," Geneva, Switzerland.
- HRO—11,385 kc.—"Radio Nations," Geneva, Switzerland.
- HBI—9,595 kc.—"Radio Nations," Geneva, Switzerland.
- HRP—7,797 kc.—"Radio Nations," Geneva, Switzerland.
- 2RO-3—9,635 kc.—"Radio Roma," Rome, Italy.
- 2RO-4—11,810 kc.—"Radio Roma," Rome Italy.
- 2RO-1—6,084 kc.—"Radio Roma," Rome, Italy.
- HVJ—15,110 kc.—"Radio Vatican," Vatican City, Italy.
- DJA—9,560 kc.—Berlin, Germany.
- DJB—15,200 kc.—Berlin, Germany.
- DJC—6,020 kc.—Berlin, Germany.
- DJD—11,770 kc.—Berlin, Germany.
- DJE—17,760 kc.—Berlin, Germany.
- DJI (Now DZA)—9,675 kc.—Berlin, Germany.
- DJJ (DZB)—10,042 kc.—Berlin, Germany.
- DJM—6,079 kc.—Berlin, Germany.
- DJK—15,280 kc.—Berlin, Germany.
- VK2ME—9,590 kc.—"The Voice of Australia," Sidney, Australia.
- VK3ME—9,510 kc.—Melbourne, Australia.
- VK3LR—9,580 kc.—Melbourne, Australia.
- HB—10,535 kc.—Taiwan, Formosa.
- D'N—9,540 kc.—Berlin, Germany.
- DIQ (Now DZC)—10,290 kc.—Zwessen, Germany.

SAMUEL SOLITO,  
303 Beaver St.,  
Leetsdale, Pa.

# New! - 10c BOOKS

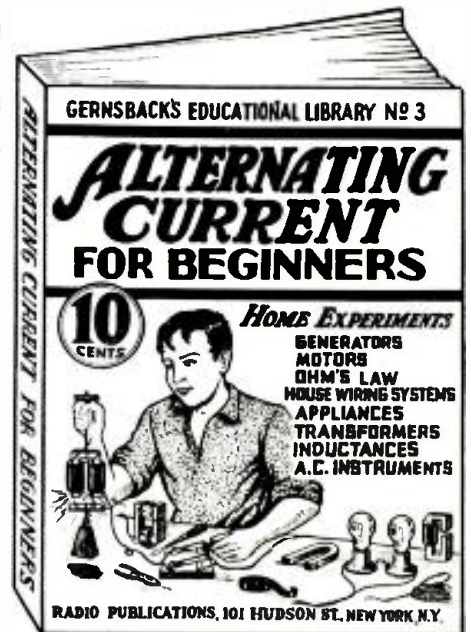

LITERALLY thousands of beginners each year ask the question "HOW CAN I GET STARTED IN RADIO?" In order to understand the theory of radio, it is necessary, first of all, to have a fundamental knowledge of electricity and, particularly of alternating currents. We stress this point because radio is a study of alternating currents of a very high frequency nature.

In this book, which is prepared especially for new beginners, we explain in a simple, lucid manner: How Alternating Current is Generated; What Its Properties Are; What The Laws Governing It Are, and How It is Applied To Everyday Household Use. Furthermore, we give in simple language detailed instructions on how to perform practical experiments with alternating current in the home.

### ALTERNATING CURRENT FOR BEGINNERS

This book contains everything necessary to give the beginner his first foothold in the study of electricity and Radio. Electric circuits are explained with simple analogies to hydraulic systems. Ohm's Law, one of the fundamental laws of radio, is thoroughly explained; the generation of alternating current; sine waves; the units—volts, amperes, and watts are explained. Condensers, transformers, A.C. instruments, motors and generators—all these are thoroughly discussed. House-wiring systems, electrical appliances and electric lamps—nothing has been left out.

Here are some of the practical experiments which you can perform at home. Simple tests for differentiating between alternating and direct current; how to light a lamp by induction; how to make a simple electric horn; how to demagnetize a watch; how to test motor armatures; how to charge storage batteries from A.C. outlet; how to test condensers with A.C.; how to make A.C. electro magnets; how to fry eggs on a cake of ice; how to make simple A.C. motors and many others.

The book contains 32 pages, profusely illustrated with clear, self-explanatory diagrams. It contains over 15,000 words of clear, legible type. It is an education in itself and lays the groundwork for a complete study of radio and electricity.

At the extraordinary price of 10c, you cannot possibly go wrong. Despite its low cost, however, our usual guarantee goes with this book.

**IF YOU DO NOT THINK THAT THIS BOOK IS WORTH THE MONEY ASKED FOR IT, RETURN IT WITHIN 24 HOURS AND YOUR MONEY WILL BE INSTANTLY REFUNDED.**

There never has been such a wealth of data published in a low-priced radio book of this type in the history of the radio publication business. Take advantage of this special offer we are making and use the coupon below.

**RADIO PUBLICATIONS**  
101 Hudson Street  
New York, N. Y.

RADIO PUBLICATIONS (No. 3) SW-8-36  
101 Hudson Street  
New York, N. Y.

Please send immediately your book "ALTERNATING CURRENT FOR THE BEGINNER," for which I enclose 10c (coin or U. S. stamps acceptable). Book is to be sent prepaid to me.

Name.....  
Address.....  
City..... State.....

Please mention SHORT WAVE CRAFT when writing advertisers

# Cut Prices on Many Popular Radio Books

**IMPORTANT—All prices have been drastically reduced—many new books included!**

We herewith present a selected collection of recent important radio books. We have, after an exhaustive study, selected these volumes because they represent the foremost radio books of their kind in print today. There is such a great variety that we are sure it will satisfy any taste as well as any requirement that the student of radio might have.

We publish no catalog and ask you to be kind enough to order direct from this page. Prompt shipments will be made to you direct from the publishers. We merely act as a clearing house for a number of radio publishers and **OUR PRICES ARE AS LOW OR LOWER THAN WILL BE FOUND ANYWHERE.** Remit by money order or certified check. Register all letters containing cash.

**AUDEL'S RADIOMAN'S GUIDE.** by Frank B. Graham. Cloth covers (flexible), size 5x6 1/2", 220 pages, 200 illustrations. Price..... **\$.89**

A practical, concise book presenting the theoretical and practical information for the proper operation, maintenance and service as applied to modern radio practice.

**EXPERIMENTAL RADIO,** by R. R. Hansey, Prof. of Physics, Indiana University. Cloth covers, size 7 1/2 x 5 1/2", 256 pages, 168 illustrations. Price..... **\$2.69**

A marvelous book for the experimenter. Experiments galore in easy comprehensive language.

**MODERN RADIO SERVICING** (2nd Revised and Greatly Enlarged Edition of Radio Servicing Course) by Alfred A. Ghirard. Cloth covers, size 8x6", 1300 pages, over 700 illustrations. Price..... **\$4.00**

One of the greatest text books on radio servicing. Contains hundreds of facts on up-to-date servicing methods—construction and operation of latest test equipment, auto radios, all-wave receivers, etc.

**DRAKE'S CYCLOPEDIA OF RADIO AND ELECTRONICS,** by H. P. Mandy. Cloth covers, size 6x9". 1650 pages, 1030 illustrations. 1932 Edition. Price..... **\$4.88**

The largest work of its kind ever put between two covers. New and up-to-date; a standby for every radio man.

**FUNDAMENTALS OF RADIO,** by R. R. Hansey, Professor of Physics, Indiana University. Cloth covers, size 9 1/2 x 6", 372 pages, illustrated. Price prepaid..... **\$3.46**

The backbone of the radio art. This book gives you the foundation on radio from A to Z.

**ELECTRICITY AT HIGH PRESSURES AND FREQUENCIES,** by Henry L. Transom. Paper covers, size 7 1/2 x 5 1/2", 218 pages, 111 illustrations. Price Prepaid..... **\$1.89**

A marvelous book for the student in electricity and radio. General fundamentals lead up to a complete discussion of every type of Tesla and Oudin high-frequency coils, Gelsler tubes, etc.; construction details of Tesla coils are given in great profusion. **THE ONLY BOOK OF ITS KIND.**

**RADIO CONSTRUCTION AND REPAIRING,** by James A. Moyer and John F. Westral. Cloth covers, size 8x5". Well illustrated, new revised fourth edition, containing 411 pages, still remaining **\$2.50** at the same price.

A handbook that every radio set tester and general student must have. The diagrams alone are worth the price of the book.

**THEORY OF VACUUM TUBE CIRCUITS,** by Leo James Peters. Cloth covers, size 6x9". 226 illustrations, 226 pages. Price..... **\$2.98**

It is one thing to "connect green lead No. 1 to pink lead No. 4," but it is another to know why the connections are made. Read this book and learn the design factors in tube circuits.

**HOW TO PASS U. S. GOVERNMENT RADIO LICENSE EXAMINATIONS,** by R. L. Duncan and C. E. Drew. Flexible covers, size 9 1/2 by 7". 170 pages, 92 illustrations, appendix. Price..... **\$1.89**

The most important book on the subject ever published. Gives every conceivable angle which will help you to pass a radio license examination successfully.

**THE RADIO MANUAL,** by George K. Sterling and Robert S. Kruse. Elk. 2nd enlarged edition. Flexible fabricoid covers. Size 5 3/4 x 8", 805 pages, 348 illustrations. Price..... **\$5.88**

A complete Radio Course for the operator, the technician, the amateur, the student and experimenter. Everything imaginable in the whole radio art is covered in this great book—the "radio Bible" of the amateur. **DON'T MISS THIS.**

**OFFICIAL RADIO SERVICE MANUAL, Volume 1,** by Hugo Gerushack and C. Walter Palmer. Flexible, looseleaf leatherette cover, size 9x12", over 2,000 illustrations, over 100 pages. Price 1 prepaid..... **\$3.00**

Whether for public address work, receiver diagrams or tube data, every conceivable kind of radio set information needed will be found in this great service manual.

**OFFICIAL RADIO SERVICE MANUAL, Volume 5,** by Hugo Gerushack and C. Walter Palmer. Flexible, looseleaf leatherette cover, size 9x12", over 3,000 illustrations, over 1,000 pages. Printed on thin Bible paper. Price prepaid..... **\$5.86**

This 1935 Manual is the most authentic and elaborate service guide ever used in the radio field. There has never appeared such a complete radio manual as this one.

**PRINCIPLES OF RADIO COMMUNICATION,** by J. H. Morecroft, Prof. of Electrical Engineering, Columbia University. Cloth covers, size 9 1/2 x 6", 388 pages, profusely illustrated. Price..... **\$7.35**

The radio classic, by the dean of radio. Covers entire radio art as does no other book.

**RADIO ENGINEERING,** by Frederick Emmott Terman. Cloth covers, size 6x9", 700 pages, 425 illustrations. Price..... **\$4.88**

Not a book for the beginner in radio, but a reference volume for the technician who wants modern information on the design and use of band-selectors, automatic volume control, diode detectors, and the thousand-and-one units and circuit arrangements which have been recently developed.

## HOW TO ORDER

We cannot ship C.O.D. Our prices are net, as shown. Some of the books sent prepaid (in U. S. only). Those that are not thus listed will be shipped by express collect if sufficient postage is not included by you.

**EXPERIMENTAL RADIO ENGINEERING,** by John H. Morecroft. Cloth covers, size 6x9", 316 pages, 250 illustrations. Price..... **\$3.46**

A student's book; devoted to the principles of radio apparatus; intended to accompany a course in electricity. The best of its kind.

**RADIO OPERATING QUESTIONS AND ANSWERS,** (Revised Fifth Edition), by Nilson and Horning. Cloth covers, size 5 1/2 x 8". 390 pages, 96 illustrations. Price..... **\$2.47**

Contains over 600 questions and answers covering all phases of licensed radio operation. Revised to contain much new material. Nothing better in print.

**5 METER RADIOTELEPHONY,** by Frank Jones, 52 pages, 89 illus. Per copy, postpaid..... **\$.25**

Here you learn to construct a variety of 5 meter transmitters and antennas. Written by the designer of the 5 meter equipment for the San Francisco Bay Bridge.

## RADIO PUBLICATIONS, 97 HUDSON ST., NEW YORK, N. Y.

### A. F. Amplifier for 1 Million Cycles!

(Continued from page 219)

to be applied (to avoid an attenuation too large in the range towards the lower audio frequencies) the unwanted total circuit capacity of the amplifier stage shown in Fig. 1 amounts to 10 mmf. only.

It might be of interest to mention that the internal capacity of the tube applied was 17.5 mmf. which brought the total capacity of the complete stage up to 27.5 mmf. Since there are many possibilities to design suitable tubes with a total internal capacity much lower than that of the one used, much better results in the future are to be expected.

This low capacity made it possible (in connection with some simple correction methods) to obtain an almost uniform amplification, starting with an A.F. frequency of 0.2 cycle up to 1,000,000 cycles! In addition to these remarkable qualities, an overall amplification factor was obtained which is not unreasonable, small as Fig. 3 indicates.

The designer of the amplifier, Manfred von Ardenne, used as a means of partial correction small chokes (see Fig. 1 and Fig. 2) and also a capacitive bridging of the cathode resistance. Since the later method is of great convenience, it will probably be used very frequently in future design.

In case the correction method by means of by-pass condensers is to be used, attention should be paid to the fact that the time constant of the "cathode correction circuit" must be about equal to the one of the plate circuit. (see Fig. 4). This demand requires of course a little bit of experimentation if heavy mathematical exercises are to be avoided, but for all amateurs well acquainted with AVC circuits and especially with delayed AVC (in which the time constant is of great importance), will be able to solve this problem.

Another important fact about this new

type of amplifiers is, according to Mr. von Ardenne, the problem of a suitable power supply. Since it is impossible to keep down the internal resistance of a common power supply by means of by-pass condensers, because the capacities needed would be of an inconvenient value, another method has been utilized to avoid trouble.

Mr. von Ardenne did the trick by means of the so-called glow-discharge potentiometer (a neon glow lamp, but the space between cathode and plate is tapped by means of suitable electrodes). Two of these neon potentiometers, each having an internal resistance of about 200 ohms, are connected with a rectifier tube which in turn is connected with the power transformer. The practise has shown that this method of solving the power-supply problem is very efficient, even in case an especially high amplifier stability is required.

### A 55 Tube All-Wave Set

(Continued from page 215)

stages required eleven more tubes, making a total of fifty-five tubes for the "entire ensemble."

The operation of this set, after many months of labor and research was brought to absolute stability and phenomenal sensitivity. The most interesting practical development was the resulting clarity of reception of extreme short-waves, 5 to 10 meters. The absolute stability of the oscillator regardless of the line voltage fluctuation and regardless of the amplitude of the received signal, was a revelation—both in the necessity of a stable receiver as well as the necessity of a stable transmitter. Many oscillator circuits were found to vary with the amplitude of the received signal as

much as 15 kilocycles at 5 meters, due to fluctuations in the "B" supply, as the received signal attempts to build up. This increased signal, causing a change in the current drain of the "B" supply, results in a change in the voltage impressed on the oscillator. The resulting changes in the internal characteristics of the oscillator tube causes frequency shift which detunes the signal, frequently resulting in fluttering or motor-boating. All of this was eliminated on the final form of this gigantic receiver.

The other practical resulting development was the proof that transmitters themselves fluctuate in a similar manner causing a very wide swing in frequency much more than is tolerable in the non-regenerative type of receiver.

Regenerative or super-regenerative receivers easily accept such a wide band as is covered by a "wobbling" transmitter, but they also accept adjacent interference and therefore are undesirable. Certain signals which were almost unreceivable on super-regenerative sets, due to their faintness, were easily receivable on this truly custom-built radio set, because of their stable frequency, whereas other signals much stronger—but having greater "wobulation" were unsatisfactory. No doubt, the 5 meter transmitters will improve in this respect as time goes on, and then we will have really satisfactory reception on these bands.

It is probable that this set will never be duplicated on account of the enormous expense involved.

### 6-Tube A. C. Super-Het Covers Three Bands

(Continued from page 217)

in conjunction with the latest type oscillographs and other apparatus, so that a very smooth and reliable performance is obtained with the D-8 receiver.

This article has been prepared from data supplied by the courtesy of Wholesale Radio Service Co.

Please mention SHORT WAVE CRAFT when writing advertisers

## New "Spiderweb" All-Wave Aerial

(Continued from page 215)

the doublets have been carefully chosen for the best utilization of the space and so that the overlapping of two adjacent dipoles will hold up the intermediate frequencies between bands, thus giving practically uniformly high performance over the entire range (5 to 70 megacycles) covered by the dipole antenna.

When receiving signals in the range of 140 to 5000 kilocycles, the whole network functions as a single unit.

The main Spiderweb Kit, as furnished, includes the three dipoles "A-B," "C-D" and "E-F" completely assembled as shown in Figure 3, ready to be unwound and erected as shown by the solid lines in Figure 1. It will effectively pass signals in the frequency range of 140 to 23,000 kilocycles. The two doublets, "G-H" equipped with loading coils and "K-L," shown dotted in Figure 1, are furnished complete ready to assemble to the main network in the RCA Spiderweb Accessory Kit. With this pair of dipoles attached to the main network full coverage is obtained, 140 to 70,000 kilocycles. Connections of the accessory kit are shown in Figure 5.

A feature of importance incorporated in this design is superior noise reduction on those bands affected mostly by man-made interference, namely the "C" and "D" bands (6,000 to 70,000 kilocycles). Within these bands the intercepted signals are usually quite weak and man-made interference is generally the strongest and most localized. The noise reduction is obtained by erecting the Spiderweb Multiple Dipole Antenna remotely to the source of greatest interference and coupling it to the receiver through a balanced non-pick-up transmission line. The transmission line has been carefully chosen, as in our previous designs. Seventy-five feet of line is assembled to the network. In case additional line is required, 45-foot units are available, which may be added. These units must not be cut, as the line terminates at the receiver in a carefully designed transformer which is matched to the line impedance.

### Receiver Coupling Transformer

The receiver coupling transformer in outward appearance is almost identical to the one used in the De Luxe World-Wide Antenna System. Internally it is quite different. In this design the primary (line winding) consists of two interwound sections ("A" and "B" Figure 4), thus giving a perfect balance when coupled to the line. Better efficiency with superior shielding against any capacity pickup whatsoever is obtained in this new design. It is very important to note that the noise-elimination feature of the system depends largely on the design of the transformer. The purpose of this transformer is to eliminate interference signals that come down each side of the transmission line in phase, and to pass on to the receiver the "Out of Phase" entertainment signals from the dipoles. Refer to Figure 4 and assume that the same voltage is set up in each branch of the transmission line, as is always the case when any signal whatsoever is picked up directly by the line. This voltage will cause current to pass down both sides of the line through coils "A" and "B" to grounded shield "S" by capacity coupling.

Note that the flux of coil "A" cancels that of coil "B," since the voltage applied to the two ends of coils "A" and "B" from the transmission line are in phase. These coils are interwound so as to make this cancellation more nearly complete. Since the resultant flux is zero, there can be no voltages set up in the secondary winding coil "C" by induction. Any possibility of voltage being induced in coil "C," due to capacity coupling, is eliminated by the electrostatic shield "S."

### Signal Voltage Not Cancelled

Signal frequencies from 5 to 70 megacycles are picked up by the various dipoles and fed to the transmission line out of

phase as the branches of the dipoles are one-quarter wavelength long. In other words, a signal within these limits of frequency will produce at any given instant a positive voltage in one of the branches of a doublet and, at the same instant, produce a negative voltage in the other branch to flow down one side and up the other. Coils "A" and "B" are aiding for these currents, and the total flux of these coils induces a voltage in the secondary winding coil "C" which is connected to the input terminals of the receiver through series condenser "E."

Signals of lower frequencies than about 5 megacycles are impressed on the antenna network as a whole and follow down the transmission line in phase. They pass through windings "A," "B" and "D" and appear across condenser "F" and feed to the input of the receiver through the series winding "C."

The space available for erecting an antenna in the open is usually restricted in densely populated areas. This is particularly true in regards to the antenna length. It is relatively easy to design an antenna of reduced size to meet this condition, but to obtain high signal pickup efficiency along with reduced size is not so easy. This problem is solved by the Spiderweb Antenna System, which employs three small resonant dipoles in the "C" band and two in the "D" band. These dipoles form the spiderweb network shown in Figure 1, previously described in detail. This antenna is small in size, having a span of only 37 feet and a height of approximately 11 feet. Even though it is unusually small in size, it has exceptionally high pickup. The whole network requires supports only at its extremities the same as the simplest "L" or "T" type antenna.

**Great Mechanical Strength:** The new kit is also designed to obtain the greatest possible mechanical strength with a minimum of material. The three main supporting dipoles run the full span, terminating in a specially designed "spreader." The spreader is also an equalizing lever that properly distributes the load to the various wires.

The time required to erect an RCA Spiderweb Antenna has been reduced to a minimum, as all the wire lengths are carefully measured and soldered in place at the factory. Wires that are to be connected to the spreaders are terminated with a soldered loop at the proper length. Specially designed hooks, very easy to install, are furnished for making these connections. The main network is carefully packed so that it can be readily laid out as shown in Figure 3, after which each of the coils is unwound, as shown by the dotted lines, and fastened to their respective places, as shown in Figure 1.

It is the belief of the designers that this new "All Wave" antenna is the first to be offered to the public that combines all the objectives set forth.

This article has been prepared from data supplied by courtesy of RCA Mfg. Co. (J. E. Albright, RCA Engineering Dept.)

## HAMS AND FANS

Both will find interesting and important articles in the September issue. For example:

**A brand-new TRANSMITTER—using 6L6 type tubes. Vital to every "HAM"—By George W. Shuart, W2AMN.**

**Double Super-het—Something Entirely New! Uses two different I.F. frequencies—"High Gain" on all wavelengths. By M. Harvey Gernsback.**

**A "METAL" Tube Transmitter that uses all "Receiver" parts. By Alvin Abrams.**

**Also other Receiver articles of interest to S-W "FANS."**

Please mention SHORT WAVE CRAFT when writing advertisers

## NEW Extension Auto Speaker



MODEL 930

for Camping, Touring, etc.

- 8" Nokoil Speaker gives electro dynamic performance yet draws no current from battery.
- Cabinet easily taken apart to make proper connections to the universal transformer which matches all tubes.
- Any service man can easily and inexpensively furnish proper length cord and plug-in connection for automatically disconnecting car speaker and connecting extension speaker.

Here is a big Summer Item

Our special low price enables you to make it a great leader. List \$9.30

Write for further particulars, complete catalog and name of your nearest distributor.

**WRIGHT-DECOSTER, Inc.**

2257 University Ave., St. Paul, Minnesota  
Export Dept.: M. Simons & Son Co., New York  
Cable Address: "Simontride,"  
Canadian Office:  
Wright-Decoster, Inc., Guelph, Ontario

## Westinghouse Power Generator

Manufactured for U. S. Signal Corps  
200 Watt 110 V. AC

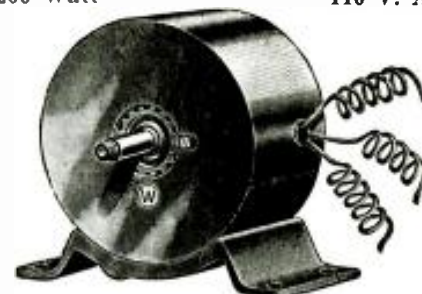

## A. C. ELECTRICAL POWER

from a Windmill, from available Waterpower, from your Automobile, from your Motorcycle, from your Bicycle, Foot-pedals or Handcrank; operates A.C. Radio Sets in D.C. districts, also A.C. Radio sets from 32 V. D.C. faria light systems; use two generators in series to set 200 V. A.C. Used as an A.C. Dynamo, lights ten 20 Watt 110 Volt lamps; Short Wave Transmitter supplying 110 Volts A.C. for operating "Ham" Sets; Motor Generator; Public Address Systems; Camp lighting; etc., etc.

There Are Over 25 Applications

### SPECIFICATIONS:

**HOUSING**—Aluminum (Diameter 6 1/2 in., Length—5 1/4 in.). **SHAFT**—2 3/16 in. (driving end), Diameter—9/16 in. (the end is threaded for a distance of 3/4 in.). **BASE**—Cast Iron (Length—7 1/2 in., Height 1 9/16 in., Width 4 1/2 in.). **OUTPUT**—200 Watt 110 volts AC (speed 4500 R.P.M.). **STATORS**—Two pairs (two North and two South). **ROTOR**—12 tooth inductor. Built-in commutator. Rotor turns in ballbearings.

3/4 to 1 1/2 H.P. needed to run Generator.

**BLUE-PRINT 22 x 28 in. and Four-Page 8 1/2 x 12 in. Applications and INSTRUCTION SHEETS FREE with Generator.**

Generator, as described, including four replacement carbon brushes, Blue-print and instructions **\$7.90**

Send \$2.00 deposit balance C.O.D. Shipping weight 18 lbs.

(Replacement carbon brushes bought separate \$1.50 per set of four. Set of instructions bought separate \$1.00.)

**WELLWORTH TRADING COMPANY**  
560 West Washington Blvd., Dept. SWC-836, Chicago, Illinois

# ••• SHORT WAVE ESSENTIALS FOR MEMBERS OF THE SHORT WAVE LEAGUE •••

## Application for Membership SHORT WAVE LEAGUE

SHORT WAVE LEAGUE 8-36  
99-101 Hudson Street, New York, N. Y.

I, the undersigned, herewith desire to apply for membership in the SHORT WAVE LEAGUE. In joining the LEAGUE I understand that I am not assessed for membership and that there are no dues and no fee of any kind. I pledge myself to abide by all the rules and regulations of the SHORT WAVE LEAGUE, which rules you are to send to me on receipt of this application. I consider myself belonging to the following class (put an X in correct space): Short Wave Experimenter  Short Wave Fan  Radio Engineer  Student  I own the following radio equipment:

Transmitting .....

Call Letters.....

Receiving .....

Name .....

Address .....

City and State.....

Country .....

I enclose 10c for postage and handling for my Membership Certificate.

### SHORT WAVE LEAGUE LETTERHEADS

A beautiful letterhead has been designed for members' correspondence. It is the official letterhead for all members. The letterhead is invaluable when it becomes necessary to deal with the radio industry, mail order houses, radio manufacturers, and the like; as many houses have offered to give members who write on the LEAGUE'S letterhead a preferential discount. The letterhead is also absolutely essential when writing for verification to radio stations either here or abroad. It automatically gives you a professional standing.

A—SHORT WAVE LEAGUE letterheads, per 100..... **50c**

### OFFICIAL SHORT WAVE LISTENER MAGAZINE

The finest magazine of its kind ever published—totally different in get-up and contents from any other. Contains the largest listing of short wave stations in the world, up-to-the-minute, including "Police," "Television" and short-wave stations, as well as a special list of the star short-wave stations with their frequencies and call letters. Also contains photos and descriptions of short-wave broadcasting stations in various parts of the world with photos of short wave studio artists—How to locate "weak" distance stations, and other hints for the "short-wave listener"—Question and Answer Department for the "listener"—Silver Cup Trophy for best photo of readers' listening "Posts," etc.

B—Official Short Wave Listener Magazine.....Prepaid **15c**

### RADIO MAP OF THE WORLD AND STATION FINDER

The finest device of its kind published. The world's map on heavy board is divided into 23 sections, while the rotary disc shows you immediately the exact time in any foreign country. Invaluable in logging foreign stations. Also gives call letters assigned to all nations. Size 11"x22".

C—Radio Map of the World and Station Finder.....Prepaid **25c**

### GLOBE OF THE WORLD

This highly important essential is an ornament for every den or study. It is a globe, 6 in. in diameter, printed in fifteen colors, glazed in such a way that it can be washed. This globe helps you to intelligently log your foreign stations. The base is of solid walnut, and the semi-meridian of a nickel-like metal. Entire device substantially made, and will give an attractive appearance to every station, emphasizing the long-distance work of the operator.

D—Globe of the World.....Prepaid **89c**

### SHORT WAVE LEAGUE LAPEL BUTTON

This beautiful button is made in hard enamel in four colors, red, white, blue and gold. It measures three quarters of an inch in diameter. By wearing this button, other members will recognize you and it will give you a professional air. Made in bronze, gold filled, *not plated*. Must be seen to be appreciated.

E—SHORT WAVE LEAGUE lapel button.....Prepaid **35c**

EE—SHORT WAVE LEAGUE lapel button, like the one described above but in solid gold.....Prepaid **\$2.00**

### SHORT WAVE LEAGUE SEALS

These seals or stickers are executed in three colors and measure 1 1/4 in. in diameter, and are gummed on one side. They are used by members to affix to stationery, letterheads, envelopes, postal cards and the like. The seal signifies that you are a member of the SHORT WAVE LEAGUE. Sold in 25 lots or multiples only.

G—SHORT WAVE LEAGUE seals.....per 25, Prepaid **15c**

### SHORT WAVE MAP OF THE WORLD

This beautiful map, measuring 18x26 in. and printed in 18 colors is indispensable when hung in sight or placed "under the glass" on the table or wall of the short wave enthusiast. It contains a wealth of information such as distances to all parts of the world, political nature of the country in which a broadcast station is located, etc., and from the manner in which the map is blocked off gives the time in different parts of the world at a glance.

F—SHORT WAVE Map of the World.....Prepaid **25c**

**PLEASE NOTE THAT ABOVE ESSENTIALS ARE SOLD ONLY TO MEMBERS OF THE LEAGUE—NOT TO NON-MEMBERS WITH EXCEPTION OF ITEM B.**

Send all orders for short wave essentials to SHORT WAVE LEAGUE, 99-101 Hudson Street, New York City.

If you do not wish to mutilate the magazine, you may copy either or both coupons on a sheet of paper.

SHORT WAVE LEAGUE 99-101 Hudson St., New York, N. Y.

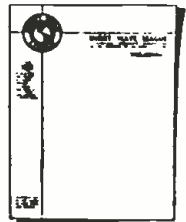

A—50c per 100



B—15c per copy



C—25c each



D—89c each



E—35c each

### A FEW WORDS AS TO THE PURPOSE OF THE LEAGUE

The SHORT WAVE LEAGUE was founded in 1930. Honorary Directors are as follows: Dr. Lee de Forest, John L. Reintz, D. E. Replogle, Hollis Baird, E. T. Somerset, Baron Manfred von Ardenne, Hugo Gernsbach, Executive Secretary.

The SHORT WAVE LEAGUE is a scientific membership organization for the promotion of the short wave art. There are no dues, no fees, no initiations, in connection with the LEAGUE. No one makes any money from it; no one derives any salary. The only income which the LEAGUE has is from its short wave essentials. A pamphlet setting forth the LEAGUE'S numerous aspirations and purposes will be sent to anyone on receipt of a 3c stamp to cover postage.

### FREE MEMBERSHIP CERTIFICATE

As soon as you are enrolled as a member, a beautiful certificate with the LEAGUE'S seal will be sent to you, providing 10c in stamps or coin is sent for mailing charges.

Members are entitled to preferential discounts when buying radio merchandise from numerous firms who have agreed to allow lower prices to all SHORT WAVE LEAGUE members.

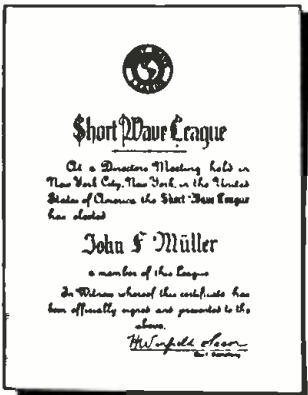

If you wish your name engraved on the Free Membership Certificate, as illustrated above, please send 25c to cover cost.

### SHORT WAVE ESSENTIALS LISTED HERE SOLD ONLY TO SHORT WAVE LEAGUE MEMBERS

They cannot be bought by anyone unless he has already enrolled as one of the members of the SHORT WAVE LEAGUE or signs the blank on this page (which automatically enrolls him as a member, always provided that he is a short wave experimenter, a short wave fan, radio engineer, radio student, etc.).

Inasmuch as the LEAGUE is international, it makes no difference whether you are a citizen of the United States or any other country. The LEAGUE is open to all.



G—15c for 25

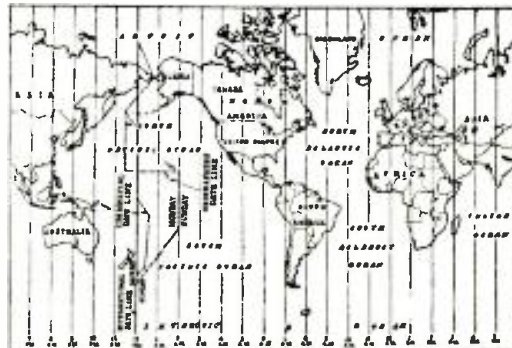

F—25c each

SHORT WAVE LEAGUE, 99-101 Hudson Street, New York, N. Y.

Gentlemen:

I am already an enrolled member in the SHORT WAVE LEAGUE

I am a new member and attach my application to this coupon

Please send me the following short wave essentials as listed in this advertisement:

.....  
.....  
.....

for which I enclose \$ ..... herewith.

(The LEAGUE accepts money order, cash or 50¢ U. S. Stamps in any denomination. Register each and stamp.)

Name .....

Address .....

City and State .....

Country .....

Please mention SHORT WAVE CRAFT when writing advertisers

**Scott 40-Tube Receiver**

● A 40-tube radio, the world's largest, has been completed by E. H. Scott, famous Chicago radio engineer, after years of study and development in the Scott laboratories.

The "Quaranta" (Spanish for "forty") receives programs from every continent on the globe, with tremendous volume.

Where the listener in North America wants satisfactory reception from foreign or distant domestic stations, noise has been a problem of first importance. While in tropical climates, static is so invariably bad that the listener has been forced usually to confine his entertainment to the short waves because of their greater signal strength for the transmission power used.

The "Quaranta" has a revolutionary double automatic volume control, which allows the R.F. tube to operate at maximum efficiency, thereby cutting noise to such a minimum that the receiver achieves the highest known signal-to-noise ratio with unmodulated carrier. The solving of this problem made it practical to incorporate a sensitivity so great that the receiver will



The Latest!—A 40-Tube All-Wave Receiver!

pick up from every corner of the world signals of less than 1,000,000th part of a volt. In addition, the sensitivity is continuously variable.

The Scott engineers developed a panel controlled selectivity which is continuously variable from 2 to 16 K.C. and which separates stations allocated but 10 K.C. apart even where their field strength at the listening post varies as much as 5000 to 1.

The complete tonal range is amplified through five speakers, operating on three separate audio channels: the first reproducing the bass frequencies from 30 to 125 cycles, by means of a bass frequency band pass filter, which amplifies all bass frequencies rather than just one; the middle having a flat frequency range from 100 to 6,000 cycles; and the third embodying the same principles reproducing the high frequencies from 3,000 to 16,000 cycles. True tone control is at the disposal of the listener by means of separate Bass and Treble panel controls.

Still not content to rest on these laurels, the designers of this new set eliminated still another reception shortcoming. The usual amplifier power output of less than 15 watts is unable to handle peak passages in concert or popular music. Loud strong passages distort or go "haywire" when the full transmitted volume is put through the speaker. The power output of the "Quaranta" was raised to 100 watts, so that all the volume transmitted is handled without any distortion detectable to the human ear, even when the volume is turned up to a point where the set can be heard a mile away.

# CLASSIFIED

Advertisements are inserted at 5c per word to strictly amateurs, or 10c a word to manufacturers or dealers. Each word in a name and address is counted. Cash should accompany all orders. Copy for the September issue should reach us not later than July 6.

<p><b>GENERATORS</b></p>	<p>ance, Power, Wire Sizes, etc. Range: 1 micro-amp. to 1000 amps.; 1 micro-volt to 10,000 volts; 1 micro-ohm to 10 meg-ohms; 1 micro-watt to 10 megawatts; wire sizes 0 to 36 B. &amp; S. gauge. Introductory price \$1.00 prepaid. The Dataprint Co., Box 322, Ramsey, N.J.</p>	<p><b>SHORT WAVE COMPONENTS</b></p>
<p><b>TURN SCRAP INTO MONEY.</b> Autopower shows you how easily and economically auto generators can be converted into A.C. or D.C. generators and D.C. motors, 2 to 1000 volts; for sound, radio, power, light, or welding. No previous experience necessary—complete information all in new book, with simple instructions and illustrations. Endorsed by thousands. Only \$1.00 postpaid. Autopower, Inc., 414 S. Hoyne Ave., Chicago.</p>	<p><b>BARGAINS: NO. 227 TUBES.</b> Nationally known make, guaranteed fit for \$1.00. Other numbers at low prices. Write numbers you are interested in and how many. Gold Shield Products Co., 17 West 60th St., New York.</p>	<p><b>4 BAKELITE PLUG-IN COILS.</b> wound on tube bases .30, tall forms .40, six prong .60. Noel, 728 Birch, Scranton, Pa.</p>
<p><b>"HAM" OFFERS AND WANTS</b></p>	<p><b>QSL—CARDS—SWL</b></p>	<p><b>SHORT WAVE RECEIVERS</b></p>
<p><b>SELL EIGHT TUBE ALL-WAVE</b> Midwest superheterodyne. Skywider tuned radio frequency. Large Power Amplifier, Bernard Signal Generator, High power Microphone, Small Hard Press, Want large allwave receiver, Glenn Wall, Chanute, Kans.</p>	<p><b>BACK IN BUSINESS! QSL'S! SWL'S!</b> New Equipment, New Ideas, Snappy! Bright! Different! 200 two colors \$1.00. Made in order. Samples, Service, W.S.A.R. Tupelo, Miss.</p>	<p><b>CRYSTAT SET—2100 MILE RECOR.</b> Blueprint 18 Distance Model with "Radiobuilder" year—25. Laboratories, 151-A Liberty, San Francisco.</p>
<p><b>MISCELLANEOUS</b></p>	<p><b>SHORT WAVE LISTENERS' QSLs</b> Cards. Reply getters, Samples (Stamps). W-8-E-8-N, 1827 Cote, Toledo, Ohio.</p>	<p><b>BUY YOUR RECEIVER ON HINDS!</b> "Easy Payment" Plan. Write Hinds &amp; Edgerton, 19 S. Wells St., Chicago, Illinois.</p>
<p><b>OHM'S LAW CALCULATOR—</b> Lightning Slide Rule; solves all problems of Voltage, Current and Resist-</p>	<p><b>QSL SWL CARDS, NEAT, AT-</b> tractive, reasonably priced, samples free. Miller, Printer, Ambler, Pa.</p>	<p><b>TELEVISION</b></p> <p><b>TELEVISIONS, KITS \$4.00, \$6.00, \$15.00.</b> Years of experience. Arthur Pohl, 2131 Palma, Detroit, Mich.</p>

Some of the most successful radio supply houses and parts manufacturers started with a two or three line advertisement in the Classified Section. Anything that can be used by over a quarter of a million readers can be advertised profitably. Now that nearly two billion dollars of bonus money have been distributed among three and a half million men, money will be circulated more freely. The best buying months are just ahead of you. Take advantage of your opportunity.

**THE ONE AND ONLY**  
*Encyclopedia on Short Waves*  
 By C. R. Leutz and R. B. Gable

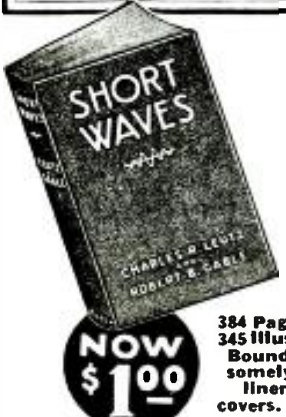

"SHORT WAVES" is written by Leutz and Gable, two foremost Radio authorities. You will remember Charles R. Leutz as one of the pioneers in radio, also designer and manufacturer of the famous LEUTZ Transoceanic Receivers. Mr. Robert Gable owned and operated one of the finest low power broadcasting stations in the country. He is well known as an experimenter and research worker in scientific fields. Considering the value of this book for data alone, its cost should really be more than originally asked. But when you see the illustrations in the book you will marvel at how this book could be sold for ONE DOLLAR. It originally sold for \$2.98. The book is printed on a very expensive super-calendered paper. It contains 384 pages with over 315 photographic illustrations and diagrams. The supply of these books is not expected to last long. Once they are gone no additional copies will be available. ORDER NOW—be sure to tell your friends about this remarkable book value. Send the coupon today for your copy of "SHORT WAVES" by Leutz and Gable.

**YOU SAVE \$1.98 JUST AS LONG AS THE SUPPLY OF THIS BOOK LASTS! THIS BOOK ORIGINALLY SOLD FOR \$2.98**

"SHORT WAVES" is the most important and comprehensive volume of short-waves ever published. This book has EVERYTHING on short-waves—it literally contains a complete education on short-waves.

• Partial Contents of "Short Waves" •

HISTORICAL REVIEW  
 SHORT WAVE PROPAGATION  
 COMMERCIAL RADIO TELEPHONY AND TELEGRAPHY  
 SHIP TO SHORE RADIO TELEPHONY  
 DIRECTIONAL ANTENNAE  
 TELEVISION  
 AIRCRAFT RADIO EQUIPMENT  
 SHORT WAVE BROADCAST RECEIVERS  
 ULTRA SHORT WAVES (Medical and Surgical Applications)  
 AMATEUR SHORT-WAVE EQUIPMENT

Don't forget that this comprehensive volume is sold on a MONEY-BACK GUARANTEE. If you are not satisfied with it, return it within three days for refund. Use the coupon at the left for ordering your copy of "SHORT WAVES" by Leutz and Gable.

**RADIO PUBLICATIONS**  
 103 Hudson St. New York, N. Y.

**MAIL COUPON TODAY!**

RADIO PUBLICATIONS, Dept. SWC-8-36  
 103 Hudson Street, New York, N. Y.

Enclosed you will find my remittance of One Dollar (\$1) cash, money order or new U. S. stamps for which send me One copy of "SHORT WAVES" by Leutz and Gable. I understand this book may be returned to you within three days if I am not completely satisfied and my money refunded.

NAME \_\_\_\_\_  
 ADDRESS \_\_\_\_\_  
 CITY \_\_\_\_\_ STATE \_\_\_\_\_  
 (include 15c extra to cover mailing charges) (25c foreign countries)

Please mention SHORT WAVE CRAFT when writing advertisers

### Hudson Four Tube AC-DC Radio

Tubes 1/38, 1/76, 1/6C6, 1/6D6



ILLUMINATED AIR-PLANE DIAL. Auto-cycle calibration. Tunes from 510 to 1750 K.C. (170-575 Meters) complete with 1 tube, less short wave and long wave bands and switch. Phonograph \$6.95

EXTRA—Short Wave band and switch 2-300-6,500 K.C. (46-130 Meters) add letter S to above models \$1.00  
 Long wave band and switch 150-375 K.C. (800-2,000 Meters) for use abroad only, add letter E to above \$1.25  
 Phonograph Jacks \$1.00

### CONTINENTAL 5-TUBE AUTO RADIO

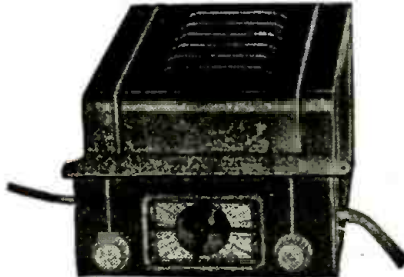

This is the finest 5-tube set ever offered. Regular price \$16.95  
 Special \$29.95

Complete with 5 tubes, ready to use. Nothing else to buy.  
 5-tube superheterodyne circuit—very selective, extra sensitive, marvelous tone. Can be installed in 15 minutes in any car. No suppressors required.

### FOR YOUR VACATION WRIGHT-DE COSTER 7-TUBE FARM BATTERY RADIO

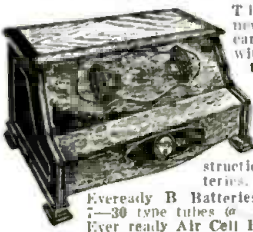

These radios, brand new, in sealed factory cartons, will operate with 99 or 30 type of tubes. Requires 3-4 1/2 B's and one (1) Air cell battery only. Limited number at this price. Complete with full instructions, less halogen tubes \$4.95

### AC-DC Filter Chokes

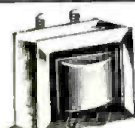

Small, compact units designed for use in AC-DC midget sets. Will pass 60 mls. Available in sizes from 200 to 500 ohms. No. AD-110 25c

### SPECIAL OFFER

DILCO R. C. A. Licensed 100% Triple Tested TUBES YOUR CHOICE ONLY \$1.00 ANY GROUP

Quan.	Type	Quan.	Type
3	50	5	21A
2	12A7	4	35-51
3	2A3	4	36
12	27	4	47
6	26	4	82
6	01A	4	6D6
6	12A	4	5Z3
4	30	6	20
4	31	4	33
6	71A	6	36
6	56	4	1A6
2	10	3	484

866 RECTIFIERS 89c

### GENUINE CONDENSER CORP. OF AMERICA ELECTROLYTIC CONDENSERS

WET		Tubular Condenser	
500 Volts		All Sizes—400-600 Volts	
4 MFD 15c		1 doz. 4c ea.	
6 MFD 20c		1 doz. 10c ea.	
8 MFD 23c		1 doz. 15c ea.	
10 MFD 30c		1 doz. 25c ea.	
12 MFD 35c		1 doz. 35c ea.	
14 MFD 40c		1 doz. 45c ea.	
16 MFD 45c		1 doz. 55c ea.	

### Hum Free Power Supply Pack

This pack will supply 6.3 or 2.5 filament voltage. Pure Rectified D.C. 350 volts at 80 MILS 6 AMP'S for Filament.



### Complete Kit \$2.49

with wiring diagram and drilled chassis less tube, unwired. Wiring 50c extra AD-201 80-Rectifier tube extra 34c. Shipping weight, 12 lbs.

### Three-Gang Midget Tuning Condenser

Capacity .000365 mf. Measure 3/4"x1/2" shaft. With compensating condenser. No. AD-113 YOUR PRICE 69c

### Four-Gang Tuning Condenser

Capacity .000365 per section. Solid brass plates. Ship. wt. 5 lbs. No. AD-115 YOUR PRICE 20c

### Midget Variable Condensers

Excellent for use as antenna trimmers in short-wave sets and as variable tuning condensers. Capacity approximately 20 mf. Sold complete with knob and pointer. Single hole mounting. 3 solid brass plates. Ship. wt. 1/2 lb. No. AD-117 YOUR PRICE 25c

### FREE 64-page catalog and treatise. Send stamp for our FREE treatise and catalog which contains much valuable data and radio information. There is no obligation involved. Absolutely free. Book sent by return mail.

### R. C. A. Phonograph Motor

This is the same sturdy motor used in the highest quality phonographs and combinations made by R. C. A. Victor. List Price \$18.50 complete with turntable. Designed for 110-120 volts, A.C. and available for either 25 or 60 cycles (please specify which when ordering.) For 78 RPM records. Ship. wt. 10 lbs. No. AD-106 YOUR PRICE \$3.95 LIMITED QUANTITY

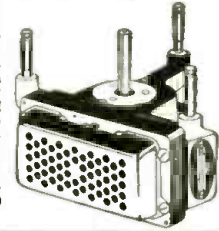

### Yaxley Band-Changing Switch

Designed especially for all-wave sets. Heavy silver plated contacts. Consists of six 2-gang decks—12 gangs in all. Four positions. Excellent for short-wave as well as for analyzers. List price \$4.32. Never before offered at the low price shown below. Ship. wt., 1 lb. No. AD-111 29c

### BANDSPREAD VARIABLE CONDENSERS

Available with 11 plates, (approx. .00025 mf); 13 plates, (.0003 mf); 17 plates, (.000365 mf); 23 plates, (.0005 mf); 16 plates, (.001 mf). For short-wave bandspread receivers as well as for standard broadcast and long-wave receivers. Ship. wt., 2 lbs. No. AD-116 Variable Condensers—each 25c

### G. E. POWER TRANSFORMER

Manufactured by General Electric. A well designed transformer. Has 6.3 volt filament winding. Designed for 110-125 volts, 50-60 c. A.C. Specifications: 6.3 V., 2 1/2 amp.; 7 V., 2 amp.; for fil. of 80 tube; 750 V., C.T., 75 mls. for plate output. Ship. wt., 5 lbs.; also available in 2 1/2 V. No. AD-101, 6 to 7 tube transformer, 75 mls. 99c  
 No. AD-102, 7 to 8 tube transformer, 100 mls. \$1.49  
 No. AD-103, 8 to 10 tube transformer, 125 mls. \$1.96

### R. M. A. Color Coded Carbon Resistors

These are all Brand New Stock. 100 Assorted sizes, 50 ohms—5 meg ohms, 1/4, 1/2 watt sizes guaranteed 10% accuracy resistors. Complete assortment, 100 resistors \$1.50 Individual sizes, 2c each. AD 185—shipping weight 4 lbs.

### Unshielded Power Transformers

6-8 Tube 6.3 volts. These transformers, the products of one of America's largest radio factories, are brand new, 6-tube, 6.3 filament, 280 filament, 2 volt, 750 volt, C.T. high, color code diagram with each one; ideal for replacement or for new sets. AD-201 6-tube unshielded transformers \$0.65  
 AD-202 8-tube unshielded transformers .85  
 AD-203 10-tube unshielded transformers 1.15

### UNIVERSAL UTILITY MOTOR

These motors will operate on 110-125 Volts AC or DC. Can be used for toy trains, aquarium pumps, window displays, oscillograph, Television, etc. Not a toy, can be put to many uses. Shipping weight, 8 lbs. AD 563—Utility motor \$1.39



2 1/2 MH. SHORT WAVE R. F. CHOKE. These low loss chokes are wound on Isolantite forms are used in every S. W. Set. Special Pie Wound Chokes AD-301 15c

### AC-DC LINE CORD RESISTORS

In the following sizes 13, 150, 160, 180, 200, 250, 300, 350-500 ohm. Line Cord Resistors AD 303 25c



Complete parts in stock for all diagrams appearing in Short Wave Craft, Radio Craft, QST, Popular Mechanics, etc.

# UNITED RADIO COMPANY

Successors to Radio Trading Company

58 MARKET STREET Dept. S-7 NEWARK, N. J.

### Short Wave Scout News

(Continued from page 220)

month. (All E.S.T.)  
 YVR—9.14 meg. Heard broadcasting one evening at 7:30 to 8:30 p.m. Very good.  
 FVA—8.96 meg. Heard telephoning Paris at 2:25 a.m., April 26th. Fair.  
 SUZ—13.83 meg. Heard 1:45 to 2:10 p.m., on April 27th. Call London. Very good.  
 IDU—13.38 meg. Calling Italy on April 26th at 2:40 p.m. Poor.  
 HP5K—6.05 meg. Broadcasting on April 28th at 5:00 to 6:00 p.m. Good signal.  
 CB960—9.60 meg. Broadcasting on April 29th at 7:00 to 8:30 p.m. Good.

RKI—15.04 meg. Broadcasting on April 30th at 2:00 a.m. Fair.  
 W2XGB—6.42 meg. Broadcasting on April 27th at 8:00 to 10:00 p.m. Very good.  
 WCT—13.40 meg. Calling WNC May 1st at 3:30 p.m. Good.  
 H17P—6.80 meg. Broadcasting May 2nd 9:30 to 10:00 p.m. Good.  
 LRX—9.59 meg. Broadcasting May 3rd 10:00 to 11:00 p.m. Very good.  
 YNLF—6.45 meg. New wave. Heard on May 5th at 6:30 to 7:00 p.m. Fair.  
 Veris received—YNLF and W9XAA 25 meters; PHI 25 meters. VPD, SUZ and OAX4D.  
 WM. C. PALMER,  
 7210 Ridge Rd.,  
 Parma, Ohio.

### New "Ham" Apparatus

(Continued from page 217)

● A NEW line of stand-off insulators has recently been released for the amateur and experimenter and five different sizes are shown in the photograph. One measures 2 3/4" high and has a base of 1 1/4". This is the largest one and has a screw-thread at each end. The next is 1 9/16" high and is provided with a jack for a standard banana type plug. Another smaller one, identical to it is 1" high and has a jack. The next is like the 1" insulator, except that it is tapped at both ends for an 8-32 screw. The smallest measures 5/8" and is tapped at either end for a 6-32 screw.

Please mention SHORT WAVE CRAFT when writing advertisers

● Index to Advertisers ●

<b>A</b>	
Ace Radio Laboratories.....	244
Aerovox Corporation.....	233
Allied Engineering Institute.....	240
Allied Radio Corp.....	238
American Microphone Co.....	238
<b>B</b>	
Richer, H., & Company.....	245
Brush Development Co., The.....	243
Bud Radio, Inc.....	240
Burstein-Applebee Co.....	237
<b>C</b>	
Cameradio Co.....	237
Candler System Co.....	236
Cannon, C. F., Company.....	239
Centrallion Engineering Co.....	243
Chicago Radio Apparatus Co., Inc.....	239
Classified Advertisements.....	253
Cornell-Dubilier Corporation.....	233
Coyne Electrical & Radio School.....	193
<b>D</b>	
Dataprint Company.....	240
Dodge's Institute.....	236
<b>E</b>	
Eilen Radio Laboratories.....	231
Electrad, Inc.....	238
Everyday Science & Mechanics.....	242
<b>F</b>	
First National Television, Inc.....	236
<b>G</b>	
General Cement Mfg. Co.....	240
General Engineering Corp.....	240
G. F. Sign Co.....	232
Goldentone Radio Co.....	243
Gold Shield Products Co.....	242, 244, 255
Guy Stokely Radio Corp.....	229
<b>H</b>	
Hallcrafters, Inc.....	230
Hammarlund Manufacturing Co., Inc.....	233
Harrison Radio Company.....	230
<b>I</b>	
Instructograph Company.....	236
Insuline Corp. of America.....	238
<b>J</b>	
Jobs & Careers.....	245
<b>K</b>	
Korrol Mfg. Co., Inc.....	238
<b>L</b>	
Lancaster, Allwin & Rommel.....	232
Lejay Manufacturing Co.....	240
<b>Mc</b>	
McElroy, T. R.....	236
<b>M</b>	
M. & H. Sporting Goods Co.....	235
Marine Radio Company.....	232
Midwest Radio Corp.....	Inside Front Cover
<b>N</b>	
National Company, Inc.....	245
National Radio Institute.....	Back Cover
<b>O</b>	
Oxford-Tartak Radio Corp.....	243
<b>P</b>	
Polk, R. L., & Co.....	248
<b>R</b>	
Radio & Television Institute, Inc.....	236
Radio Constructors Laboratories.....	234, 235
Radio-Craft.....	244
Radio Handbook, The.....	247
Radio Publications.....	248, 249, 250
Radio Training Assn. of America.....	236
RCA Institutes, Inc.....	236
RCA Manufacturing Co., Inc.....	217
<b>S</b>	
Sargent, E. M., Co.....	239
Short Wave Coil Book.....	244
Short Wave League.....	238, 240, 252
Short Wave Manuals.....	242
Short Waves.....	253
<b>T</b>	
Teleplex Co.....	255
Triplett Electrical Instrument Co.....	230
Tri-State College.....	236
Try-Mo Radio Co., Inc.....	242
<b>U</b>	
Ultra High Frequency Products Company.....	237
Uncle Dave's Radio Shack.....	230
United Radio Company.....	254
Universal Microphone Co. Ltd.....	235
<b>W</b>	
Wellworth Trading Company.....	248, 251
Wholesale Radio Service Co., Inc.....	241
Woman's Digest.....	242
Wright-DeCoster, Inc.....	251
<b>X</b>	
X.L. Radio Laboratories.....	239

(While every precaution is taken to insure accuracy, we cannot guarantee against the possibility of an occasional change or omission in the preparation of this index.)

Short Waves Linked Mine Rescue Scene With Press

● THE press reports which commanded the attention of the whole world for nearly two weeks, during the heroic rescue work carried on at the scene of the Moose River gold mine in Nova Scotia, were carried to a great extent by an amateur short-wave link between the mine and Halifax.

There was only one telephone line connecting the scene of the Moose River mine, and press communications were in a bad way until the Canadian press awakened to the fact that amateur radio men, with their short-wave sets, might bridge the gap and they did.

Local members of the Halifax Amateur Radio Club, which is associated with the American Radio Relay League, stepped into the picture by establishing a low-power battery-operated transmitter at Moose River, manned by a small group of amateurs under the leadership of Mr. Arthur Crowell, the Section Communication Manager of ARRL.

In Halifax at the home of Mr. Clifford Short, a receiving and relay transmitting station, connected through with the office of the Canadian Press, was established with another group of amateurs who



Where short-wave messages from the mine-rescue scene were picked up and put on the "press" wires.

worked in relays. During the whole time these short-wave amateur operators hardly knew what sleep meant. Owing to the range of the low-power sets used at Moose River, these boys had to find ways and means of keeping the communication uninterrupted, as newspapers were becoming interested all over the continent; and to overcome the interference with the 80-meter band, particularly at night, from other amateur stations in different parts of the continent, they established an intermediate relay station at the small village known as Musquodoboit, which is located about 50 miles from Halifax.

Practically every word published by Canadian Press in the Canadian newspapers and their affiliations in the United States, was handled by a network of amateur short-wave telegraph stations. So successful was this "amateur network" that it was not long before professional apparatus and operators were established at the mine, to give a similar service to other Press Associations. Individual correspondents of newspapers of course were sending out their own stories over the one reliable telephone circuit, and after the first two days a short-wave transmitter was established for the British United Press. The "amateurs" with their hastily assembled equipment, worked along side of professional short-wave operators sending out "news" and stayed on the job, not only until the men were rescued, but many hours afterwards, until the full details of the rescue could be transmitted to the press everywhere.

When the Canadian Radio Commission established the National network, VE9HX (short-wave station) carried the same broadcast as CHNS (the broadcast station, on 930 kc.).

At Last! The Perfect  
**CODE TEACHER!**  
NEW MASTER TELEPLEX

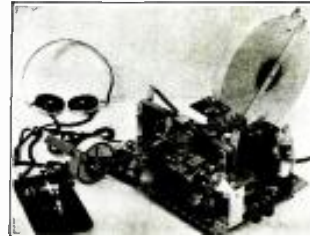

For beginners, experienced operators, a n d schoolroom. The sure easy way to learn code and to step up your speed. This amazing new instrument will record your own sending on double row perforated paper and repeat it back to you at any speed you desire. Thousands of words can be recorded on one tape.

**NO BATTERIES  
NO WINDING  
ALL ELECTRIC**

It is the same in principle, and in operation is equal to the Wheatstone Perforator and Transmitter, which cost over \$1,000.

**BUY IT OR RENT IT**  
Send for Folder S8 which tells you how to get the use of this instrument without buying it. No obligation. We furnish complete course and personal instruction with a money-back guarantee. Low cost, easy terms. Write today for information.

**"HAM" SPECIAL** Standard Teleplex A highly efficient code teacher using heavy specially prepared waxed paper tape, having two rows of perforations. Write for Free folder S.W.

We are the originators of this type instrument.  
**TELEPLEX CO.**  
72 Cortlandt St. New York City  
The New Master Teleplex "The Choice of Those Who Know"

**VEST POCKET SOLDERING IRON**



Smallest good iron now on the market. Will do the work of

irons twice its size. Only 11 inches long. 1/2 inch in diameter. By using the highest grade elements, it heats up in half the time of ordinary irons. Guaranteed to give satisfaction or money back.

Sent Prepaid for.....\$1.00  
Gold Shield Products Co., 17 West 60th St., N. Y. City

**NO ONE READS AND THEN DISCARDS**  
**SHORT WAVE CRAFT**



Readers keep their copies for years as a steady reference and thousands of letters attest to this.

It is now possible to save your copies and for this purpose we designed a splendid binder for you which holds twelve copies. It is made of heavy substantial material and is covered with black grain leatherette. The name of the magazine is stamped in gold on the cover.

An ingenious mechanical arrangement is provided which makes it possible to hold the copies flat when reading from the binder.

SHORT WAVE CRAFT Binder as described, prepaid in the United States \$1.25

Canada and foreign countries 25c extra. We accept money order, check, stamps or cash.

**SHORT WAVE CRAFT**

99-101 HUDSON ST., NEW YORK, N. Y.

Please mention SHORT WAVE CRAFT when writing advertisers

# Here are the Six BEST SHORT-WAVE RADIO BOOKS!

Without doubt you will have to go a long way to buy better books on short waves than you find on this page. Each book is written by a well-known authority on short waves . . . each book has been carefully illustrated with photographs and diagrams to

make the study of this field of radio much simpler. The volumes on this page are the finest books on short-waves which are published anywhere today. Order one or more copies today . . . find out for yourself how fine they are. Prices are postpaid.

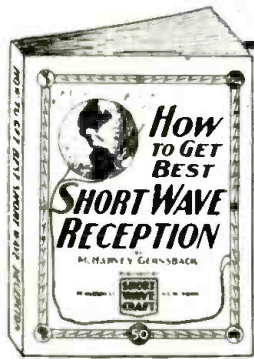

## How to Get Best Short-Wave Reception

By M. HARVEY GERNSBACK

This book tells you everything you ever wanted to know about short-wave reception. The author, a professional radio listener and radio fan for many years, gives you his long experience in radio reception and all that goes with it.

Why is one radio listener enabled to pull in stations from all over the globe, even small 100-watt, 10,000 mile away, and why is it that the next fellow, with a much better and more expensive equipment, can only pull in the powerful stations that any child can get without much ado?

- The reason is intimate knowledge of short waves and how they behave. Here are the chapters of this new book:
1. What are Short Waves and what can the listener hear on a short-wave receiver or converter?
  2. How to tune and when to listen in on the short wave.
  3. How to identify short-wave stations.
  4. Seasonal changes in short-wave reception.
  5. Types of receivers for short-wave reception.
  6. Aerial systems for short-wave receivers.
  7. Verifications from short-wave stations.

The book makes excellent reading matter. There are many tricks in short-wave reception that even some of the "old-timers" do not know. Be sure to get it.

40 Illustrations, 72 Pages. Stiff, flexible covers

50c

## HOW TO BUILD AND OPERATE SHORT-WAVE RECEIVERS

THIS is the best and most up-to-date book on the subject. It is edited and prepared by the editors of SHORT WAVE CRAFT, and contains a wealth of material on the building and operation, not only of typical short-wave receivers, but short-wave converters as well. Dozens of short-wave sets are found in this book, which contains hundreds of illustrations; actual photographs of sets built, hookups and diagrams galore.

This book is sold only at a ridiculously low price because it is our aim to put this valuable work into the hands of every short-wave enthusiast.

We know that if you are at all interested in short wave you will not wish to do without this book. It is a most important and timely radio publication.

150 Illustrations, 72 Pages. Stiff, flexible covers

50c

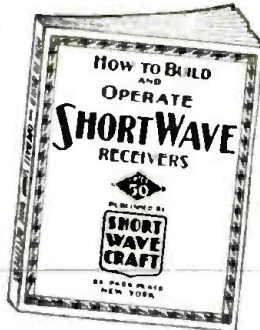

## THE SHORT-WAVE BEGINNER'S BOOK

HERE is a book that solves your short wave problems—leading you in easy stages from the simplest fundamentals to the present state of the art as it is known today. It is the only low priced reference book on short waves for the beginner. The book is profusely illustrated—it is not "technical." It has no mathematics and no technical jargon. It also gives you a tremendous amount of important information, such as time conversion tables, all about aerials, noise elimination, all about radio tubes, data on coil windings and other subjects.

### Partial List of Contents

- Getting Started in Short Waves—the fundamentals of electricity. Symbols, the Short Hand of Radio—how to read schematic diagrams. Short Wave Coils—various types and kinds in making them.
- Short Wave Aerials—the points that determine a good aerial from an inefficient one.
- The Transposed Lead-in for reducing Static.
- The Beginner's Short-Wave Receiver—a simple one tube set that anyone can build.
- How to Tune the Short-Wave Set—telling the important points to get good results.
- Audio Amplifiers for S-W Receivers.
- Learning the Code—for greater enjoyment with the S-W set. Wave length to Kilocycle Chart.
- Wire Chart—to assist in the construction of coils.

75 Illustrations, 40 Pages. Stiff, flexible covers

25c

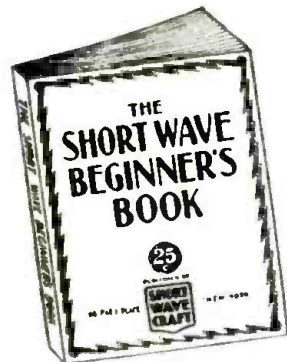

## 101 SHORT-WAVE HOOKUPS

Compiled by the Editors of SHORT WAVE CRAFT

Each and every hook-up and diagram illustrated is also accompanied by a thorough explanation of what the particular hook-up accomplishes, what parts are required, and wiring information, values of resistors, etc., in fact, everything you want to know in order to build the set or to hook up the data required.

To be sure, all of the important sets which have appeared in print during the past five years are in this valuable book. Sets such as the Doerle's Dimension, the "Hi-Tone" Super, the-Hilodyne, Denton "Stand-By," Megadyne Triplet 2, "Fluke-Crotter," 2-Tube Superhet, Mindyne, "Loop" Receiver, "Doerle" 2-tube Battery, "Doerle" 3-tube Battery, "Doerle" 2-tube A.C. "Doerle" 3-tube A.C. "Doerle" Signal Gripper, Duo R.F. 4-tube Receiver, The Sargent 9-35 Tapped Coil Receiver, Globe-Glider 7, The 2-Tube "Champ"—2 Tubes, Equal 3, Ham-Band "2-Tube, Fee-Wee" Worth All-Way 6, Denton Economy 3, 2-Tube "Regenerative-Hilodyne" will be found here, with full descriptions. In many cases, we have also included a picture hook-up for those who do not wish to follow the regular symbolic hook-up, but wish to have a regular wiring diagram. This is a very handy volume, especially for those "lads" who wish to study the best sets in the short-wave art, from one tube up to ten tubes.

100 Illustrations, 72 Pages, 50c Stiff, flexible covers

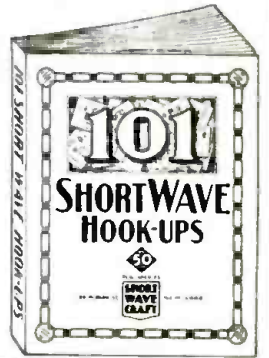

## HOW TO BECOME AN AMATEUR RADIO OPERATOR

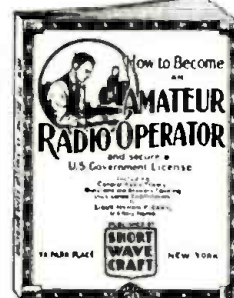

WE chose Lieut. Myron F. Eddy to write this book because of his experience in the amateur field has made him pre-eminent in this line. For many years he was instructor of radio telegraphy at the R.C.A. Institute. He is a member of the I.R.E. (Institute of Radio Engineers), also the Veteran Wireless Operators Association.

If you intend to become a licensed code operator, if you wish to take up phone work eventually—this is the book you must get.

### Partial List of Contents

Ways of learning the code. A system of sending and receiving with necessary drill words is supplied so that you may work with approved methods. Concise authoritative definitions of radio terms, units and laws, brief descriptions of commonly used pieces of radio equipment. This chapter gives the terminology of the radio operator. Graphic symbols are used to indicate the various parts of radio circuits. General radio theory particularly as it applies to the beginner. General electron theory is briefly given, then waves—their creation, circuits, particularly those used in radio are explained and typical basic circuits are analyzed. Descriptions of modern receivers that are being used with success by amateurs. You are told how to build and operate these sets. Amateur transmitters. Diagrams with applications are furnished so construction is made easy. Power equipment that may be used with transmitters and receivers, rectifiers, filters, batteries, etc. Regulations that apply to amateur operators. Appendix which contains the International "Q" signals, convenient for reference purposes, etc.

150 Illustrations, 72 Pages, Stiff, flexible covers

50c

## TEN MOST POPULAR SHORT-WAVE RECEIVERS

—HOW TO MAKE AND WORK THEM

THE editors of SHORT WAVE CRAFT have selected ten outstanding short-wave receivers and these are described in the new volume. Each receiver is fully illustrated with complete layout, pictorial representation, photographs of the set complete, hookup and all worth-while specifications. Everything from the simplest one-tube set to a 3-tube T. R. F. receiver is described. Complete lists of parts are given to make each set complete. You are shown how to operate the receiver to its maximum efficiency.

### CONTENTS

- The Doerle 2-Tube Receiver That Reaches the 12,500 Mile Mark, by Walter C. Doerle.
- The E. F. Pantone S-W Receiver having two stages of Tuned Radio Frequency, by Clifford E. Denton and H. W. Secor.
- My de Luxe S-W Receiver, by Edward G. Ingram.
- The Hinesweg 2-Tube 12,000 Mile DX Receiver, by A. Hinesweg, Jr.
- Build a Short-Wave Receiver in your "Brief-Case" by Hugo Gernsback and Clifford E. Denton.
- The Denton 2-Tube All-Wave Receiver, by Clifford E. Denton.
- The "Stand-By" Electrified.
- A COAT-POCKET Short-Wave Receiver, by Hugo Gernsback and Clifford E. Denton.
- The S-W PENTHETE-4, by H. G. Clain, M. E.
- Louis Martin's Idea of A GOOD S-W RECEIVER, by Louis Martin.

75 Illustrations, 40 Pages, 25c Stiff, flexible covers

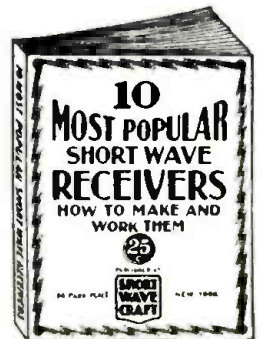

All the books shown on this page are published exclusively by

## SHORT WAVE CRAFT

99-101 Hudson Street, New York, N. Y.

CLIP-MAIL

SHORT WAVE CRAFT, 99-101 Hudson Street, New York, N. Y.

SW-8-36

Gentlemen: I enclose herewith my remittance for the amount of \$..... for which you are to send me, Postpaid, the books checked below.

- |   |   |
|---|---|
| <input type="checkbox"/> How to Get Best Short-Wave Reception..... 50c each         | <input type="checkbox"/> How to Become an Amateur Radio Operator..... 50c each                          |
| <input type="checkbox"/> 101 Short-Wave Hook-ups..... 50c each                      | <input type="checkbox"/> Ten Most Popular Short-Wave Receivers, How to Make and Work Them..... 25c each |
| <input type="checkbox"/> How to Build and Operate Short-Wave Receiver..... 50c each | <input type="checkbox"/> The Short Wave Beginner's Book..... 25c each                                   |

Name.....  
Address.....  
City..... State.....

(Send remittance in form of check or money order. If letter contains cash or unused U. S. Postage Stamps, register it.)

## OVERSEAS READERS!

These books can be obtained from the following houses:

- GREAT BRITAIN  
Gorrings's  
9a, Green Street, Leicester Square  
London, England
- FRANCE  
Editions Radio  
42 Rue Jacob  
Paris
- AUSTRALIA  
McGill's  
183-195, 218 Elizabeth St.  
Melbourne, C. I.

Please mention SHORT WAVE CRAFT when writing advertisers



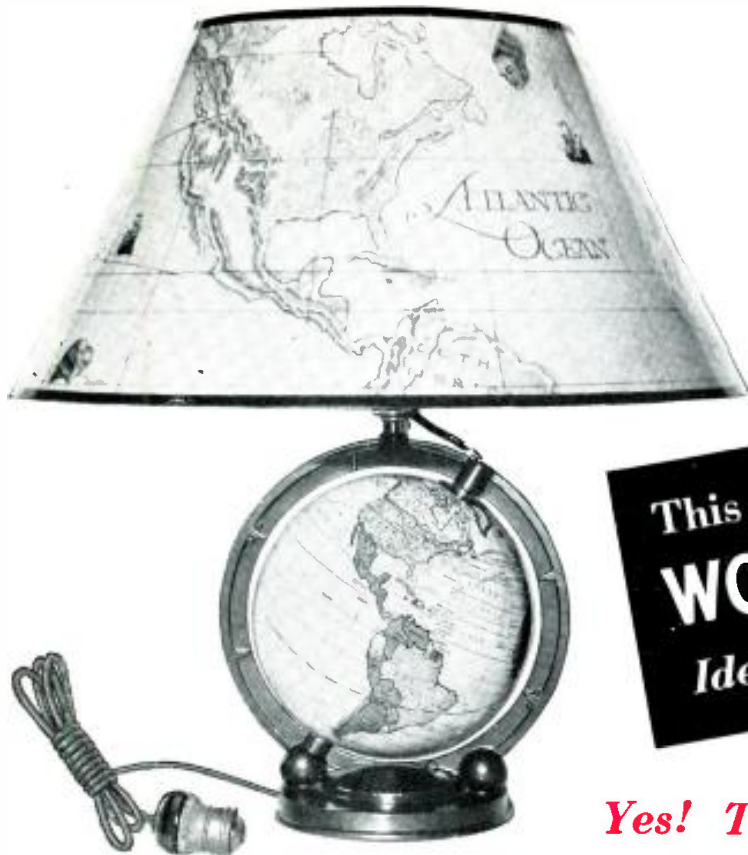

*Free!*

This useful and ornamental  
**WORLD-GLOBE LAMP**  
 Ideal for short wave fans

*Yes! The globe revolves!*

**N**EVER in the six years that SHORT WAVE CRAFT has been published, have we found *anything* that is as *useful* and *ornamental* as the WORLD-GLOBE LAMP we now offer free to our readers.

This beautiful WORLD-GLOBE LAMP measures 17½" high. The attractively colored shade, with nautical and map designs, is 8" in height and 16" in diameter. It is made of fine quality parchment, highly glazed, to assure long life. A slightly damp cloth quickly removes dust from the shade. The 6¼" globe, printed in many colors, has a *full meridian*, and *rotates*. Hundreds of names—countries, cities, rivers, oceans and others are *clearly printed on the globe*.

Another feature on this WORLD-GLOBE LAMP is the *movable hour scale* found at the north pole. This permits determining the correct time in any part of the world.

The metal parts are finished in antique bronze. A piece of heavy green felt is glued under the base, therefore it may be placed *anywhere*, without fear of marring table, desk, etc.

The weight of the WORLD-GLOBE LAMP is nearly three pounds. When packed for shipping, six pounds.

Here is the way to get this beautiful prize. Fill in the coupon in the right hand corner—cut it out and mail it to us together with your remittance of \$2.50. You will receive a full year's subscription (12 months) to SHORT WAVE CRAFT—the *greatest short-wave magazine in the world today*. In addition, we will send you absolutely FREE one of these handsome WORLD-GLOBE LAMPS. *Old subscribers* may renew their subscription now for another year following expiration of their present one and still receive this WORLD-GLOBE LAMP.

Only a limited number of WORLD-GLOBE LAMPS are available. Take advantage of this offer *without delay* in order to insure receiving *your free gift*. RUSH THE COUPON TODAY.

**MAIL  
 COUPON  
 TODAY!**

**WHAT THEY SAY ABOUT THE WORLD-GLOBE LAMP!**

**Very Well Pleased**  
 Gentlemen:  
 I am very well pleased with my **Globe-Lamp**. It presents a handsome and novel appearance and is most appropriate when located near an all-wave radio set. When lighted at night, it sheds a warm, soft glow, and the parchment shade shows almost attractively. Unquestionably, the combination of the lamp and **SHORT WAVE CRAFT** for \$2.50 is a real bargain.  
 William E. Sloan, Jr.,  
 67 Exchange Street,  
 Rochester, New York.

**Unique, Beautiful and Useful**  
 Gentlemen:  
 The **Globe-Lamp** arrived today, also the magazine. Congratulations on a premium so unique, beautiful and, above all, useful, especially to DXers on the short-wave bands. I already have a large globe, but I expect to use the small one much more frequently and with equal satisfaction. It goes fine with the new Hammerlund "Super Pro."  
 T. H. Warnock,  
 99 Elm Street,  
 Meriden, Connecticut.

**Wouldn't Take \$15.00 For It**  
 Gentlemen:  
 I received the **Globe-Lamp** and I am very much pleased with it. I think it is handsome and think a good deal of it. I wouldn't take \$15.00 for it. The lamp sets on top of the radio and is handy to glance at when I hear the foreign stations.  
 Warren G. Ryder,  
 Barnstable Radio Shop,  
 Barnstable, Mass.  
 P.S.: Many thanks for the lamp!

**SHORT WAVE CRAFT** SWC-836  
 99 Hudson Street, New York, N. Y.

Gentlemen: Enclosed you will find my remittance of \$2.50 (plus \_\_\_\_\_ cents shipping charges) for which enter my subscription for **SHORT WAVE CRAFT** for one year (12 issues). This amount entitles me to a **WORLD-GLOBE LAMP** free. See chart next to coupon for shipping charges on **WORLD-GLOBE LAMP**.

( ) Enclosed find my remittance of \$2.50, please send me the **WORLD-GLOBE LAMP** by express collect.

Name .....

Address .....

City ..... State .....

Send remittance in form of check or money order—register letter if it contains cash or unused U. S. postage stamps.

**How to Order Your WORLD-GLOBE LAMP**

Simply fill in the coupon at the right and mail together with check or money order. Register letter if cash or coin is sent. To cover shipping charges on **WORLD-GLOBE LAMP**, add to your remittance the amount indicated. If you are located: East of the Mississippi add 35 cents; between the Mississippi and the West Coast add 70¢; Foreign Countries add \$1.30. Any excess remittance will be refunded.

**SHORT WAVE CRAFT**

99 HUDSON STREET

NEW YORK, N. Y.

# Read what happened



**YES!**

I'll take your training. That's what S. J. Ebert said. He has made good money and found success in Radio.

to these  
two men

when I said:



**NO!**

I'm not interested. That's what this fellow said. Today he would be ashamed if I gave you his real name.

## I will Train You at Home in Spare Time for a GOOD JOB IN RADIO

These two fellows had the same chance. They each clipped and sent me a coupon, like the one in this ad. They got my book on Radio's opportunities.

S. J. Ebert, 104-B Quadrangle, University of Iowa, Iowa City, Iowa, saw that Radio offered him a real chance. He enrolled. The other fellow, whom we will call John Doe, wrote that he wasn't interested. He was just one of those fellows who wants a better job and better pay, but never does anything about it. One of the many who spend their lives in a low-pay, no-future job, because they haven't the ambition, the determination, the action it takes to succeed.

But read what S. J. Ebert wrote me and remember that John Doe had the same chance: "Upon graduation I accepted a job as serviceman, and within three weeks was made Service Manager. This job paid me \$40 to \$50 a week compared with \$18 I earned in a shoe factory before. Eight months later I went with Station KWCR as operator. From there I went to KTNT. Now I am Radio Engineer with WSUI. I certainly recommend the N.R.I. to all interested in the greatest field of all, Radio."

**Get ready for Jobs like these. Many Radio Experts make \$30, \$50, \$75 a week**

Spare time and full time set servicing; installing, operating, maintaining broadcast, aviation, commercial, police, ship and television stations. Opportunities with Radio dealers and jobbers. A service shop or re-

**Get my FREE LESSON on Radio Servicing Tips**

I'll prove that my training is practical, money-making information, that it is easy to understand—that it is just what you need to master Radio. My sample lesson text, "Radio Receiver Troubles—their Cause and Remedy" covers



a long list of Radio receiver troubles in A.C., D.C., battery, universal, auto, T.R.F., super-heterodyne, all-wave and other types of sets. And a cross-reference system shows you the probable cause and a quick way to locate and remedy these set troubles. A special section is devoted to receiver check-up, alignment, balancing, neutralizing and testing. Get this lesson Free. No obligation. Just mail coupon



"I want to help you. If you are earning less than \$35 a week I believe I can raise your pay. However, I will let you decide that. Let me show you what I have done for others, what I am prepared to do for you. Get my book, read it over, and decide one way or another." J. E. Smith.

tail Radio business of your own. I'll train you for these and other good jobs in connection with the manufacture, sale and service of Radio sending and receiving sets, auto Radios, loud speaker systems, short wave sets, etc.

**Save Money—Learn at Home, Money Back Agreement Protects You**

Hold your job. I'll train you quickly and inexpensively right at home in your spare time to be a Radio Expert. You don't need a high school or college education. My 50-50 method of training—half with lessons, half with Radio equipment—gives you broad practical experience—makes learning at home easy, fascinating, practical. I will

agree in writing to refund your money if you are not satisfied with my Lessons and Instruction Service when you graduate.

**Many Earn \$5, \$10, \$15 a Week in Spare Time While Learning**

That's what many of my students earn in spare time while taking my Course. I send you Extra Money Job Sheets containing tested plans and ideas to help you do it. Many students have made \$200 to \$1,000 in spare time while learning. Nearly every neighborhood offers a spare time serviceman an opportunity to make good money. I'll show you how to "cash in"—show you why my Course is famous as "the Course that pays for itself."

**Find Out What Radio Offers You**

Mail the coupon. My book is free to any ambitious fellow over sixteen years of age. It tells you about Radio's spare time and full time opportunities—about my Course, what I give you, what my students and graduates do and earn. There is no obligation. Act today. Mail coupon in an envelope or paste on a 1c postal card. Do it right now.

**J. E. SMITH, President  
National Radio Institute, Dept. 6HB3  
Washington, D. C.**



**FOR FREE BOOK OF FACTS ABOUT RADIO**

**J. E. SMITH, President, Dept. 6HB3  
National Radio Institute, Washington, D. C.**

Dear Mr. Smith: Without obligation, send me the Sample Lesson and your free book about spare time and full time Radio opportunities, and how I can train for them at home in spare time. (Please write plainly.)

NAME ..... AGE .....

ADDRESS .....

CITY ..... STATE ..... 14X1

**IF YOU DO NOT WANT TO CUT THIS COVER—SIMPLY WRITE US ON A POST CARD**